

Service Manual



TDS6000 Series Digital Storage Oscilloscope 071-7021-01

This document applies to firmware version 1.00 and above.

Warning

The servicing instructions are for use by qualified personnel only. To avoid personal injury, do not perform any servicing unless you are qualified to do so. Refer to all safety summaries prior to performing service.

www.tektronix.com

Copyright © Tektronix, Inc. All rights reserved.

Tektronix products are covered by U.S. and foreign patents, issued and pending. Information in this publication supercedes that in all previously published material. Specifications and price change privileges reserved.

Tektronix, Inc., P.O. Box 500, Beaverton, OR 97077

TEKTRONIX and TEK are registered trademarks of Tektronix, Inc.

WARRANTY

Tektronix warrants that the products that it manufactures and sells will be free from defects in materials and workmanship for a period of one (1) year from the date of shipment. If this product proves defective during its warranty period, Tektronix, at its option, will either repair the defective product without charge for parts and labor, or provide a replacement in exchange for the defective product.

This warranty applies only to products returned to the designated Tektronix depot or the Tektronix authorized representative from which the product was originally purchased. For products returned to other locations, Customer will be assessed an applicable service charge. The preceding limitation shall not apply within the European Economic Area, where products may be returned for warranty service to the nearest designated service depot regardless of the place of purchase.

In order to obtain service under this warranty, Customer must provide the applicable office of Tektronix or its authorized representative with notice of the defect before the expiration of the warranty period and make suitable arrangements for the performance of service. Customer shall be responsible for packaging and shipping the defective product to the service center designated by Tektronix or its representative, with shipping charges prepaid. Tektronix or its representative shall pay for the return of the product to Customer. Customer shall be responsible for paying any associated taxes or duties.

This warranty shall not apply to any defect, failure or damage caused by improper use or improper or inadequate maintenance and care. Tektronix shall not be obligated to furnish service under this warranty:

- a) to repair damage resulting from attempts by personnel other than Tektronix representatives to install, repair or service the product;
- b) to repair damage resulting from improper use or connection to incompatible equipment;
- c) to repair any damage or malfunction caused by the use of non-Tektronix supplies or consumables;
- d) to repair a product that has been modified or integrated with other products when the effect of such modification or integration increases the time or difficulty of servicing the product; or
- e) to repair damage or malfunction resulting from failure to perform user maintenance and cleaning at the frequency and as prescribed in the user manual (if applicable).

THE ABOVE WARRANTIES ARE GIVEN BY TEKTRONIX WITH RESPECT TO THIS PRODUCT IN LIEU OF ANY OTHER WARRANTIES, EXPRESS OR IMPLIED. TEKTRONIX AND ITS VENDORS DISCLAIM ANY IMPLIED WARRANTIES OF MERCHANTABILITY OR FITNESS FOR A PARTICULAR PURPOSE. TEKTRONIX' RESPONSIBILITY TO REPAIR OR REPLACE DEFECTIVE PRODUCTS IS THE SOLE AND EXCLUSIVE REMEDY PROVIDED TO THE CUSTOMER FOR BREACH OF THIS WARRANTY. TEKTRONIX AND ITS VENDORS WILL NOT BE LIABLE FOR ANY INDIRECT, SPECIAL, INCIDENTAL, OR CONSEQUENTIAL DAMAGES IRRESPECTIVE OF WHETHER TEKTRONIX OR THE VENDOR HAS ADVANCE NOTICE OF THE POSSIBILITY OF SUCH DAMAGES.

Table of Contents

List of Figures	v
List of Tables	viii
General Safety Summary	xi
Service Safety Summary	xiii
Preface	xv
Manual Structure	xv
Manual Conventions	xv
Related Documentation	xvi
Contacting Tektronix	xvi

Specifications

Product and Feature Description	1-1
Acquisition Features	1-2
Signal Processing Features	1-2
Display Features	1-2
Measurement Features	1-3
Trigger Features	1-3
Convenience Features	1-3
Specification Tables	1-4

Operating Information

Installation	2-1
Before You Start	2-1
Environmental Considerations	2-1
Connect the Peripherals	2-2
Power On the Instrument	2-4
Powering Off the Oscilloscope	2-5
Create an Emergency Startup Disk	2-5
Software Installation	2-6
Operating Information	2-7
Back Up User Files	2-7
User Interface Map	2-7
Front Panel Controls Map	2-9
Front Panel I/O Map	2-10
Instrument Diagnostics	2-10
Signal Path Compensation	2-11
Using the Online Help	2-11

Theory of Operation

Logic Conventions	3-1
Module Overviews	3-1
General	3-1
Input Signal Path	3-1
Display Panel	3-2
Front Panel	3-2
Rear Panel	3-3
Low Voltage Power Supply	3-3
Fans	3-3

Performance Verification

Conventions	4-2
Brief Procedures	4-5
Self Tests	4-5
Verify Internal Adjustment, Self Compensation, and Diagnostics	4-5
Functional Tests	4-6
Verify All Input Channels	4-7
Verify the Time Base	4-11
Verify the A (Main) and B (Delayed) Trigger Systems	4-13
Verify the File System	4-15
Performance Tests	4-17
Prerequisites	4-17
Equipment Required	4-18
TDS6000 Test Records	4-20
Signal Acquisition System Checks	4-29
Check DC Voltage Measurement Accuracy	4-29
Check Offset Accuracy	4-33
Check Maximum Input Voltage	4-37
Check Analog Bandwidth	4-41
Check Delay Between Channels	4-46
Check Channel Isolation (Crosstalk)	4-50
Check Input Impedance	4-54
Time Base System Checks	4-56
Check Long-Term Sample Rate and Delay Time Accuracy and Reference	4-56
Check Delta Time Measurement Accuracy	4-60
Trigger System Checks	4-63
Check Time Accuracy for Pulse, Glitch, Timeout, and Width Triggering	4-63
Check Sensitivity, Edge Trigger, DC Coupled	4-66
Output Signal Checks	4-72
Check Outputs — CH 3 Signal Out and Aux Trigger Out	4-72
Check Probe Compensation Output	4-75
Serial Trigger Checks (Option ST Only)	4-79
Check Serial Trigger Baud Rate Limits and Word Recognizer Position Accuracy	4-79
Check Serial Trigger Clock Recovery Range	4-86
Sine Wave Generator Leveling Procedure	4-90

Adjustment Procedure

Adjustment Procedures	5-1
Adjustment Interval	5-1
Adjustment After Repair	5-1

Maintenance

Preventing ESD	6-1
Inspection and Cleaning	6-2
General Care	6-2
Interior Cleaning	6-2
Exterior Cleaning	6-2
Removal and Installation Procedures	6-7
Preparation	6-7
Procedures for External Modules	6-9
Procedures for Modules	6-21
Troubleshooting	6-53
Service Level	6-53
Check for Common Problems	6-53
Equipment Required	6-55
Fault Isolation Procedure	6-55
PPC and NLX PC Diagnostics	6-60
Software Updates	6-63
After Repair	6-63
BIOS Error Messages (Bali NLX)	6-64
BIOS Error Messages (Radisys NLX)	6-65
BIOS Beep Codes (Bali NLX)	6-68
BIOS Beep Codes (Radisys NLX)	6-69
Dip Switch Controls	6-69
Diagnostic LED	6-70
Troubleshooting Using Reset Circuits	6-72
Installing the Processor Board Serial Number	6-74
Update/Restore the NLX Board CMOS	6-75
Installing an Authorization Key	6-75
Hard Disk Drive Maintenance	6-75
Repackaging Instructions	6-77
Packaging	6-77
Shipping to the Service Center	6-77

Options

Accessories	7-1
Options	7-3

**Electrical Parts List
Diagrams**

Symbols 9-1

Mechanical Parts List

Parts Ordering Information 10-1
 Module Servicing 10-1
Using the Replaceable Parts List 10-2
 Abbreviations 10-2
 Mfr. Code to Manufacturer Cross Index 10-2

List of Figures

Figure 2-1: Locations of peripheral connectors on rear panel	2-3
Figure 2-2: Line fuse and power cord connector locations, rear panel	2-4
Figure 2-3: On/Standby switch location	2-5
Figure 4-1: Toolbar and menu bar	4-3
Figure 4-2: Universal test hookup for functional tests - CH 1 shown	4-8
Figure 4-3: Universal test hookup for functional tests - CH 1 shown	4-9
Figure 4-4: Channel button location	4-9
Figure 4-5: Setup for time base test	4-11
Figure 4-6: Setup for trigger test	4-13
Figure 4-7: Setup for the file system test	4-15
Figure 4-8: Initial test hookup	4-30
Figure 4-9: Measurement of DC accuracy at maximum offset and position	4-32
Figure 4-10: Initial test hookup	4-34
Figure 4-11: Measurement of offset accuracy	4-36
Figure 4-12: Initial test hookup	4-38
Figure 4-13: Check of maximum input voltage	4-40
Figure 4-14: Initial test hookup	4-42
Figure 4-15: Measurement of analog bandwidth	4-44
Figure 4-16: Initial test hookup	4-47
Figure 4-17: Measurement of channel delay	4-48
Figure 4-18: Initial test hookup	4-50
Figure 4-19: Initial test hookup	4-54
Figure 4-20: Initial test hookup	4-56
Figure 4-21: Initial test hookup	4-57
Figure 4-22: Final test hookup	4-58
Figure 4-23: Delta time accuracy test hookup	4-60
Figure 4-24: Initial test hookup	4-64
Figure 4-25: Measurement of time accuracy for pulse and glitch triggering	4-65
Figure 4-26: Initial test hookup	4-67

Figure 4-27: Measurement of trigger sensitivity - 50 MHz results shown	4-69
Figure 4-28: Initial test hookup	4-72
Figure 4-29: Measurement of trigger out limits	4-74
Figure 4-30: Initial test hookup	4-75
Figure 4-31: Measurement of probe compensator frequency	4-76
Figure 4-32: Subsequent test hookup	4-77
Figure 4-33: Measurement of probe compensator amplitude	4-78
Figure 4-34: Initial test hookup	4-79
Figure 4-35: Isolated 0 triggering	4-81
Figure 4-36: Isolated 1 triggering	4-83
Figure 4-37: N modulo 3 triggering	4-85
Figure 4-38: Initial test hookup	4-86
Figure 4-39: Clock recovery	4-89
Figure 4-40: Sine wave generator leveling equipment setup	4-90
Figure 4-41: Equipment setup for maximum amplitude	4-92
Figure 6-1: Knob removal	6-9
Figure 6-2: Trim removal	6-11
Figure 6-3: Bottom cover removal	6-12
Figure 6-4: Cover removal	6-14
Figure 6-5: Cover removal	6-15
Figure 6-6: Line fuse and line cord removal	6-17
Figure 6-7: External modules	6-18
Figure 6-8: Internal modules	6-19
Figure 6-9: Front-panel assembly removal	6-22
Figure 6-10: J1 flex cable connector removal	6-23
Figure 6-11: Front panel board and keyboard removal	6-24
Figure 6-12: Display removal	6-26
Figure 6-13: Touch panel and LCD assembly removal	6-27
Figure 6-14: J4 cable clamp detail	6-28
Figure 6-15: Display adaptor board removal	6-28
Figure 6-16: Power flex circuit removal	6-30
Figure 6-17: Floppy disk drive removal	6-31
Figure 6-18: Hard disk drive removal	6-33
Figure 6-19: Removing the hard disk drive from the cartridge	6-33
Figure 6-20: CDRom-RW and bracket removal	6-35
Figure 6-21: Fan assembly removal	6-36

Figure 6-22: Front and rear power distribution and PA bus boards removal	6-38
Figure 6-23: Low-voltage power supply removal	6-39
Figure 6-24: NLX assembly removal	6-41
Figure 6-25: Riser adapter and NLX board removal	6-43
Figure 6-26: Microprocessor removal	6-45
Figure 6-27: PPC Processor board removal	6-47
Figure 6-28: Acquisition circuit board removal	6-50
Figure 6-29: Front panel combination assembly removal	6-51
Figure 6-30: TekConnect board and TekConnect bucket removal	6-52
Figure 6-31: Primary troubleshooting tree	6-56
Figure 6-32: Location of power-on and over current LEDs	6-57
Figure 6-33: Location of debug pins	6-58
Figure 6-34: Connectors J1 and J2	6-59
Figure 6-35: The three PCI busses	6-72
Figure 6-36: PCI and NLX video connectors	6-73
Figure 6-37: Location of jumpers and reset button	6-74
Figure 9-1: TDS7000 series block diagram	9-2
Figure 10-1: External parts	10-7
Figure 10-2: Front panel and drives	10-9
Figure 10-3: Power supply	10-11
Figure 10-4: Acquisition assembly	10-13
Figure 10-5: Accessories	10-14

List of Tables

Table 1-1: TDS6000 Series	1-1
Table 1-2: Channel input and vertical specifications	1-4
Table 1-3: Horizontal and acquisition system specifications	1-8
Table 1-4: Trigger specifications	1-9
Table 1-5: Serial Trigger specifications (Option ST Only)	1-13
Table 1-6: Display specifications	1-14
Table 1-7: Input/output port specifications	1-14
Table 1-8: Data storage specifications	1-16
Table 1-9: Power source specifications	1-16
Table 1-10: Mechanical specifications	1-17
Table 1-11: Environmental specifications	1-18
Table 1-12: Certifications and compliances	1-19
Table 2-1: Additional accessory connection information	2-2
Table 2-2: Line fuses	2-4
Table 4-1: Test equipment	4-18
Table 4-2: DC Voltage measurement accuracy	4-31
Table 4-3: Offset accuracy	4-35
Table 4-4: Maximum input voltage limit	4-39
Table 4-5: Analog bandwidth	4-43
Table 4-6: Delay between channels worksheet	4-49
Table 4-7: Delta time measurement	4-62
Table 4-8: Serial pattern data	4-80
Table 4-9: Word recognizer data	4-82
Table 4-10: Clock recovery input frequencies and baud rates	4-87
Table 6-1: External inspection check list	6-3
Table 6-2: Internal inspection check list	6-4
Table 6-3: Tools required for module removal	6-8
Table 6-4: Failure symptoms and possible causes	6-53
Table 6-5: Power supply voltages	6-58
Table 6-6: Power-on diagnostic tests	6-61
Table 6-7: Action required for module replaced	6-64
Table 6-8: BIOS Error messages (Bali)	6-64
Table 6-9: BIOS Error messages (Radisys)	6-66

Table 6-10: Beep codes (Bali)	6-68
Table 6-11: Beep codes (RadisyS)	6-69
Table 6-12: DIP switch functions	6-70
Table 6-13: Diagnostic LED	6-71
Table 7-1: Standard accessories	7-1
Table 7-2: Optional accessories	7-2

General Safety Summary

Review the following safety precautions to avoid injury and prevent damage to this product or any products connected to it. To avoid potential hazards, use this product only as specified.

Only qualified personnel should perform service procedures.

While using this product, you may need to access other parts of the system. Read the *General Safety Summary* in other system manuals for warnings and cautions related to operating the system.

To Avoid Fire or Personal Injury

Use Proper Power Cord. Use only the power cord specified for this product and certified for the country of use.

Connect and Disconnect Properly. Do not connect or disconnect probes or test leads while they are connected to a voltage source.

Ground the Product. This product is grounded through the grounding conductor of the power cord. To avoid electric shock, the grounding conductor must be connected to earth ground. Before making connections to the input or output terminals of the product, ensure that the product is properly grounded.

Observe All Terminal Ratings. To avoid fire or shock hazard, observe all ratings and markings on the product. Consult the product manual for further ratings information before making connections to the product.

Do Not Operate Without Covers. Do not operate this product with covers or panels removed.

Use Proper Fuse. Use only the fuse type and rating specified for this product.

Avoid Exposed Circuitry. Do not touch exposed connections and components when power is present.

Wear Eye Protection. Wear eye protection if exposure to high-intensity rays or laser radiation exists.

Do Not Operate With Suspected Failures. If you suspect there is damage to this product, have it inspected by qualified service personnel.

Do Not Operate in Wet/Damp Conditions.

Do Not Operate in an Explosive Atmosphere.

Keep Product Surfaces Clean and Dry.

Provide Proper Ventilation. Refer to the manual's installation instructions for details on installing the product so it has proper ventilation.

Symbols and Terms

Terms in this Manual. These terms may appear in this manual:



WARNING. *Warning statements identify conditions or practices that could result in injury or loss of life.*



CAUTION. *Caution statements identify conditions or practices that could result in damage to this product or other property.*

Terms on the Product. These terms may appear on the product:

DANGER indicates an injury hazard immediately accessible as you read the marking.

WARNING indicates an injury hazard not immediately accessible as you read the marking.

CAUTION indicates a hazard to property including the product.

Symbols on the Product. The following symbols may appear on the product:



Service Safety Summary

Only qualified personnel should perform service procedures. Read this *Service Safety Summary* and the *General Safety Summary* before performing any service procedures.

Do Not Service Alone. Do not perform internal service or adjustments of this product unless another person capable of rendering first aid and resuscitation is present.

Disconnect Power. To avoid electric shock, switch off the instrument power, then disconnect the power cord from the mains power.

Use Care When Servicing With Power On. Dangerous voltages or currents may exist in this product. Disconnect power, remove battery (if applicable), and disconnect test leads before removing protective panels, soldering, or replacing components.

To avoid electric shock, do not touch exposed connections.

Preface

This is the service manual for the TDS6000 Digital Storage Oscilloscope products. Read this preface to learn how this manual is structured, what conventions it uses, and where you can find other information related to servicing this product. Read the *Introduction* following this preface for safety and other important background information needed before using this manual for servicing this product.

Manual Structure

This manual is divided into chapters, which are made up of related subordinate topics. These topics can be cross referenced as sections.

Be sure to read the introductions to all procedures. These introductions provide important information needed to do the service correctly, safely, and efficiently.

Manual Conventions

This manual uses certain conventions that you should become familiar with before attempting service.

Modules

Throughout this manual, any replaceable component, assembly, or part is referred to by the term *module*. A module is composed of electrical and mechanical assemblies, circuit cards, interconnecting cables, and user-accessible controls.

Replaceable Parts

This manual refers to any field-replaceable assembly or mechanical part specifically by its name or generically as a replaceable part. In general, a replaceable part is any circuit board or assembly, such as the hard disk drive, or a mechanical part, such as the I/O port connectors, that is listed in the replaceable parts list of Chapter 10.

Safety

Symbols and terms related to safety appear in the *Service Safety Summary* found at the beginning of this manual.

Related Documentation

The oscilloscope comes with the following manuals:

- *TDS6000 Series User Manual*. Tektronix part number 071-7012-XX.
- *TDS6000 Series Quick Reference manual*. Tektronix part number 071-7013-XX.
- *TDS6000 Series Rackmount Kit (Option 1R) Instructions*. Tektronix part number 071-0716-XX.

Contacting Tektronix

Phone	1-800-833-9200*
Address	Tektronix, Inc. Department or name (if known) 14200 SW Karl Braun Drive P.O. Box 500 Beaverton, OR 97077 USA
Web site	www.tektronix.com
Sales support	1-800-833-9200, select option 1*
Service support	1-800-833-9200, select option 2*
Technical support	Email: techsupport@tektronix.com 1-800-833-9200, select option 3* 1-503-627-2400 6:00 a.m. - 5:00 p.m. Pacific time

* **This phone number is toll free in North America. After office hours, please leave a voice mail message. Outside North America, contact a Tektronix sales office or distributor; see the Tektronix web site for a list of offices.**

Specifications

This chapter contains the specifications for the TDS6000 Series. All specifications are guaranteed unless labeled “typical.” Typical specifications are provided for your convenience but are not guaranteed. Specifications that are marked with the ✓ symbol are checked in chapter four, *Performance Verification* of the service manual. Unless noted otherwise, all specifications apply to all TDS6000 Series oscilloscopes.

To meet specifications, the following conditions must be met:

- The oscilloscope must have been calibrated in an ambient temperature between 20 °C and 30 °C (68 °F and 86 °F).
- The oscilloscope must be operating within the environmental limits listed in Table 1-11.
- The oscilloscope must be powered from a source that meets the specifications listed in Table 1-9 on page 1-16.
- The oscilloscope must have been operating continuously for at least 20 minutes within the specified operating temperature range.
- You must perform the Signal Path Compensation procedure after the 20-minute warm-up period, and the ambient temperature must not change more than 5 °C without first repeating the procedure. See *Run the signal-path compensation routine* on page 4-6 for instructions to perform this procedure.

Product and Feature Description

Your TDS6000 Series is shown in Table 1-1.

Table 1-1: TDS6000 Series

Model	Number of channels	Bandwidth	Maximum sample rate (real time)
TDS6604	4	6 GHz	20 GS/s
TDS6404	4	4 GHz	20 GS/s

Acquisition Features

Separate Digitizers. Ensure accurate timing measurements with separate digitizers for each channel. Acquisition on multiple channels is always concurrent. The digitizers can also be combined to yield a higher sample rate on a single channel.

Long Record Lengths. Record lengths from 125,000 points when using channel 1 with 2 or channel 3 with 4, or any three channels, or all 4 channels. Up to 250,000 points when using channel 1 with 3, channel 1 with 4, channel 2 with 3, or channel 2 with 4, or any single channel.

Peak Detect Acquisition Mode. See pulses as narrow as 50 ps even at the slower time base settings. Peak detect helps you see noise and glitches in your signal.

Acquisition Control. Acquire continuously or set up to capture single shot acquisitions. Enable or disable optional acquisition features such as equivalent time.

Horizontal Delay. Use delay when you want to acquire a signal at a significant time interval after the trigger point. Toggle delay on and off to quickly compare the signal at two different points in time.

Signal Processing Features

Average, Envelope, and Hi Res Acquisition. Use Average acquisition mode to remove uncorrelated noise from your signal. Use Envelope to capture and display the maximum variation of the signal. Use Hi Res to increase vertical resolution for lower bandwidth signals.

Waveform Math. Set up simple math waveforms using the basic arithmetic functions or create more advanced math waveforms using the math expression editor. Waveform expressions can even contain measurement results and other math waveforms.

Spectral Analysis. Display spectral magnitude and phase waveforms based on your time-domain acquisitions. Control the oscilloscope using the traditional spectrum analyzer controls such as span and center frequency.

Display Features

Color LCD Display. Identify and differentiate waveforms easily with color coding. Waveforms, readouts, and inputs are color matched to increase productivity and reduce operating errors.

Zoom. To take advantage of the full resolution of the oscilloscope you can zoom in on a waveform to see the fine details. Both vertical and horizontal zoom functions are available.

-
- Measurement Features**
- Cursors.** Use cursors to take simple voltage, time, and frequency measurements.
 - Automatic Measurements.** Choose from a large palette of amplitude, time, and histogram measurements. You can customize the measurements by changing reference levels or by adding measurement gating.
- Trigger Features**
- Simple and Advanced Trigger Types.** Choose simple edge trigger or choose from eight advanced trigger types to help you capture a specific signal fault or event.
 - Dual Triggers.** Use the A (main) trigger system alone or add the B trigger to capture more complex events. You can use the A and B triggers together to set up a delay-by-time or delay-by-events trigger condition.
- Convenience Features**
- Autoset.** Use Autoset to quickly set up the vertical, horizontal, and trigger controls for a usable display.
 - Touch Screen Interface.** You can operate all oscilloscope functions (except the power switch) from the touch screen interface. If convenient, you can also install a mouse and keyboard to use the interface.
 - Toolbar or Menu Bar.** You can choose a toolbar operating mode that is optimized for use with the touch screen, or a PC-style menu-bar operating mode that is optimized for use with a mouse.
 - Open Desktop.** The oscilloscope is built on a Microsoft Windows software platform; the oscilloscope application program starts automatically when you apply power to the instrument. You can minimize the oscilloscope application and take full advantage of the built-in PC to run other applications. Moving waveform images and data into other applications is as simple as a copy/paste operation.
 - Dedicated Front Panel Controls.** The front panel contains knobs and buttons to provide immediate access to the most common oscilloscope controls. Separate vertical controls are provided for each channel. The same functions are also available through the screen interface.
 - Data Storage and I/O.** The oscilloscope has a removeable hard disk drive, a CD-RW drive, and a floppy disk drive that can be used for storage and retrieval of data. The oscilloscope has GPIB, USB, Centronics, and Ethernet ports for input and output to other devices.

Online Help. The oscilloscope has a complete online help system that covers all its features. The help system is context sensitive; help for the displayed control window is automatically shown if you touch the help button. Graphical aids in the help windows assist you in getting to the information you need. You can also access the help topics through a table of contents or index.

Specification Tables

Table 1-2: Channel input and vertical specifications

Characteristic	Description		
Input channels	Four		
Input coupling	DC and GND Channel input is disconnected from input termination when using GND coupling.		
✓ Input impedance, DC coupled	50 Ω ±2.5% at 25 °C (77 °F), ± 0.2% over 0 to 50 °C (122 °F)		
VSWR, typical	Input frequency, f_{in}	<100 mV/div	≥ 100 mV/div
	<2 GHz	1.5	1.1
	<3 GHz	2.0	1.2
	<6 GHz (TDS6604)	2.5	1.3
	<4 GHz (TDS6404)		
Maximum voltage at input	<1 V _{RMS} for <100 mV settings and <7 V _{RMS} for ≥ 100 mV settings		
Number of digitized bits	8 bits		
Sensitivity range	10 mV/div to 1 V/division, in a 1-2-5 sequence		
✓ DC gain accuracy	10 mV/div to 99.5 mV/div	± (2.5% +(2% × net offset))	
	≥ 100 mV/div to 1 V/div	± (2.5% +(2% × net offset/10))	

Table 1-2: Channel input and vertical specifications (Cont.)

Characteristic	Description	
✓ DC voltage measurement accuracy	<i>Measurement type</i>	<i>DC accuracy (in volts)</i>
Average acquisition mode (≥16 averages)	10 mV/div to 99.5 mV/div	$\pm[(2\% + (2\% \times \text{net offset})) \times \text{reading} + (\text{position} \times \text{V/division}) - \text{offset} + \text{offset accuracy} + 0.08 \text{ division} \times \text{V/division}]$
	≥ 100 mV/div	$\pm[(2\% + (2\% \times \text{net offset}/10)) \times \text{reading} + (\text{position} \times \text{V/division}) - \text{offset} + \text{offset accuracy} + 0.08 \text{ division} \times \text{V/division}]$
Delta voltage measurement between any two averages of ≥ 16 waveforms acquired under the same setup and ambient conditions	10 mV/div to 99.5 mV/div	$\pm((2\% + (2\% \times \text{net offset})) \times \text{reading}) + 0.16 \text{ division} \times \text{V/division setting}$
	≥ 100 mV/div	$\pm((2\% + (2\% \times \text{net offset}/10)) \times \text{reading}) + 0.16 \text{ division} \times \text{V/division setting}$
	<i>where, net offset = offset - (position × volts/division)</i>	
Nonlinearity, typical	< 1 DL, differential; ≤ 2 DL integral, independently based	
✓ Analog bandwidth	DC 50 Ω coupling, Full bandwidth, TCA-SMA or TCA-N adapter, operating ambient 15° C to 50° C (59° F to 122° F), derated by 30 MHz/° C below 15° C (59° F)	
	<i>SCALE range</i>	<i>Bandwidth</i>
	≥ 10 mV/div	TDS6604
		TDS6404
		DC to ≥ 6 GHz
		DC to ≥ 4 GHz
Analog bandwidth with P7240 active probe or TCA-BNC adapter for TDS6404	DC 4 GHz, Full bandwidth, operating ambient 15° C to 30° C (59° F to 86° F), derated by 20 MHz/° C above 30° C (86° F)	
Analog bandwidth with P7260 active probe or TCA-BNC adapter for TDS6604	DC 6 GHz, Full bandwidth, operating ambient 15° C to 30° C (59° F to 86° F), derated by 20 MHz/° C above 30° C (86° F)	
Calculated rise time, typical	70ps (TDS6604)	
	XXps (TDS6404)	

Table 1-2: Channel input and vertical specifications (Cont.)

Characteristic	Description	
Step response settling errors, typical	Full bandwidth	
	<i>SCALE range and step amplitude</i>	<i>Settling error at time after step</i>
	10 mV/div to 99.5 mV/div, with ≤ 1.5 V step	20 ns: $\leq 2\%$ 1 ms: $\leq 0.1\%$
	100 mV/div to 1 V/div, with ≤ 3 V step	20 ns: $\leq 2\%$ 1 ms: $\leq 0.2\%$
Pulse response, peak detect or envelope mode	Sample rate setting	Minimum pulse width
	2.5 GS/s or less	50 ps
Position range	± 5 divisions	
Offset range	<i>SCALE range</i>	<i>Offset range</i>
	10 mV/div to 50 mV/div	± 0.50 V
	50.5 mV/div to 100 mV/div	± 0.25 V
	101 mV/div to 500 mV/div	± 5 V
	505 mV/div to 1 V/div	± 2.5 V
✓ Offset accuracy	<i>SCALE range</i>	<i>Offset range</i>
	10 mV/div to 99.5 mV/div	$\pm(0.5\% \times \text{net offset} + 1.5 \text{ mV} + 0.1 \text{ div} \times \text{V/div setting})$
	100 mV/div to 1 V/div	$\pm(0.5\% \times \text{net offset} + 15 \text{ mV} + 0.1 \text{ div} \times \text{V/div setting})$
	<i>where, net offset = offset - (position \times volts/division)</i>	

Table 1-2: Channel input and vertical specifications (Cont.)

Characteristic	Description	
Effective bits, typical	Nine division sine wave input at the indicated frequency, sampled at 50 mV/division and 20 GS/s.	
	<i>Input frequency</i>	<i>Effective bits</i>
	1 MHz	6.0 bits
	1 GHz	5.7 bits
	2 GHz	5.3 bits
	3 GHz	5.1 bits
	4 GHz	4.9 bits
	5 GHz	4.5 bits
	6 GHz	3.5 bits
✓ Delay between channels	≤ 30 ps between any two channels with the same scale and coupling settings	
✓ Channel-to-channel cross-talk	≥20:1 at rated bandwidth, and ≥ 80:1 at ≤ 1.5 GHz or the rated bandwidth, whichever is less. Assumes two channels with the same scale settings	

Table 1-3: Horizontal and acquisition system specifications

Characteristic	Description	
Real-time sample rate range	<i>Number of channels acquired</i>	<i>Sample rate range</i>
	1 or 2	5 S/s to 20GS/s
	3 or 4	5 S/s to 10GS/s
Equivalent-time sample rate or interpolated waveform rate range	10GS/s, 12.5GS/s, 20GS/s, 25GS/s, 40GS/s, 50GS/s, 62.5GS/s, 80GS/s, 100GS/s, 125GS/s, 160GS/s, 200GS/s, 250GS/s, 312.5GS/s, 320GS/s, 400GS/s, 500GS/s, 625GS/s, 800GS/s, 1TS/s	
Acquisition modes	Sample, Peak Detect, Hi Res, Average, and Envelope	
Record length	Maximum record length supported by acquisition hardware, at any sample rate	
	<i>Mode</i>	<i>Channels</i>
	Sample	1 channel only
	Sample	2 channels only: channel 1 with 3, channel 1 with 4, channel 2 with 3, or channel 2 with 4
	Sample	2 channels only: channel 1 with 2, or channel 3 with 4
	Sample	3 or 4 channels
	Hi Res	Any
	<i>Record length</i>	
		250,000
		250,000
		125,000
		125,000
		12,500
Seconds/division range	50 ps/div to 10 s/div	
✓ Internal time-base reference frequency	10 MHz ± 2.5 ppm over any ≥ 100 ms interval. Aging < 1 ppm per year	
✓ Long term sample rate and delay time accuracy	±2.5 ppm over any ≥100 ms interval	
Aperture uncertainty, typical	Short term: ≤ 1.5 ps rms, records having duration ≤ 100 ms ≤ 800 fs rms, records having duration ≤ 10 μs Long term: ≤ 15 parts per trillion rms, records having duration ≤ 1 minute	
Time base delay time range	16 ns to 250 s	

Table 1-3: Horizontal and acquisition system specifications (Cont.)

Characteristic	Description	
✓ Delta time measurement accuracy	For a single channel, with signal amplitude > 5 divisions, reference level set at 50%, interpolation set to sin(x)/x, volts/division set to ≥ 5 mV/div, with risetime $>1.4 \times T_s$ and $<4 \times T_s$ or 150 ps (whichever is greater) and acquired ≥ 10 mV/Div, where T_s is the sample period.	
	<i>Conditions</i>	<i>Accuracy</i>
	Single shot signal, Sample acquisition mode, Full bandwidth	$\pm (0.06/\text{sample rate} + 2.5 \text{ ppm} \times \text{reading})$ RMS
	Average acquisition mode, >100 averages, Full bandwidth	$\pm (0.3/\text{sample rate} + 2.5 \text{ ppm} \times \text{reading})$ peak
	Average acquisition mode, >100 averages, Full bandwidth	$\pm (4 \text{ ps} + 2.5 \text{ ppm} \times \text{reading})$

Table 1-4: Trigger specifications

Characteristic	Description	
Trigger jitter, typical	Internal: 7ps rms for low frequency squarewave with 5 div amplitude, fast rise time <200 ps, repetition rate <10 kHz	
	Auxiliary: 10ps rms for 5 V step signal with rise time <2 ns and repetition rate <10 kHz	
✓ Edge Trigger Sensitivity	All sources, for vertical scale settings ≥ 10 mV/div and ≤ 1 V/div	
	<i>Trigger Source</i>	<i>Sensitivity</i>
	Main trigger, Ch1 - Ch4	≤ 0.35 div DC to 50 MHz increasing to 1.5 div at 3 GHz
	Delayed trigger, Ch1 - Ch4	0.35 div from DC to 50 MHz, increasing to 1 div at 1.5 GHz
	Auxiliary input	250 mV from DC to 50 MHz, increasing to 350 mV at 500 MHz

Table 1-4: Trigger specifications (Cont.)

Characteristic	Description	
Edge trigger sensitivity, typical	All sources, for vertical scale settings ≥ 10 mV/div and ≤ 1 V/div	
	<i>Trigger coupling</i>	<i>Sensitivity</i>
	NOISE REJ	3 \times the DC-coupled limits
	AC	Same as DC-coupled limits for frequencies > 100 Hz, attenuates signals < 100 Hz
	HF REJ	Same as DC coupled limits for frequencies < 20 kHz, attenuates signals > 20 kHz
	LF REJ	Same as DC coupled limits for frequencies > 200 kHz, attenuates signals < 200 kHz
Auxiliary trigger input resistance, typical	≥ 1.5 k Ω	
Maximum trigger input voltage, typical	± 7.5 V (DC + peak AC)	
Lowest frequency for Set Level to 50%, typical	50 Hz	
Advanced trigger sensitivity, typical	For vertical scale settings ≥ 10 mV/div and ≤ 1 V/div at TekConnect connector Advanced triggers: 1.0 div, from DC to 500 MHz Runt type: 1.0 div	

Table 1-4: Trigger specifications (Cont.)

Characteristic	Description	
Advanced trigger timing	For vertical scale settings ≥ 10 mV/div and ≤ 1 V/div	
	<i>Minimum recognizable event width or time</i>	<i>Minimum re-arm time to recognize next event</i>
Glitch type	Minimum glitch width = 1 ns	2 ns + (5% of glitch width setting or 25 ns, whichever is smaller)
Runt type	Minimum runt width = 2 ns	2 ns
Time-qualified runt type	Minimum runt width = 2 ns	8.5 ns + (5% of runt width setting or 25 ns, whichever is smaller)
Width type	Minimum difference between upper and lower limits = 1 ns	2 ns + (5% of upper limit setting or 25 ns, whichever is smaller)
Transition type	Minimum transition time = 600 ps	8.5 ns + (5% of transition time setting or 25 ns, whichever is smaller)
State type, typical	Minimum true time before clock edge = 1 ns	1 ns
	Minimum true time after clock edge = 1 ns	
Setup/Hold type, typical	<i>Minimum clock pulse width from active edge to inactive edge</i>	
	<i>User's Hold time</i>	<i>Limits</i>
	+2.6 ns	2 ns

Table 1-4: Trigger specifications (Cont.)

Characteristic	Description	
Advanced trigger timer ranges	<i>Limits</i>	
Glitch type	1 ns to 1 s	
Runt type, time qualified	1 ns to 1 s	
Width type	1 ns to 1 s	
Timeout type	1 ns to 1 s	
Transition type	1 ns to 1 s	
Pattern type	1 ns to 1 s	
Setup/Hold type	<i>Setup and Hold timers</i>	<i>Limits</i>
	Setup time (time from data transition to clock edge)	-100 ns to +100 ns
	Hold time (time from clock edge to data transition)	-1 ns to +102 ns
	Setup time + Hold time (algebraic sum of the two settings)	+2 ns
✓ Advanced trigger timer accuracy	For Glitch, Timeout, or Width types	
	<i>Time range</i>	<i>Accuracy</i>
	1 ns to 500 ns	±(20% of setting + 0.5 ns)
	520 ns to 1 s	±(0.01% of setting + 100 ns)
Trigger level or threshold range	<i>Trigger Source</i>	<i>Sensitivity</i>
	Any channel	±12 divisions from center of screen
	Auxiliary input	±4.5 V
	Line	±0 V, not settable
Trigger level or threshold accuracy, typical	Edge trigger, DC coupling, for signals having rise and fall times >1 ns	
	<i>Trigger Source</i>	<i>Accuracy</i>
	Any channel	± [(2% × setting - net offset) + (0.35 div × volts/div setting) + offset accuracy]
	Auxiliary	Not specified
<i>where, net offset = offset - (position × volts/division)</i>		

Table 1-4: Trigger specifications (Cont.)

Characteristic	Description	
B Event (Delayed) trigger	<i>Trigger After Time</i>	<i>Trigger on nth Event</i>
Range	Delay time = 16 ns to 250 s	Event count = 1 to 10 ⁷
Minimum time between arm (A Event) and trigger (B Event), typical	2 ns from the end of the time period to the B trigger event	2 ns between the A trigger event and the first B trigger event
Minimum pulse width, typical	—	B event width ≥ 1 ns
Maximum frequency, typical	—	B event frequency ≤ 500 MHz
Trigger position error, typical	Edge trigger, DC coupling, for signals having a slew rate at the trigger point of ≥ 0.5 division/ns	
	<i>Acquisition mode</i>	<i>Error</i>
	Sample, Average	± (1 waveform interval + 200 ps)
	Peak Detect, Envelope	± (2 waveform interval + 200 ps)
Trigger holdoff range	250 ns to 12 s, minimum resolution is 8 ns for settings ≤ 1.2 μs. A dither of ± 4 ns is added to the holdoff setting	

Table 1-5: Serial Trigger specifications (Option ST Only)

Characteristic	Description	
Serial trigger number of bits	32	
Serial trigger encoding types	NRZ	
✓Serial trigger baud rate limits	Up to 1.25 Gbaud	
Serial trigger, serial word recognizer position accuracy	Edge trigger, DC coupling, for signals having a slew rate at the trigger point of ≥ 0.5 division/ns	
	<i>Acquisition mode</i>	<i>Error</i>
	Sample, Average	± (1 waveform interval + 200 ps)
	Peak Detect, Envelope	± (2 waveform interval + 200 ps)

Table 1-6: Display specifications

Characteristic	Description
Display type	211.2 mm (8.4 in) (W) × 158.4 mm (6.3 in) (H), 264 mm (10.4 in) diagonal, liquid crystal active-matrix color display
Display resolution	640 horizontal × 480 vertical pixels
Pixel pitch	0.33 mm horizontal, 0.22 mm vertical
Response time, typical	50 ms, white to black
Display refresh rate	59.94 frames per second
Viewing angle, typical	80 degrees
Displayed intensity levels	Supports Windows SVGA high-color mode (16-bit)

Table 1-7: Input/output port specifications

Characteristic	Description
Rear-panel I/O ports	Ports located on the rear panel
SVGA video port	Upper video port, DB-15 female connector, connect a second monitor to use dual-monitor display mode, supports Basic requirements of PC99 specifications
Parallel port (IEEE 1284)	DB-25 connector, supports the following modes: - standard (output only) bidirectional (PS-2 compatible) bidirectional enhanced parallel port (IEEE 1284 standard, mode 1 or mode 2, v 1.7) - bidirectional high-speed extended capabilities
Serial port	DB-9 COM1 port, uses NS16C550-compatible UARTS, transfer speeds up to 115.2 kb/s
Keyboard port	PS-2 compatible, oscilloscope power must be off to make connection
Mouse port	PS-2 compatible, oscilloscope power must be off to make connection
LAN port	RJ-45 connector, supports 10 base-T and 100 base-T
Audio ports	Miniature phone jacks for stereo microphone input and stereo line output
USB port	Allows connection or disconnection of USB keyboard and/or mouse while oscilloscope power is on
GPIB port	IEEE 488.2 standard interface

Table 1-7: Input/output port specifications (Cont.)

Characteristic	Description	
✓ Probe Compensator Output	Front-panel BNC connector, requires Probe Cal Deskew Fixture for probe attachment	
	<i>Output voltage</i>	<i>Frequency</i>
	400 mV (from base to top) ± 20% into a ≥ 10 kΩ load (Vol = 1.6 V, Voh = 2 V typical)	1 kHz ± 5%
✓ Analog Signal Output amplitude	BNC connector, provides a buffered version of the signal that is attached to the channel 3 input when channel 3 is the trigger source 20 mV/div ± 20% into a 1 MΩ load 10 mV/div ± 20% into a 50 Ω load Offset: between -100 mV and -170 mV into 50 Ω	
✓ Auxiliary Output levels	Front-panel BNC connector, provides a TTL-compatible pulse (polarity selectable) for each A or B trigger (selectable)	
	<i>V_{out high}</i>	<i>V_{out low (true)}</i>
	≥2.5 V into open circuit, ≥1.0 V into 50 Ω load	≤0.7 V with ≤4 mA sink, ≤0.25 V into 50 Ω load
Auxiliary Output pulse width, typical	Pulse width varies, 1 μs minimum	
External reference	Run SPC whenever the external reference is more than 2000 ppm different than the internal reference or the reference at which SPC was last run.	
Frequency range	9.8 MHz to 10.2 MHz.	
Input voltage, maximum	7 V _{p-p}	
Input impedance	1.5 kΩ, 30 pF. Measure impedance at >100 kHz to make the blocking capacitor invisible	
✓ External reference	Run SPC whenever the external reference is more than 2000 ppm different than the internal reference or the reference at which SPC was last run.	
Input sensitivity	≥ 200 mV _{p-p}	
✓ Internal reference output		
Frequency	10 MHz ± ≈ 2.5 ppm over any ≥ 100 ms interval	
Output voltage	<i>V_{out high}</i>	<i>V_{out low (true)}</i>
	≥2.5 V into open circuit, ≥1.0 V into 50 Ω load	≤0.7 V with ≤4 mA sink, ≤0.25 V into 50 Ω load

Table 1-8: Data storage specifications

Characteristic	Description
Nonvolatile memory retention time, typical	≥ 5 years
Floppy disk	Front-panel 3.5 in floppy disk drive, 1.44 MB capacity
CDROM-RW	Rear-panel CDROM-RW drive, read write
Hard disk	Rear-panel, removeable hard disk drive, ≥ 4.3 GB capacity

Table 1-9: Power source specifications

Characteristic	Description
Power consumption	≤ 400 Watts (400 VA)
Source voltage and frequency	100 to 240 V ± 10%, 50 Hz to 60 Hz 115 V ± 10%, 400 Hz CAT II
Fuse rating	Either one of the following sizes can be used, each size requires a different fuse cap. Both fuses must be the same type
0.25 in × 1.25 in size	UL198G and CSA C22.2, No. 59, fast acting: 8 A, 250 V (Tektronix part number 159-0046-00, Bussman ABC-8, Littelfuse 314008)
5 mm × 20 mm size	IEC127, sheet 1, fast acting “F”, high breaking capacity: 6.3 A, 250 V (Bussman GDA 6.3, Littelfuse 21606.3)

Table 1-10: Mechanical specifications

Characteristic	Description	
Weight		
Benchtop configuration	15 kg (33 lbs) with fully accessorized pouch 24 kg (53 lbs) when packaged for domestic shipment	
Rackmount kit	18.6 kg (41 lbs) rackmounted instrument 5.6 kg (12.5 lbs) kit packaged for domestic shipment	
Dimensions		
Benchtop configuration	With front cover	Without front cover
	278 mm (10.95 in) height, 330 mm (13 in) with feet extended 455 mm (17.9 in) width 435 mm (17.13 in) depth	277 mm (10.9 in) height, 330 mm (13 in) with feet extended 455 mm (17.9 in) width 426 mm (16.75 in) depth
Rackmount configuration (Option 1R)	With rack handles	Without rack handles
	267 mm (10.5 in) height 502 mm (19.75 in) width 486 mm (19.13 in) depth	267 mm (10.5 in) height 482 mm (19 in) width 435 mm (17.13 in) depth
Cooling	Fan-forced air circulation with no air filter.	
Required clearances	Top	0 mm (0 in)
	Bottom	19 mm (0.75 in) minimum or 0 mm (0 in) when standing on feet, flip stands down
	Left side	76 mm (3 in)
	Right side	76 mm (3 in)
	Front	0 mm (0 in)
	Rear	0 mm (0 in) on rear feet
Construction material	Chassis parts are constructed of aluminum alloy, front panel is constructed of plastic laminate, circuit boards are constructed of glass laminate, outer shell is molded and textured from a polycarbonate/ABS blend	

Table 1- 11: Environmental specifications

Characteristic	Description
Temperature, operating	0 °C to +50 °C (32 °F to +122 °F), excluding floppy disk and CDROM-RW drives +10 °C to +45 °C (50 °F to +113 °F), including floppy disk and CDROM-RW drives
Nonoperating	-22 °C to +60 °C (71 °F to +140 °F)
Humidity, operating	20% to 80% relative humidity with a maximum wet bulb temperature of +29 °C (+84 °F) at or below +50 °C (+122 °F), noncondensing Upper limit derated to 25% relative humidity at +50 °C (+122 °F)
Nonoperating	With no diskette in floppy disk drive 5% to 90% relative humidity with a maximum wet bulb temperature of +29 °C (+84 °F) at or below +60 °C (+140 °F), noncondensing Upper limit derated to 20% relative humidity at +60 °C (+140 °F)
Altitude, operating	3,048 m (10,000 ft)
Nonoperating	12,190 m (40,000 ft)
Random vibration, operating	0.27 g _{RMS} from 5 Hz to 500 Hz, 10 minutes on each axis, 3 axes, 30 minutes total, with floppy disk and CDROM-RW installed
Nonoperating	2.28 g _{RMS} from 5 Hz to 500 Hz, 10 minutes on each axis, 30 minutes total, 3 axes

Table 1-12: Certifications and compliances

Category	Standards or description
EC Declaration of Conformity - EMC	<p>Meets intent of Directive 89/336/EEC for Electromagnetic Compatibility. Compliance was demonstrated to the following specifications as listed in the Official Journal of the European Union:</p> <p>EN 61326 Emissions ^{1, 3} Class A Radiated and Conducted Emissions</p> <p>EN 61326 Immunity ^{1,2,4}</p> <p>IEC 1000-4-2 Electrostatic Discharge Immunity ±4 kV contact discharge, ±8 kV air discharge, performance criterion B</p> <p>IEC 1000-4-3 RF field immunity 3 V/m, 80 MHz to 1 GHz, 80% amplitude modulated with a 1 kHz sinewave performance criterion A</p> <p>IEC 1000-4-4 Electrical Fast Transient/Burst Immunity 1 kV on AC mains, 500 V on I/O cables, performance criterion B</p> <p>IEC 1000-4-5 AC Surge Immunity 1 kV differential mode, 2 kV common mode, performance criterion B</p> <p>IEC 1000-4-6 RF Conducted Immunity 3 V, 150 kHz to 80 MHz, amplitude modulated with a 1 kHz sinewave, performance criterion A</p> <p>IEC 1000-4-11 AC Mains Voltage Dips and Interruption Immunity 100% reduction for one cycle, performance criterion B</p> <p>EN 61000-3-2 Power Harmonic Current Emissions</p> <p>¹ If interconnect cables are used, they must be low-EMI shielded cables such as the following Tektronix part numbers or their equivalents: 012-0991-01, 012-0991-02 or 012-0991-03 GPIB Cable; 012-1213-00 (or CA part number 0294-9) RS-232 Cable; 012-1214-00 Centronics Cable; or LCOM part number CTL3VGAMM-5 VGA Cable.</p> <p>² The performance criteria for when the oscilloscope is subjected to the conditions described above are defined as follows: A — 10 mV/division to 1 V/division: ≤0.4 division waveform displacement or ≤0.8 division increase in peak-to-peak noise 5 mV/division and 2 mV/division, typical: ≤8 mV increase in peak-to-peak noise B — temporary, self-recoverable degradation or loss of performance is allowed, but no change of actual operating state or loss of stored data is allowed C — temporary loss of function is allowed provided that the function is self recoverable or can be restored by the operation of the controls</p> <p>³ Radiated emissions may exceed the levels specified in EN 61326 when this oscilloscope is connected to a test object.</p> <p>⁴ USB mouse and keyboard only, performance criterion C. Normal USB keyboard or mouse operation can be restored by unplugging and reconnecting the USB connector to the oscilloscope.</p>
Australia/New Zealand Declaration of Conformity — EMC	Complies with EMC provision of Radiocommunications Act per the following standard(s): AS/NZS 2064.1/2 Industrial, Scientific, and Medical Equipment: 1992

Table 1-12: Certifications and compliances (Cont.)

Category	Standards or description
EC Declaration of Conformity - Low Voltage	<p>Compliance was demonstrated to the following specification as listed in the Official Journal of the European Union:</p> <p>Low Voltage Directive 73/23/EEC, amended by 93/68/EEC</p> <p>EN 61010-1/A2:1995 Safety requirements for electrical equipment for measurement control and laboratory use.</p>
U.S. Nationally Recognized Testing Laboratory Listing	<p>UL3111-1, First Edition Standard for electrical measuring and test equipment.</p>
Canadian Certification	<p>CAN/CSA C22.2, No. 1010.1-92 Safety requirements for electrical equipment for measurement, control, and laboratory use.</p>
Additional Compliance	<p>IEC61010-1 Safety requirements for electrical equipment for measurement, control, and laboratory use.</p>
Installation (Overvoltage) Category	<p>Terminals on this product may have different installation (overvoltage) category designations. The installation categories are:</p> <p>CAT III Distribution-level mains (usually permanently connected). Equipment at this level is typically in a fixed industrial location.</p> <p>CAT II Local-level mains (wall sockets). Equipment at this level includes appliances, portable tools, and similar products. Equipment is usually cord-connected.</p> <p>CAT I Secondary (signal level) or battery operated circuits of electronic equipment.</p>
Pollution Degree	<p>A measure of the contaminates that could occur in the environment around and within a product. Typically the internal environment inside a product is considered to be the same as the external. Products should be used only in the environment for which they are rated.</p> <p>Pollution Degree 2 Normally only dry, nonconductive pollution occurs. Occasionally a temporary conductivity that is caused by condensation must be expected. This location is a typical office/home environment. Temporary condensation occurs only when the product is out of service.</p>
Safety Certification Compliance	
Equipment Type	Test and measuring
Safety Class	Class 1 (as defined in IEC 61010-1, Annex H) - grounded product
Pollution Degree	Pollution Degree 2 (as defined in IEC 61010-1). Note: Rated for indoor use only.

Operating Information

This chapter covers installation information and basic operation instructions.

Installation

The basic operating software is already installed on the hard disk. Refer to *Software Installation* on page 2-6 for instructions on reinstalling the software.



CAUTION. *Be sure you have an emergency startup disk. You will need this disk if you ever have to reinstall the Windows operating system. Refer to Create an Emergency Startup Disk on page 2-5.*

Before You Start

Verify that all parts and accessories for the oscilloscope are available. Use the graphical packing list that came with the oscilloscope to determine the necessary parts and accessories. You should also verify that the following items are available:

- The correct power cords
- The product-software CD set that includes installation copies of the software installed on the oscilloscope
- All the accessories necessary to operate the oscilloscope

Environmental Considerations

The oscilloscope is designed to operate on a bench or on a cart in the normal position (on the bottom feet). For proper cooling, at least three inches (7.62 cm) of clearance is required on both sides of the oscilloscope, and the bottom requires the clearance provided by the oscilloscope feet.

If you operate the oscilloscope while it is resting on the rear feet, make sure that you properly route any cables coming out of the rear of the oscilloscope to avoid damaging them.



CAUTION. *Keep the bottom and sides of the oscilloscope clear of obstructions to ensure proper cooling.*

Tables 1-9 and 1-11 on pages 1-16 and 1-18 list the operating requirements for the oscilloscope. Power source, temperature, humidity, and altitude are listed.

Connect the Peripherals

The peripheral connections are the same as those you would make on a personal computer. The connection points are shown in Figure 2-1 on page 2-3. See Table 2-1 for additional connection information.

Table 2-1: Additional accessory connection information

Item	Description
Monitor	If you use a non-standard monitor, you may need to change the the display settings to achieve the proper resolution for your monitor.
Printer	Connect the printer to the EPP (enhanced parallel port) connector directly. If your printer has a DB-25 connector, use the adapter cable that came with your printer to connect to the EPP connector. For information on printer usage, see <i>Printing Waveforms</i> in your user oscilloscope manual.
Rackmount	Refer to the <i>TDS7000 Rackmount Installation Instructions</i> for information on installing the rackmount kit.
Other	Refer to the Application release notes on your product CD set for possible additional accessory installation information not covered in this manual.



WARNING. Before installing accessories to connectors (mouse, keyboard, etc.), power off the oscilloscope. See Powering Off the Oscilloscope on page 2-5.

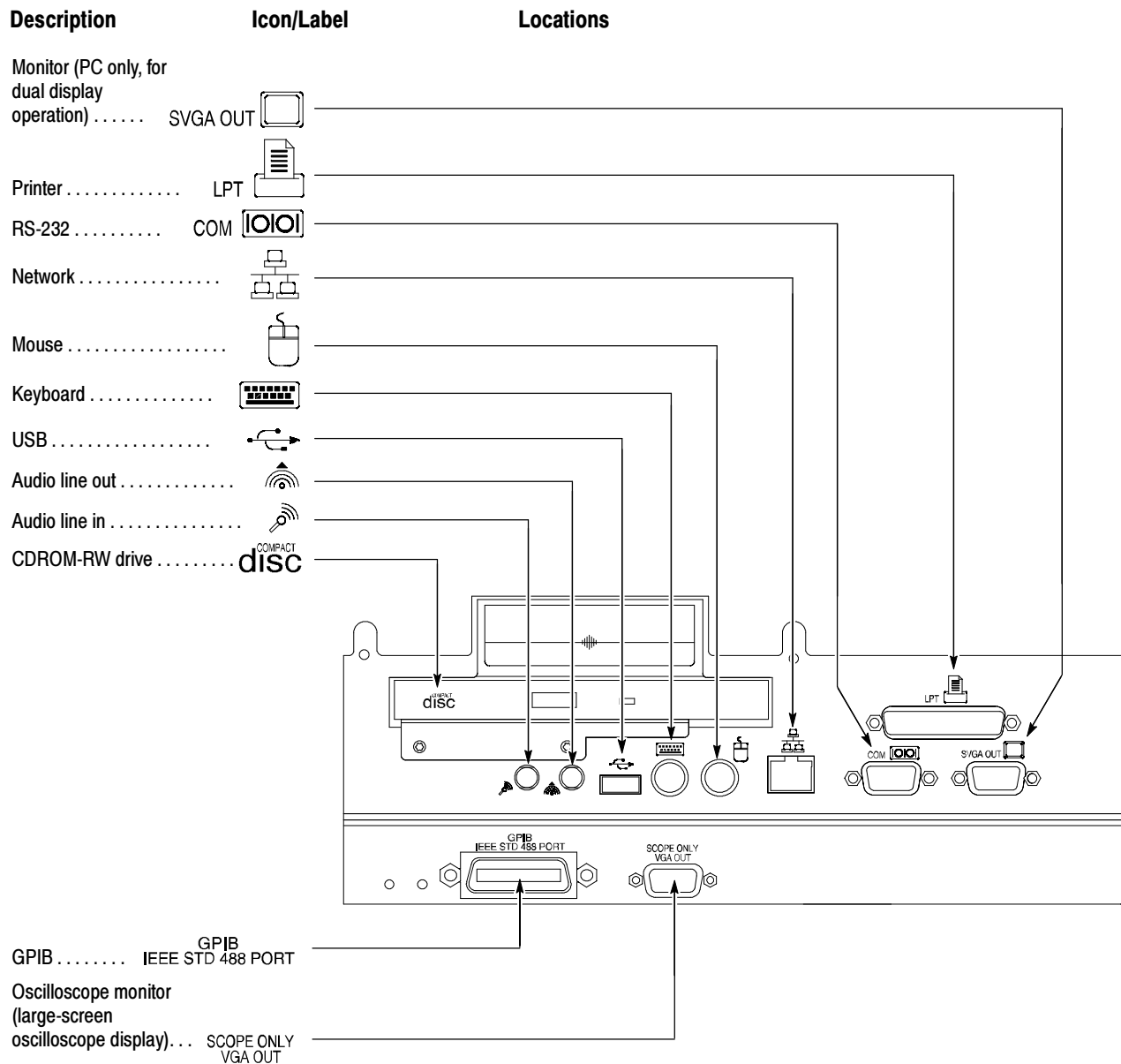

Figure 2-1: Locations of peripheral connectors on rear panel

Power On the Instrument

Follow these steps to power on the instrument.

1. Check that the line fuses are correct for your application. Both fuses must be the same rating and type. Fuse types require an unique cap and fuseholder. See Table 2-2 and Figure 2-2.

Table 2-2: Line fuses

Fuse type	Rating	Fuse part number	Cap & fuseholder part number
0.25 x 1.250 inch	8 A, fast blow, 250 V	159-0046-00	200-2264-00
5 x 20 mm	6.3 A, fast blow, 250 V	159-0381-00	200-2265-00

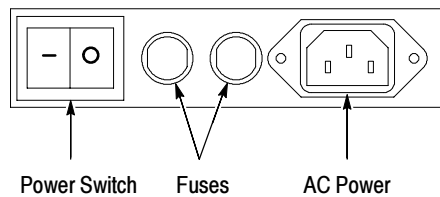

Figure 2-2: Line fuse and power cord connector locations, rear panel



CAUTION. Connect the keyboard, mouse, and other accessories before applying power to the product.

2. Connect the power cord.
3. If you have an external monitor, connect the power cord and power on the monitor.
4. Turn the Power switch on at the rear panel. (See Figure 2-2 for switch location.)
5. If the oscilloscope does not power on, press the On/Standby switch to power on the instrument (see Figure 2-3 for the switch location).
6. Wait for the boot routine and low-level self test to complete.

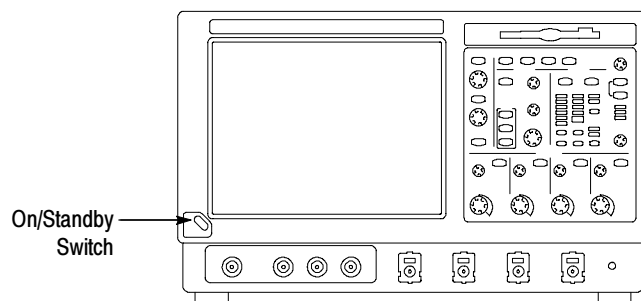

Figure 2-3: On/Standby switch location

Powering Off the Oscilloscope

The oscilloscope has a built-in soft power-off function that safely powers off the oscilloscope when you press the On/Standby switch.

To completely remove power to the instrument, perform the shutdown just described, and then set the power switch on the rear panel to off.

Create an Emergency Startup Disk

Now that you have completed the basic installation process, you should create an emergency startup disk that you can use to restart your instrument in case of a major hardware or software failure. You should create this disk, and then store it in a safe place.



CAUTION. Create this disk and store it in a safe place. It may allow you to recover your Windows installation without rebuilding the entire instrument hard disk.

The emergency startup disk contains basic files to restart your instrument. It also contains files to check and format the hard disk.

Follow these steps to create the emergency startup disk:

1. Minimize the oscilloscope application by selecting Minimize from the File menu.
2. Select the Windows Start button, point to Settings, and then click Control Panel.
3. In the Control Panel, double-click Add/Remove Programs.
4. Click the Startup Disk tab.
5. Insert a floppy disk into the disk drive and follow the on-screen instructions to create the startup disk.

Software Installation

This section describes how to install the system software found on the product-software CD that accompanies this product. The instrument ships with the product software installed, so only perform these procedures if reinstallation becomes necessary.

Software Release Notes. Read the software release notes README.TXT ASCII file on the product-software CD before performing installation procedures. This file contains additional installation and operation information that supercedes other product documentation.

To view the README.TXT file, open the Notepad Windows accessory and open the file on the product-software CD. After installation, you can also read the copy from a directory on the product:

C:\Program Files\Tds6000\ReadMe.txt

Operating System Restoration. Use the procedure that accompanies your *Operating System Restore* CD should reinstalling system software become necessary.

The compact disc contains the files necessary to restore the Windows operating system and necessary drivers for the oscilloscope.

The Windows operating system and drivers are factory installed on the oscilloscope hard disk. The compact disc serves as a backup in the event that you have to rebuild the hard drive. You must restore the Windows operating system before you can install the oscilloscope firmware and other product software.

Application Installation. Use the procedures that accompany your *Product Software* CD should reinstalling the oscilloscope application software become necessary.

The compact disc contains the files necessary to restore the oscilloscope application and other software for the oscilloscope.

Operating Information

This section covers basic operation information so that you can operate and prepare to service the instrument.

Back Up User Files

You should always back up your user files on a regular basis. Use the Microsoft Backup tool to back up files stored on the hard disk. The Backup tool is located in the System Tools folder in the Accessories folder.

1. Minimize the oscilloscope application by selecting Minimize from the File menu.
2. Select the Windows Start button, point to Programs, Accessories, System Tools, and then click Backup.
3. Use the Microsoft Backup tool to select your backup media and to select the files and folders that you want to back up. Use the online help for information on using the Backup tool. You can back up to the floppy drive, or to a third-party storage device over the printer port (rear panel).

User Interface Map

This section shows the main parts of the user interface.

The following illustration shows the oscilloscope in the Menu bar mode. All features of the oscilloscope can be accessed through the menus using a mouse or the touch screen.

When the oscilloscope is in the Tool bar mode, most of the control windows can be accessed by touching buttons at the top of the display.

Menu Bar: Access to data I/O, printing, online help system, and oscilloscope functions here

Status Bar: Display of acquisition status, mode, and number of acquisitions; trigger status; date; and time

Waveform Handle: Touch and drag to change vertical position of waveform. Touch the handle and change the position and scale using the multipurpose knobs

Display: Live, reference, & math waveforms display here, along with cursors

Controls Status: Quick reference to vertical, horizontal, and trigger selections, scale, and parameters

Buttons/Menu. Touch to toggle between tool-bar and menu-bar modes

Multipurpose Knob Readouts. Adjust parameters controlled by multipurpose knobs

Readouts: Display cursor readouts and measurement readouts in this area, selectable from the menu bar or tool bar

If a control menu is displayed, these readouts move to the graticule area

Front Panel Controls Map Many of the oscilloscope functions can be controlled directly from the front panel controls or in conjunction with the touch-screen interface.

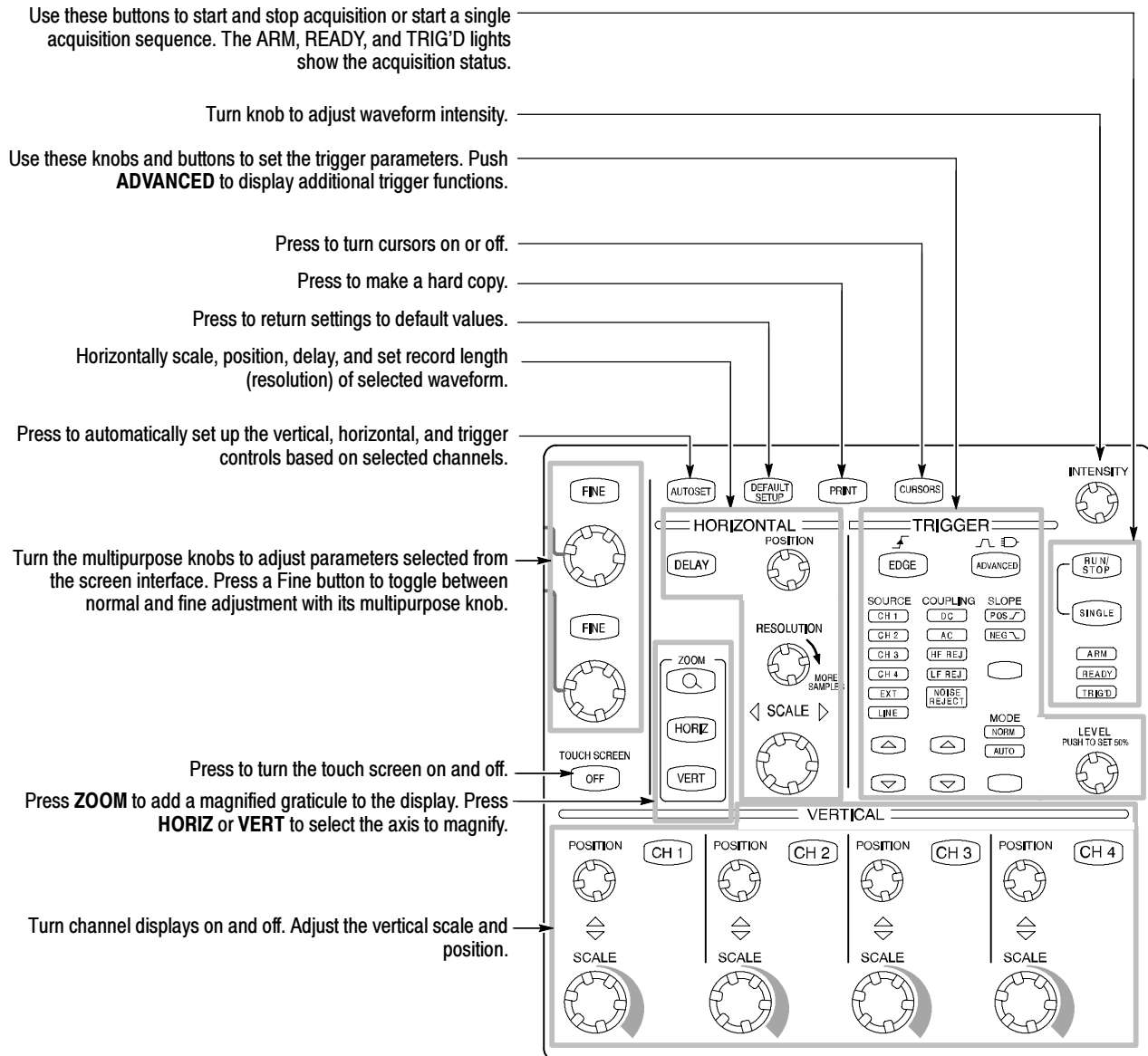

Front Panel I/O Map

The following illustration shows the input/output connectors and floppy disk drive location.

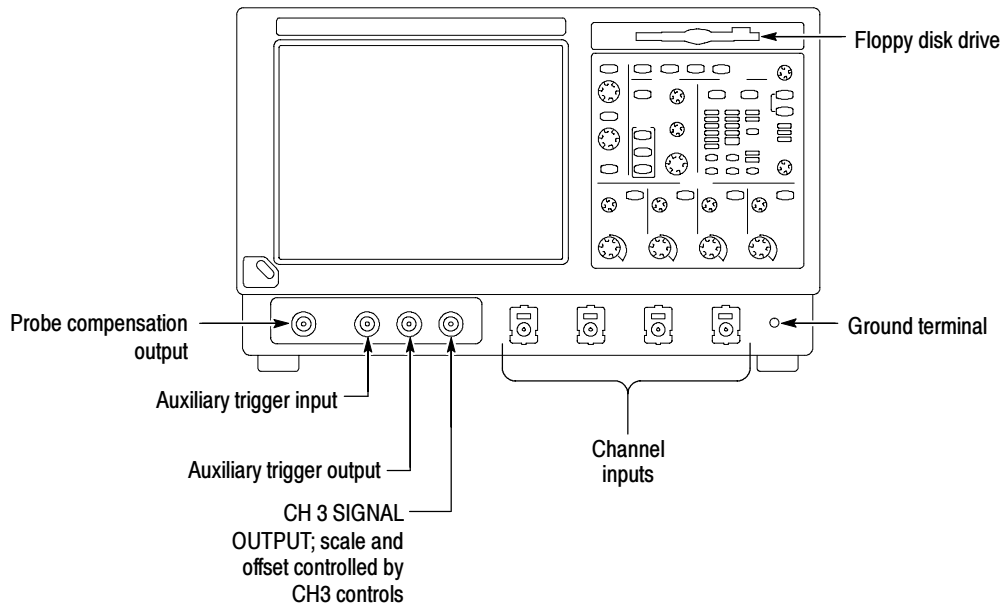

Instrument Diagnostics

Do the following steps to verify the instrument passes the internal diagnostics.

1. Display the diagnostics menu:
 - If the oscilloscope is in tool bar mode, touch the **MENU** button to put the oscilloscope into the menu bar mode.
 - Select **Instrument Diagnostics . . .** from the **Utilities** menu.
2. Run the diagnostics.
 - First disconnect any input signals from all four channels.
 - Touch the **Run** button in the diagnostics control window.
3. Wait for the diagnostics to complete.

The internal diagnostics do an exhaustive verification of proper oscilloscope function. This verification may take several minutes to complete. When the verification is finished, the resulting status will appear in the diagnostics control window.

4. Verify that no failures are found.

Signal Path Compensation

Run the Signal Path Compensation.

1. Select **Instrument Calibration . . .** from the **Utilities** menu.
2. Verify that the instrument has had a twenty-minute warm-up before continuing.
3. Touch the **Calibrate** button to start the routine.
4. Wait for the test to complete (the test may take several minutes to complete).
5. Verify that the word **Pass** appears under the Status label in the control window.

Using the Online Help

The user manual represents only part of the assistance available to you — the online help system, integrated as part of the oscilloscope user interface, provides quick-to-access support for operating this oscilloscope.

Two types of online help are available, the oscilloscope online help and the GPIB online programmer's help. The oscilloscope online help provides information on all of the oscilloscope controls and procedures for doing typical tasks. The GPIB online programmer's help is normally installed on a remote PC and provides information for controlling the oscilloscope via the GPIB. This section mainly discusses the online help for the oscilloscope.

Accessing Help in the Tool Bar Mode. When the oscilloscope is in the tool bar mode, touch the Help button in the upper right corner of the screen to display help on whatever control window is displayed. From within the Help window, you can access other help through tabs, links, or buttons. You can also touch the Help Topics button to display the standard Windows Contents, Index, and Find tabs.

Accessing Help in the Menu Bar Mode. When the oscilloscope is in the menu bar mode, you can access the help system from the drop-down help menu. Select Help on Window to display help on the current control window. Select Contents and Index to display the standard Windows Contents, Index, and Find tabs. You can also select other topics from the Help menu such as information on Technical Support or product specifications.

Moving the Help Topics to View the Oscilloscope Display. You may temporarily move any displayed help out of the way while you change control window settings. Touch the Minimize button in the help window to shrink the help window to a button that displays in the upper right corner of the display (with the label Restore Help). Touch the Restore Help button to restore the help window to its normal size.

Theory of Operation

This section describes the electrical operation of the oscilloscope. Figure 9-1 on page 9-2 shows the module interconnections.

Logic Conventions

The oscilloscope contains many digital logic circuits. This manual refers to these circuits with standard logic symbols and terms. Unless otherwise stated, all logic functions are described using the positive-logic convention: the more positive of the two logic levels is the high (1) state, and the more negative level is the low (0) state. Signal states may also be described as “true” meaning their active state or “false” meaning their nonactive state. The specific voltages that constitute a high or low state vary among the electronic devices.

Module Overviews

Module overviews describes the basic operation of each functional circuit block as shown in Figure 9-1 on page 9-2.

General

A dual-processor system controls the oscilloscope. The oscilloscope features a VGA resolution flat-panel display, a transparent touch screen, and a front-panel with direct access to commonly used oscilloscope functions. You can also use the oscilloscope with a mouse pointing device or keyboard.

Input Signal Path

A signal enters the oscilloscope through a direct coaxial connection to the input connector, or a probe connected to the front panel.

Acquisition Board. The acquisition board conditions the input signals, samples them, converts them to digital signals, and controls the acquisition process under direction of the processor system. The acquisition system includes the multi-source trigger, acquisition timebase, and acquisition mode generation and control circuitry. The acquisition board is located in the bottom compartment of the oscilloscope. Four vertical channels are accommodated. All channels feature a TekConnect interface for additional front-end signal conditioning functions.

Processor System. The processor system contains two processor boards with microprocessors that control the entire oscilloscope. The basic configuration supports four input channels labeled Ch1 through Ch 4, provides an external trigger input, a trigger output, a Ch3 signal output, and a probe compensation output.

Each acquisition channel is equipped with a processor that uses its own host interface to interface to the GCS which in turn communicates with the command interface processor over the multiplexed address/data nibble bus.

Display Panel Waveforms and menus are displayed on a 10.4 inch, color, active-matrix LCD display with touch panel.

Display System. Text and waveforms are processed by different parts of the display circuitry. The display system (display adapter board and inverter board) sends the text and waveform information to the display panel.

Touch Panel. The display board sends information from the touch panel to the processor. Any changes in settings are reported to the processor system.

Front Panel The NLX board reads the front-panel switches and encoders. Any changes in their settings are reported to the processor system. The NLX board also turns the LEDs on and off.

Menu Switches. Front-panel menu switches are also read by the NLX board. The touch screen processor sends any changes in menu selections to the NLX processor system. The **ON/STBY** switch passes through the CPU board to the NLX board. The NLX board creates the signal sent to the power supply to toggle power.

Floppy Drive. The floppy drive provides access to stored waveform data and software to customize your oscilloscope.

CPU Board. The CPU board provides fast access to the Acquisition board and the display system. The NLX board reads the front-panel switches and encoders and implements any changes requested by their settings. The CPU board provides a GPIB interface through a rear panel connector.

NLX Board. The NLX board provides standard Windows functionality and I/O port interfaces to the rear panel.

NLX Riser Board. Both processor systems, the floppy drive, CDROM-RW drive, and hard drive are connected together by, and communicate through, the riser board.

Rear Panel

The hard drive and CDROM-RW provide access to stored waveform data and software to customize your oscilloscope with your measurement needs. The GPIB allows for external control of the oscilloscope.

You can make hardcopies on the GPIB, RS-232, and Centronics ports. Other ports from the CPU board: PC cardbus x 2, and cal adjust lock.

The NLX board has one USB port and one serial port on the rear panel. The NLX has 2 USB channels, but one is used internally, routed to the riser board, and is not available for use. The NLX has one serial port, which is routed to the rear panel. A microphone input and earphone output exist on the NLX rear panel. Ethernet connector is RJ-45. Keyboard and mouse are both PS/2.

Low Voltage Power Supply

The low voltage power supply is a switching power converter with active power factor control. It supplies power to all of the circuitry in the oscilloscope.

The principal **POWER** switch, located on the rear panel, controls all power to the oscilloscope including the Low Voltage Power Supply. The **ON/STBY** switch, located on the front panel, also controls all of the power to the oscilloscope except for part of the circuitry in the standby power supply.

The power supply sends a power fail (~PF) warning to the processor system if the power is going down.

Power is distributed throughout the oscilloscope through the front and rear power distribution bus boards.

Fans

The fan assembly provides forced air cooling for the oscilloscope. The fans are controlled by the CPU and microprocessor.

Performance Verification

Two types of Performance Verification procedures can be performed on this product: *Brief Procedures* and *Performance Tests*. You may not need to perform all of these procedures, depending on what you want to accomplish.

- To rapidly confirm that the oscilloscope functions and was adjusted properly, just do the brief procedures under *Self Tests*, which begin on page 4-5.

Advantages: These procedures are quick to do, require no external equipment or signal sources, and perform extensive functional and accuracy testing to provide high confidence that the oscilloscope will perform properly. They can be used as a quick check before making a series of important measurements.

- To further check functionality, first do the *Self Tests* just mentioned; then do the brief procedures under *Functional Tests* that begin on page 4-6.

Advantages: These procedures require minimal additional time to perform, require no additional equipment other than a BNC cable and BNC-to-SMA adapter or a TCA-BNC adapter, and these procedures more completely test the internal hardware of the oscilloscope. They can be used to quickly determine if the oscilloscope is suitable for putting into service, such as when it is first received.

- If more extensive confirmation of performance is desired, do the *Performance Tests*, beginning on page 4-17, after doing the *Functional* and *Self Tests* mentioned above.

Advantages: These procedures add direct checking of the warranted specifications that are marked with the ✓ symbol. These procedures require specific test equipment. (See *Table 4-1: Test equipment* on page 4-18).

If you are not familiar with operating this oscilloscope, read the oscilloscope reference or user manuals or explore the online help.

Conventions

Throughout these procedures the following conventions apply:

- Each test procedure uses the following general format:

Title of Test

Equipment Required

Prerequisites

Procedure

- Each procedure consists of as many steps, substeps, and subparts as required to do the test. Steps, substeps, and subparts are sequenced as follows:

1. First Step

- a. First Substep

- First Subpart

- Second Subpart

- b. Second Substep

2. Second Step

- In steps and substeps, the lead-in statement in italics instructs you what to do, while the instructions that follow tell you how to do it, as in the example step below:

Initialize the oscilloscope: Push the front-panel **DEFAULT SETUP** button.

STOP. *The **STOP** notation at the left is accompanied by information you must read to do the procedure properly.*

- The term “toolbar” refers to a row of buttons at the top of the display. The term “menu bar” refers to a row of menus at the top of the display. You can switch between toolbar and menu bar operating modes by pushing the button near the top right corner of the display. See Figure 4-1.

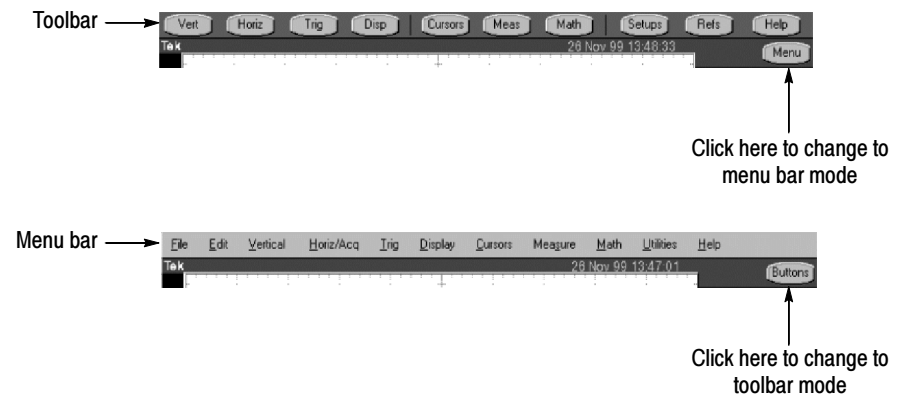

Figure 4-1: Toolbar and menu bar

- The procedures assume you have connected a mouse to the oscilloscope so you can click on the screen controls. If you have not connected a mouse, you can use the touch screen to operate all the screen controls.

Brief Procedures

The *Self Tests* use internal routines to confirm basic functionality and proper adjustment. No test equipment is required to do these test procedures.

The *Functional Tests* utilize the probe-compensation output at the front panel as a test-signal source for further verifying that the oscilloscope functions properly. A BNC cable and a BNC-to-SMA adaptor or a TCA-BNC adapter are required to do these test procedures.

Self Tests

This procedure uses internal routines to verify that the oscilloscope functions and was adjusted properly. No test equipment or hookups are required.

Verify Internal Adjustment, Self Compensation, and Diagnostics

Equipment required	None
Prerequisites	Power on the oscilloscope and allow a 20 minute warm-up before doing this procedure.

1. *Verify that internal diagnostics pass:* Do the following substeps to verify passing of internal diagnostics.
 - a. *Display the System diagnostics menu:*
 - If the oscilloscope is in toolbar mode, click the **MENU** button to put the oscilloscope into menu bar mode.
 - Pull down the **Utilities** menu and select **Instrument Diagnostics. . . .** This displays the diagnostics control window.
 - b. *Run the System Diagnostics:*
 - First disconnect any input signals from all four channels.
 - Click the **Run** button in the diagnostics control window.
 - c. *Wait:* The internal diagnostics do an exhaustive verification of proper oscilloscope function. This verification may take several minutes. When the verification is finished, the resulting status will appear in the diagnostics control window.

NOTE. *If diagnostic error message 531 is displayed, re-run signal-path compensation.*

- d. *Verify that no failures are found and reported on-screen. All tests should pass.*
 - e. *Run the signal-path compensation routine:*
 - Pull down the **Utilities** menu and select **Instrument Calibration**. . . This displays the instrument calibration control window.
 - If required because the oscilloscope is in service mode, select the **Signal Path** button under Calibration Area.
 - Click the **Calibrate** button to start the routine.
 - f. *Wait:* Signal-path compensation may take five to fifteen minutes to run.
 - g. *Confirm signal-path compensation returns passed status:* Verify that the word **Pass** appears in the instrument calibration control window.
2. *Return to regular service:* Click the **Close** button to exit the instrument calibration control window.

Functional Tests

The purpose of these procedures is to confirm that the oscilloscope functions properly. The only equipment required is a P7240 probe, a probe calibration and deskew fixture, a BNC cable, BNC-to-SMA adapter or TCA-BNC adapter, and, to check the file system, a 3.5 inch, 1.44 Mbyte, formatted floppy disk.

STOP. *These procedures verify functions that the oscilloscope features operate. They do not verify that they operate within limits.*

Therefore, when the instructions in the functional tests that follow call for you to verify that a signal appears on the screen “that is about five divisions in amplitude” or “has a period of about six horizontal divisions,” etc., do NOT interpret the quantities given as limits. Operation within limits is checked in Performance Tests, which begin on page 4-17.

STOP. Do not make changes to the front-panel settings that are not called out in the procedures. Each verification procedure will require you to set the oscilloscope to certain default settings before verifying functions. If you make changes to these settings, other than those called out in the procedure, you may obtain invalid results. In this case, just redo the procedure from step 1.

When you are instructed to press a front-panel or screen button, the button may already be selected (its label will be highlighted). If this is the case, it is not necessary to press the button.

Verify All Input Channels

Equipment required	One P7240 probe (TDS6404) or P7260 probe (TDS6604) One probe calibration and deskew fixture, Tektronix part number 067-0405-02 (TDS6404) or 067-0484-00 (TDS6604) One BNC cable, Tektronix part number 012-0076-00 or the cable 012-0208-00
Prerequisites	None

1. *Initialize the oscilloscope:* Push the front-panel **DEFAULT SETUP** button.
2. *Hook up the signal source:* Connect one end of the BNC cable to the PROBE COMPENSATION output connector in the oscilloscope. Connect the remaining end of the BNC cable to the GAIN CAL SIG connector of the fixture as shown in Figure 4-2 (TDS6604) on page 4-8 or Figure 4-3 (TDS6404) on page 4-9.
3. Install a P7240 (TDS6404) or TDS7260 (TDS6604) probe in the channel input you want to test (beginning with CH 1).
4. Connect the probe tip to the GAIN CAL pins on the fixture as shown in Figure 4-2 (TDS6604) on page 4-8 or Figure 4-3 (TDS6404) on page 4-9.

NOTE. If a P7240 or P7260 probe is not available, connect the probe compensation output to the channel input using a BNC cable and adapters.

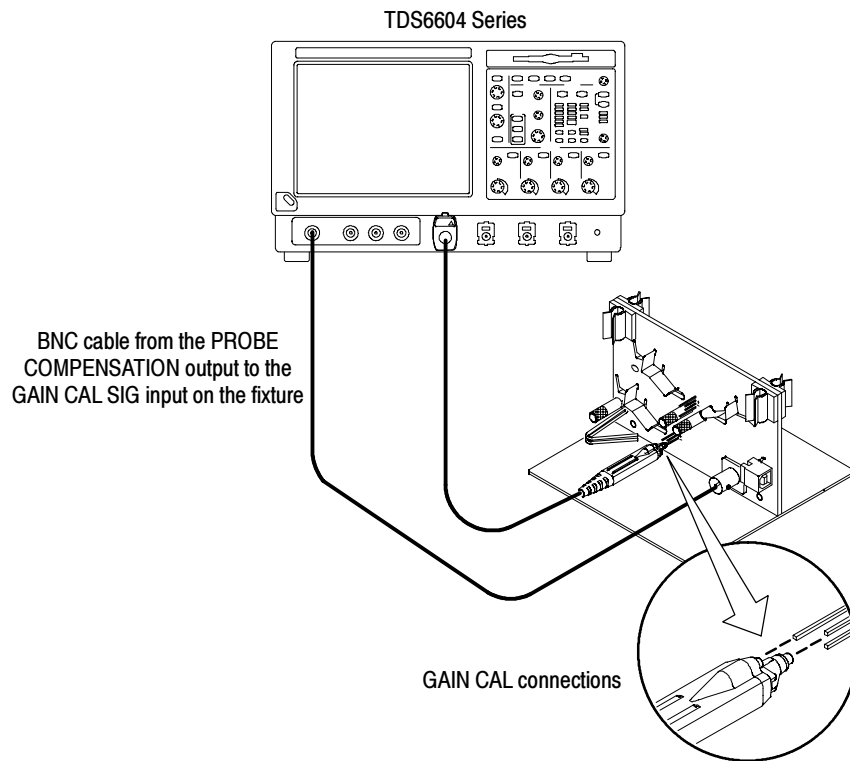

Figure 4-2: Universal test hookup for functional tests - CH 1 shown

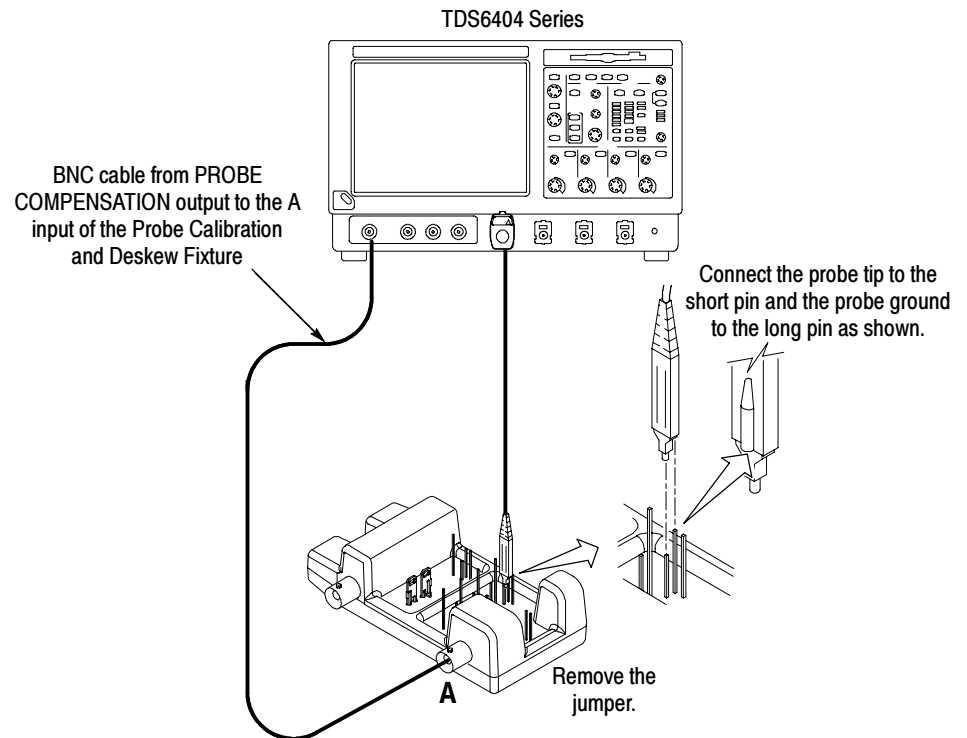

Figure 4-3: Universal test hookup for functional tests - CH 1 shown

5. *Turn off all channels:* If any of the front-panel channel buttons are lighted, push those buttons to turn off the displayed channels. See Figure 4-4.

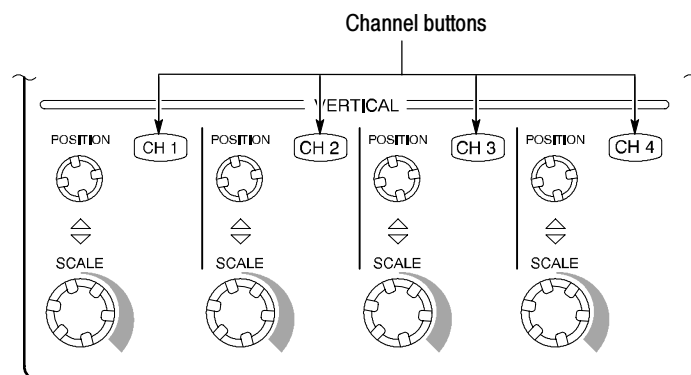

Figure 4-4: Channel button location

6. *Select the channel to test:* Push the channel button for the channel that you are currently testing. The button lights, and the channel display comes on.

7. *Set up the oscilloscope:*

- Push the front panel **AUTOSET** button. This sets the horizontal and vertical scale and vertical offset for a usable display and sets the trigger source to the channel that you are testing.
- Pull down the **Vert** menu, select **Vertical Setup**, and then touch **Offset**. Confirm that the Ch1 Offset is about **1.6 V** (0.0 V if not using a P7240 or P7260 probe).

8. *Verify that the channel is operational:* Confirm that the following statements are true.

- For TDS6604: The vertical scale readout for the channel under test shows a setting of about 500 mV, and a square-wave probe-compensation signal about 1 division (0.5 divisions if not using a probe) in amplitude (about 460 mV [240 mV if not using a P7260 probe]) is on the screen.
- For TDS6404: The vertical scale readout for the channel under test shows a setting of about 200 mV (500 mV if not using a P7240 probe), and a square wave probe-compensation signal about 2.2 divisions (0.5 divisions if not using a probe) in amplitude (about 448 mV [240 mV if not using a P7240 probe]) is on the screen.
- The front-panel vertical **POSITION** knob (for the channel that you are testing) moves the signal up and down the screen when rotated.
- Turning the vertical **SCALE** knob counterclockwise (for the channel you are testing) decreases the amplitude of the waveform on-screen, turning the knob clockwise increases the amplitude, and returning the knob to 100 mV (500 mV if not using a probe) returns the amplitude to about 4.5 divisions (0.5 divisions if not using a probe).

9. *Verify that the channel acquires in all acquisition modes:* Pull down the Horiz/Acq menu to select **Horizontal/Acquisition Setup**. . . . Click the **Acquisition** tab in the control window that displays. Click each of the six acquisition modes and confirm that the following statements are true.

- Sample mode displays an actively acquiring waveform on-screen. (Note that there is a small amount of noise present on the square wave).
- Peak Detect mode displays an actively acquiring waveform on the screen with the noise present in Sample mode “peak detected.”
- Hi Res mode displays an actively acquiring waveform on the screen with the noise that was present in Sample mode reduced.
- Average mode displays an actively acquiring waveform on the screen with the noise reduced.

- Envelope mode displays an actively acquiring waveform on the screen with the noise displayed.
 - Waveform Database or WfmDB mode displays an actively acquiring and displays a waveform that is the accumulation of several acquisitions.
10. *Test all channels:* Repeat steps 2 through 9 until all four input channels are verified.
 11. *Remove the test hookup:* Disconnect the BNC cable, fixture, and the probe from the channel input and the probe compensation output.

Verify the Time Base

Equipment required	One BNC cable, such as Tektronix part number 012-0076-00 One TCA-BNC adapter
Prerequisites	None

1. *Initialize the oscilloscope:* Push the front-panel **DEFAULT SETUP** button.
2. *Hook up the signal source:* Connect the BNC cable from the probe compensation output to the CH 1 input through a TCA-BNC adapter as shown in Figure 4-5.

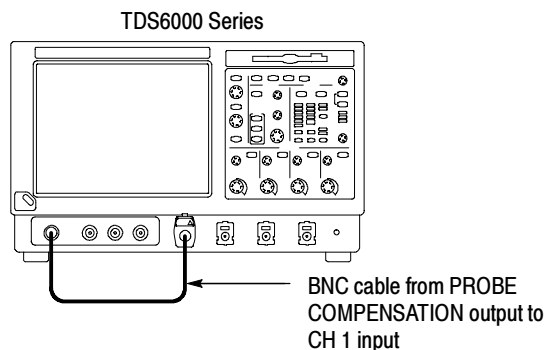

Figure 4-5: Setup for time base test

3. *Set up the oscilloscope:* Push the front panel **AUTOSET** button.
4. Pull down the **Vert** menu, select Vertical Setup, and then touch **Offset**. Adjust the Ch1 Offset to approximately **0.8 V** using the multipurpose knob.
5. Set the **Vertical SCALE** to **100 mV** per division.
6. *Set the time base:* Set the horizontal **SCALE** to **200 μ s/div**. The time-base readout is displayed at the bottom of the graticule.
7. *Verify that the time base operates:* Confirm the following statements.

- One period of the square-wave probe-compensation signal is about five horizontal divisions on-screen for the 200 $\mu\text{s}/\text{div}$ horizontal scale setting.
 - Rotating the horizontal **SCALE** knob clockwise expands the waveform on the screen (more horizontal divisions per waveform period), counterclockwise rotation contracts it, and returning the horizontal scale to 200 $\mu\text{s}/\text{div}$ returns the period to about five divisions.
 - The horizontal **POSITION** knob positions the signal left and right on the screen when rotated.
8. *Verify horizontal delay:*
- a. *Center a rising edge on screen:*
 - Set the horizontal **POSITION** knob so that the rising edge where the waveform is triggered is lined up with the center horizontal graticule.
 - Change the horizontal **SCALE** to **20 $\mu\text{s}/\text{div}$** . The rising edge of the waveform should remain near the center graticule and the falling edge should be off screen.
 - b. *Turn on and set horizontal delay:*
 - Pull down the Horiz/Acq menu to select **Horizontal/Acquisition Setup. . . .**
 - Click the **Horizontal** tab in the control window that displays.
 - Click the **Delay Mode** button to turn delay on.
 - Double click the **Horiz Delay** control in the control window to display the pop-up keypad. Click the keypad buttons to set the horizontal delay to **500 μs** , and then click the **ENTER** key.
 - c. *Verify the waveform:* Verify that a falling edge of the waveform is within a few divisions of center screen.
 - d. *Adjust the horizontal delay:* Rotate the upper multipurpose knob to change the horizontal delay setting. Verify that the falling edge shifts horizontally. Rotate the front-panel horizontal **POSITION** knob. Verify that this knob has the same effect (it also adjusts delay, but only when delay mode is on).
 - e. *Verify the delay toggle function:*
 - Rotate the front-panel horizontal **POSITION** knob to center the falling edge horizontally on the screen.

- Change the horizontal **SCALE** to **40 ns/div**. The falling edge of the waveform should remain near the center graticule. If not, readjust the delay setting to center the falling edge.
 - Push the front-panel **DELAY** button several times to toggle delay off and on and back off again. Verify that the display switches quickly between two different points in time (the rising and falling edges of this signal).
9. *Remove the test hookup:* Disconnect the BNC cable from the channel input and the probe compensation output.

Verify the A (Main) and B (Delayed) Trigger Systems

Equipment required	One BNC cable, such as Tektronix part number 012-0076-00 One TCA-BNC adapter
Prerequisites	None

1. *Initialize the oscilloscope:* Push the front-panel **DEFAULT SETUP** button.
2. *Hook up the signal source:* Connect the BNC cable from the probe compensation output to the CH 1 input through a TCA-BNC adapter as shown in Figure 4-6.

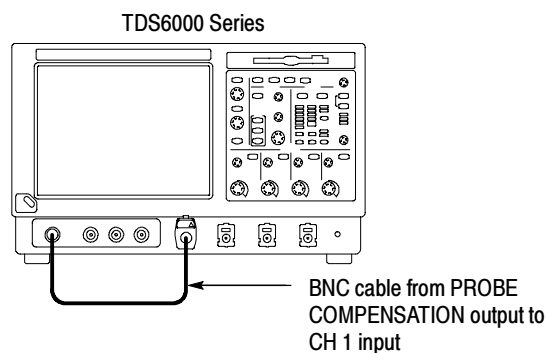

Figure 4-6: Setup for trigger test

3. *Set up the oscilloscope:* Push the front-panel **AUTOSET** button.
4. Pull down the **Vert** menu, select Vertical Setup, and then touch **Offset**. Adjust the Ch1 Offset to approximately **0.8 V** using the multipurpose knob.
5. Set the **Vertical SCALE** to **100 mV** per division.

6. *Verify that the main trigger system operates:* Confirm that the following statements are true:
 - The trigger level readout for the A (main) trigger system changes with the trigger-LEVEL knob.
 - The trigger-LEVEL knob can trigger and untrigger the square-wave signal as you rotate it. (Leave the signal untriggered).
 - Pushing the front-panel trigger LEVEL knob sets the trigger level to the 50% amplitude point of the signal and triggers the signal that you just left untriggered. (Leave the signal triggered.)
7. *Verify that the delayed trigger system operates:*
 - a. *Set up the delayed trigger:*
 - Pull down the **Trig** menu and select **A — B Trigger Sequence. . . .** This displays the A→B Sequence tab of the trigger setup control window.
 - Click the **Trig After Time** button under A Then B.
 - Click the **B Trig Level** control in the control window.
 - b. *Confirm that the following statements are true:*
 - The trigger-level readout for the B trigger system changes as you turn the lower multipurpose knob.
 - As you rotate the lower multipurpose knob, the square-wave probe-compensation signal can become triggered and untriggered. (Leave the signal triggered.)
 - c. *Verify the delayed trigger counter:*
 - Double click the **Trig Delay** control to pop up a numeric keypad for that control.
 - Click the keypad to enter a trigger delay time of 1 second and then click **Enter**.
 - Verify that the trigger READY indicator on the front panel flashes about once every second as the waveform is updated on-screen.
8. *Remove the test hookup:* Disconnect the BNC cable from the channel input and the probe compensation output.

Verify the File System

Equipment required	One BNC cable, such as Tektronix part number 012-0076-00 One TCA-BNC adapter One 1.44 Mbyte, 3.5 inch DOS-compatible formatted disk.
Prerequisites	None

1. *Initialize the oscilloscope:* Push the front-panel **DEFAULT SETUP** button.
2. *Hook up the signal source:* Connect the BNC cable from the probe compensation output to the CH 1 input through a TCA-BNC adapter as shown in Figure 4-7.

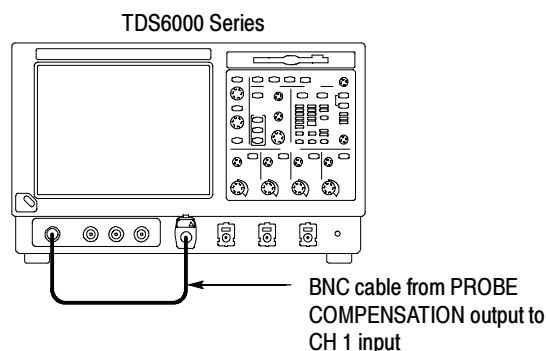
**Figure 4-7: Setup for the file system test**

3. *Insert the test disk:* Insert the floppy disk in the floppy disk drive at the top of the front panel.
4. *Set up the oscilloscope:* Push the front panel **AUTOSET** button.
5. Pull down the **Vert** menu, select Vertical Setup, and then touch **Offset**. Adjust the Ch1 Offset to approximately **0.8 V** using the multipurpose knob.
6. Set the **Vertical SCALE** to **100 mV** per division.
7. *Set the time base:* Set the horizontal **SCALE** to **1 ms/div**. The time-base readout is displayed at the bottom of the graticule.
8. *Save the settings:*
 - a. Pull down the **File** menu to select **Instrument Setup**. . . . This displays the instrument setups control window.
 - b. Click the **Save** button under Save settings to file in the control window. This displays a familiar Windows dialog box for choosing a destination directory naming the file.

- c. In the Save Instrument Setups As dialog box, select the **3¹/₂ Floppy (A:)** icon in the Save in: drop-down list to set the save destination to the floppy disk.
 - d. Note the default file name, and then click the **Save** button to save the setup to the default file name.
9. *Change the settings again:* Set the horizontal **SCALE** to **200 μ s/div**.
10. *Verify the file system works:*
 - a. Click the **Recall Setups** tab in the control window.
 - b. Click the **Recall** button under Recall settings from file in the control window. This displays a familiar Windows dialog box for locating the settings file that you want to recall.
 - c. In the Recall Save Instrument Setups From dialog box, select the **3¹/₂ Floppy (A:)** icon in the Look in: drop-down list.
 - d. Locate and then double click in the dialog box on the setup file that you previously stored.
 - e. Verify that the oscilloscope retrieved the saved setup from the disk. Do this by noticing that the horizontal **SCALE** is again 1 ms and the waveform shows ten cycles just as it did when you saved the setup.
11. *Remove the test hookup:*
 - a. Disconnect the BNC cable and adapter from the channel input and the probe compensation output.
 - b. Remove the floppy disk from the floppy disk drive.

Performance Tests

This section contains a collection of manual procedures for checking that the TDS6000 Series oscilloscope performs as warranted.

The procedures are arranged in four logical groupings: *Signal Acquisition System Checks*, *Time Base System Checks*, *Triggering System Checks*, and *Output Ports Checks*. They check all the characteristics that are designated as checked in *Specifications*. (The characteristics that are checked appear with a ✓ in *Specifications*).

STOP. *These procedures extend the confidence level provided by the basic procedures described on page 4-5. The basic procedures should be done first, then these procedures performed if desired.*

Prerequisites

The tests in this section comprise an extensive, valid confirmation of performance and functionality when the following requirements are met:

- The cabinet must be installed on the oscilloscope.
- You must have performed and passed the procedures under *Self Tests*, found on page 4-5, and those under *Functional Tests*, found on page 4-6.
- A signal-path compensation must have been done within the recommended calibration interval and at a temperature within ± 5 °C of the present operating temperature. A signal-path compensation must have been done at an ambient humidity within 25% of the current ambient humidity and after having been at that humidity for at least 4 hours.
- The oscilloscope must have been last adjusted at an ambient temperature between +20 °C and +30 °C, must have been operating for a warm-up period of at least 20 minutes, and must be operating at an ambient temperature as listed in Table 1-11. (The warm-up requirement is usually met in the course of meeting the Self Tests and Functional Tests prerequisites listed above).

Equipment Required

Procedures starting on page 4-29, use external, traceable signal sources to directly check warranted characteristics. Table 4-1 lists the required equipment.

Table 4-1: Test equipment

Item number and description	Minimum requirements	Example	Purpose
1. Attenuator, 10X (two required)	Ratio: 10X; impedance 50 Ω ; connectors: female BNC input, male BNC output	Tektronix part number 011-0059-02	Signal Attenuation
2. Attenuator, 5X	Ratio: 5X; impedance 50 Ω ; connectors: female BNC input, male BNC output	Tektronix part number 011-0060-02	Signal Attenuation
3. Terminator, 50 Ω (three required)	Impedance 50 Ω ; connectors: female BNC input, male BNC output	Tektronix part number 011-0049-01	Signal Termination for Channel Delay Test
4. Cable, Precision 50 Ω Coaxial (three required)	50 Ω , 36 in, male-to-male BNC connectors	Tektronix part number 012-0482-00	Signal Interconnection
5. Connector, Dual-Banana (two required)	Female BNC-to-dual banana	Tektronix part number 103-0090-00	Various Accuracy Tests
6. Connector, BNC "T"	Male BNC-to-dual female BNC	Tektronix part number 103-0030-00	Checking Trigger Sensitivity
7. Probe, 10X	P7240 probe (TDS6404) P7260 probe (TDS6604)	Tektronix part number P7240 Tektronix part number P7260	Signal Interconnection
8. Floppy disk	3.5 inch 1.44 Mbyte, DOS-compatible floppy disk	Standard IBM PC-compatible disk	Checking File System Basic Functionality
9. Generator, DC Calibration	Variable amplitude to ± 7 V; accuracy to 0.1%	Wavetek 9500 ¹	Checking DC Offset, Gain, Measurement Accuracy, and Maximum Input Voltage
10. Generator, Calibration	500 mV square wave calibrator amplitude; accuracy to 0.25%	Wavetek 9500 ¹	To check accuracy of Signal Out
11. Timer-counter	25 MHz, 1 s gate	Advantest R5360	Checking long-term sample rate and delay time accuracy
12. Generator, Sine-Wave ³	5 kHz to at least 6 GHz. Variable amplitude from 60 mV to 2 V _{p-p} into 50 Ω . Frequency error <2.0%	Rohde & Schwarz SMT06 with options 01 and 02	Checking Analog Bandwidth, Trigger Sensitivity, Sample-rate, External Clock, and Delay-Time Accuracy
13. Meter, Level and Power Sensor	Frequency range: 10 MHz to the oscilloscope bandwidth. Amplitude range: 6 mV _{p-p} to 2 V _{p-p}	Rohde & Schwarz NRVS and NRV-Z402	Checking Analog Bandwidth and Trigger Sensitivity
14. Splitter, Power	Frequency range: DC to 4 GHz. Tracking: >2.0%	Tektronix part number 015-0565-00	Checking Analog Bandwidth

Table 4-1: Test equipment (Cont.)

Item number and description	Minimum requirements	Example	Purpose
15. Adapter (four required)	Male N-to-female BNC	Tektronix part number 103-0045-00	Checking Analog Bandwidth
16. Adapter	Female N-to-male BNC	Tektronix part number 103-0058-00	Checking Analog Bandwidth
17. Adapter (three required)	SMA female-to-female	Tektronix part number 015-1012-00	Checking the delay between channels
18. Adapter (three required)	SMA male-to-female BNC	Tektronix part number 015-1018-00	Checking the delay between channels
19. Adapter (four required)	SMA male-to-BNC female	TCA-BNC or TCA-SMA and SMA male-to-BNC female adapter (Tektronix part number 015-0554-00 or 015-1018-00)	Signal interconnection
20. Pulse Generator	2 MHz, ≤ 150 ps rise time, 5 V out	Fluke 9500 ^{1,2}	Used to Test Delta Time Measurement Accuracy
21. Cable, Coaxial (two required)	50 Ω , 20 in, male-to-male SMA connectors	Tektronix part number 174-1427-00	Used to Test Delta Time Measurement Accuracy
22. Adapter	SMA "T", male to 2 SMA female	Tektronix part number 015-1016-00	Used to Test Delta Time Measurement Accuracy
23. Adapter	SMA female to BNC male	Tektronix part number 015-0572-00	Used to Test Delta Time Measurement Accuracy
24. Adapter	BNC male to female elbow	Tektronix part number 103-0031-00	Used to Test Delta Time Measurement Accuracy
25. Terminator	Short circuit, SMA connector	Tektronix part number 015-1021-00	Used to Test Delta Time Measurement Accuracy
26. Attenuator, 2X	Ratio: 2X; impedance 50 Ω ; connectors: female BNC input, male BNC output	Tektronix part number 011-0069-02	Used to Test Delta Time Measurement Accuracy
27. Digital Multimeter	Ohms: <60 Ohms	Keithley 2000	Checking input impedance

¹ Fluke 9500 with option 100 and an output head (9520, 9530, or 9550) appropriate for the bandwidth of the oscilloscope being tested.

² For Delta Time Measurement Accuracy, use a Fluke 9500 or a pulse generator with a rise time as shown in Table 4-7 on page 4-62.

³ On Instruments with a bandwidth ≤ 3 GHz, items 12, 13, and 14 may be replaced with a Fluke 9500 with option 100 and a 9559 output head.

TDS6000 Test Records

Photocopy the following table and use it to record the performance test results for your TDS6000 Digital Storage Oscilloscope.

TDS6000 Test Record

Clock recovery frequency range		Pass	_____	_____	N/A
Instrument Serial Number: _____		Certificate Number: _____			
Temperature: _____		RH %: _____			
Date of Calibration: _____		Technician: _____			
TDS6000 performance test		Minimum	Incoming	Outgoing	Maximum
DC voltage measurement accuracy (averaged)					
CH1	50 mV Vert scale setting, -5 Div position setting, +0.5 V offset	+ 883.50 mV	_____	_____	+ 916.50 mV
CH1	50 mV Vert scale setting, +5 Div position setting, -0.5 V offset	- 916.50 V	_____	_____	- 883.50 mV
CH1	100 mV Vert scale setting, -5 Div position setting, +5 V offset	+ 5.45 V	_____	_____	+ 5.55 V
CH1	100 mV Vert scale setting, +5 Div position setting, -5 V offset	- 5.55 V	_____	_____	- 5.45 V
CH1	1.0 V Vert scale setting, -5 Div position setting, +2.5 V offset	+ 4.20 V	_____	_____	+ 4.80 V
CH1	1.0 V Vert scale setting, +5 Div position setting, -2.5 V offset	- 4.80 V	_____	_____	- 4.20 V
CH2	50 mV Vert scale setting, -5 Div position setting, +0.5 V offset	+ 883.50 mV	_____	_____	+ 916.50 mV
CH2	50 mV Vert scale setting, +5 Div position setting, -0.5 V offset	- 916.50 V	_____	_____	- 883.50 mV
CH2	100 mV Vert scale setting, -5 Div position setting, +5 V offset	+ 5.45 V	_____	_____	+ 5.55 V
CH2	100 mV Vert scale setting, +5 Div position setting, -5 V offset	- 5.55 V	_____	_____	- 5.45 V
CH2	1.0 V Vert scale setting, -5 Div position setting, +2.5 V offset	+ 4.20 V	_____	_____	+ 4.80 V
CH2	1.0 V Vert scale setting, +5 Div position setting, -2.5 V offset	- 4.80 V	_____	_____	- 4.20 V

TDS6000 Test Record (cont.)

Instrument Serial Number: _____ Certificate Number: _____
 Temperature: _____ RH %: _____
 Date of Calibration: _____ Technician: _____

TDS6000 performance test		Minimum	Incoming	Outgoing	Maximum
CH3	50 mV Vert scale setting, -5 Div position setting, +0.5 V offset	+ 883.50 mV	_____	_____	+ 916.50 mV
CH3	50 mV Vert scale setting, +5 Div position setting, -0.5 V offset	- 916.50 V	_____	_____	- 883.50 mV
CH3	100 mV Vert scale setting, -5 Div position setting, +5 V offset	+ 5.45 V	_____	_____	+ 5.55 V
CH3	100 mV Vert scale setting, +5 Div position setting, -5 V offset	- 5.55 V	_____	_____	- 5.45 V
CH3	1.0 V Vert scale setting, -5 Div position setting, +2.5 V offset	+ 4.20 V	_____	_____	+ 4.80 V
CH3	1.0 V Vert scale setting, +5 Div position setting, -2.5 V offset	- 4.80 V	_____	_____	- 4.20 V
CH4	50 mV Vert scale setting, -5 Div position setting, +0.5 V offset	+ 883.50 mV	_____	_____	+ 916.50 mV
CH4	50 mV Vert scale setting, +5 Div position setting, -0.5 V offset	- 916.50 V	_____	_____	- 883.50 mV
CH4	100 mV Vert scale setting, -5 Div position setting, +5 V offset	+ 5.45 V	_____	_____	+ 5.55 V
CH4	100 mV Vert scale setting, +5 Div position setting, -5 V offset	- 5.55 V	_____	_____	- 5.45 V
CH4	1.0 V Vert scale setting, -5 Div position setting, +2.5 V offset	+ 4.20 V	_____	_____	+ 4.80 V
CH4	1.0 V Vert scale setting, +5 Div position setting, -2.5 V offset	- 4.80 V	_____	_____	- 4.20 V

TDS6000 Test Record (cont.)

Instrument Serial Number: _____ Certificate Number: _____
 Temperature: _____ RH %: _____
 Date of Calibration: _____ Technician: _____

TDS6000 performance test		Minimum	Incoming	Outgoing	Maximum
Offset accuracy					
CH1	50 mV Vert scale setting, +0.5 V offset 0 V offset -0.5 V offset	+ 491.75 mV - 6.5 mV - 508.25 mV	_____ _____ _____	_____ _____ _____	+ 508.25 mV + 6.5 mV - 491.75 mV
CH1	100 mV Vert scale setting, +5 V offset 0 V offset -5 V offset	+ 4.9575 V - 25 mV - 5.0425 V	_____ _____ _____	_____ _____ _____	+ 5.0425 V + 25 mV - 4.9575 V
CH1	500 mV Vert scale setting, +5 V offset 0 V offset -5 V offset	+ 4.9175 V - 65 mV - 5.0825 V	_____ _____ _____	_____ _____ _____	+ 5.0825 V + 65 mV - 4.9175 V
CH1	1.0 V Vert scale setting, +2.5 V offset 0 V offset -2.5 V offset	+ 2.37625 V - 115 mV - 2.62375 V	_____ _____ _____	_____ _____ _____	+ 2.62375 V + 115 mV - 2.37625 V
CH2	50 mV Vert scale setting, +0.5 V offset 0 V offset -0.5 V offset	+ 491.75 mV - 6.5 mV - 508.25 mV	_____ _____ _____	_____ _____ _____	+ 508.25 mV + 6.5 mV - 491.75 mV
CH2	100 mV Vert scale setting, +5 V offset 0 V offset -5 V offset	+ 4.9575 V - 25 mV - 5.0425 V	_____ _____ _____	_____ _____ _____	+ 5.0425 V + 25 mV - 4.9575 V
CH2	500 mV Vert scale setting, +5 V offset 0 V offset -5 V offset	+ 4.9175 V - 65 mV - 5.0825 V	_____ _____ _____	_____ _____ _____	+ 5.0825 V + 65 mV - 4.9175 V
CH2	1.0 V Vert scale setting, +2.5 V offset 0 V offset -2.5 V offset	+ 2.37625 V - 115 mV - 2.62375 V	_____ _____ _____	_____ _____ _____	+ 2.62375 V + 115 mV - 2.37625 V

TDS6000 Test Record (cont.)

Instrument Serial Number: _____ Certificate Number: _____
 Temperature: _____ RH %: _____
 Date of Calibration: _____ Technician: _____

TDS6000 performance test		Minimum	Incoming	Outgoing	Maximum
CH3	50 mV Vert scale setting, +0.5 V offset 0 V offset -0.5 V offset	+ 491.75 mV - 6.5 mV - 508.25 mV	_____ _____ _____	_____ _____ _____	+ 508.25 mV + 6.5 mV - 491.75 mV
CH3	100 mV Vert scale setting, +5 V offset 0 V offset -5 V offset	+ 4.9575 V - 25 mV - 5.0425 V	_____ _____ _____	_____ _____ _____	+ 5.0425 V + 25 mV - 4.9575 V
CH3	500 mV Vert scale setting, +5 V offset 0 V offset -5 V offset	+ 4.9175 V - 65 mV - 5.0825 V	_____ _____ _____	_____ _____ _____	+ 5.0825 V + 65 mV - 4.9175 V
CH3	1.0 V Vert scale setting, +2.5 V offset 0 V offset -2.5 V offset	+ 2.37625 V - 115 mV - 2.62375 V	_____ _____ _____	_____ _____ _____	+ 2.62375 V + 115 mV - 2.37625 V
CH4	50 mV Vert scale setting, +0.5 V offset 0 V offset -0.5 V offset	+ 491.75 mV - 6.5 mV - 508.25 mV	_____ _____ _____	_____ _____ _____	+ 508.25 mV + 6.5 mV - 491.75 mV
CH4	100 mV Vert scale setting, +5 V offset 0 V offset -5 V offset	+ 4.9575 V - 25 mV - 5.0425 V	_____ _____ _____	_____ _____ _____	+ 5.0425 V + 25 mV - 4.9575 V
CH4	500 mV Vert scale setting, +5 V offset 0 V offset -5 V offset	+ 4.9175 V - 65 mV - 5.0825 V	_____ _____ _____	_____ _____ _____	+ 5.0825 V + 65 mV - 4.9175 V
CH4	1.0 V Vert scale setting, +2.5 V offset 0 V offset -2.5 V offset	+ 2.37625 V - 115 mV - 2.62375 V	_____ _____ _____	_____ _____ _____	+ 2.62375 V + 115 mV - 2.37625 V

TDS6000 Test Record (cont.)

Instrument Serial Number: _____ Certificate Number: _____
 Temperature: _____ RH %: _____
 Date of Calibration: _____ Technician: _____

TDS6000 performance test		Minimum	Incoming	Outgoing	Maximum
Analog bandwidth					
CH1	1 V	3.535 V	_____	_____	N/A
	500 mV	2.12 V	_____	_____	N/A
	200 mV	848 mV	_____	_____	N/A
	100 mV	424 mV	_____	_____	N/A
	50 mV	212 mV	_____	_____	N/A
	20 mV	84.8 mV	_____	_____	N/A
	10 mV	42.4 mV	_____	_____	N/A
CH2	1 V	3.535 V	_____	_____	N/A
	500 mV	2.12 V	_____	_____	N/A
	200 mV	848 V	_____	_____	N/A
	100 mV	424 mV	_____	_____	N/A
	50 mV	212 mV	_____	_____	N/A
	20 mV	84.8 mV	_____	_____	N/A
	10 mV	42.4 mV	_____	_____	N/A
CH3	1 V	3.535 V	_____	_____	N/A
	500 mV	2.12 V	_____	_____	N/A
	200 mV	848 V	_____	_____	N/A
	100 mV	424 mV	_____	_____	N/A
	50 mV	212 mV	_____	_____	N/A
	20 mV	84.8 mV	_____	_____	N/A
	10 mV	42.4 mV	_____	_____	N/A
CH4	1 V	3.535 V	_____	_____	N/A
	500 mV	2.12 V	_____	_____	N/A
	200 mV	848 V	_____	_____	N/A
	100 mV	424 mV	_____	_____	N/A
	50 mV	212 mV	_____	_____	N/A
	20 mV	84.8 mV	_____	_____	N/A
	10 mV	42.4 mV	_____	_____	N/A

TDS6000 Test Record (cont.)

Instrument Serial Number: _____ Certificate Number: _____
 Temperature: _____ RH %: _____
 Date of Calibration: _____ Technician: _____

TDS6000 performance test	Minimum	Incoming	Outgoing	Maximum
Delay between channels	N/A	_____	_____	30 ps
Channel isolation 1.5 GHz				
100 mV				
CH 1	N/A	_____	_____	0.125 divisions
CH 2	N/A	_____	_____	0.125 divisions
CH 3	N/A	_____	_____	0.125 divisions
CH 4	N/A	_____	_____	0.125 divisions
50 mV				
CH 1	N/A	_____	_____	0.125 divisions
CH 2	N/A	_____	_____	0.125 divisions
CH 3	N/A	_____	_____	0.125 divisions
CH 4	N/A	_____	_____	0.125 divisions
10 mV				
CH 1	N/A	_____	_____	0.125 divisions
CH 2	N/A	_____	_____	0.125 divisions
CH 3	N/A	_____	_____	0.125 divisions
CH 4	N/A	_____	_____	0.125 divisions
full bandwidth				
100 mV				
CH 1	N/A	_____	_____	0.5 divisions
CH 2	N/A	_____	_____	0.5 divisions
CH 3	N/A	_____	_____	0.5 divisions
CH 4	N/A	_____	_____	0.5 divisions
50 mV				
CH 1	N/A	_____	_____	0.5 divisions
CH 2	N/A	_____	_____	0.5 divisions
CH 3	N/A	_____	_____	0.5 divisions
CH 4	N/A	_____	_____	0.5 divisions
10 mV				
CH 1	N/A	_____	_____	0.5 divisions
CH 2	N/A	_____	_____	0.5 divisions
CH 3	N/A	_____	_____	0.5 divisions
CH 4	N/A	_____	_____	0.5 divisions
Input impedance				
CH1 10 mV	48.75 Ω	_____	_____	51.25 Ω
CH1 100 mV	48.75 Ω	_____	_____	51.25 Ω
CH2 10 mV	48.75 Ω	_____	_____	51.25 Ω
CH2 100 mV	48.75 Ω	_____	_____	51.25 Ω
CH3 10 mV	48.75 Ω	_____	_____	51.25 Ω
CH3 100 mV	48.75 Ω	_____	_____	51.25 Ω
CH4 10 mV	48.75 Ω	_____	_____	51.25 Ω
CH4 100 mV	48.75 Ω	_____	_____	51.25 Ω

TDS6000 Test Record (cont.)

Instrument Serial Number: _____ Certificate Number: _____
 Temperature: _____ RH %: _____
 Date of Calibration: _____ Technician: _____

TDS6000 performance test		Minimum	Incoming	Outgoing	Maximum
Time base system					
Long term sample rate, delay time, and internal reference accuracy		9999.975 kHz	_____	_____	10000.025 kHz
Delta time measurement	Ch 1	N/A	_____	_____	≤ 0.015 ns
	Ch 2	N/A	_____	_____	≤ 0.015 ns
	Ch 3	N/A	_____	_____	≤ 0.015 ns
	Ch 4	N/A	_____	_____	≤ 0.015 ns
Trigger system accuracy					
Time accuracy for pulse, glitch, timeout, and Width, Hor. scale ≤ 1 μs					
	Lower Limit	3.5 ns	_____	_____	6.5 ns
	Upper Limit	3.5 ns	_____	_____	6.5 ns
Time accuracy for pulse, glitch, timeout, and width, Hor. scale > 1 μs					
	Lower Limit	1.9 μs	_____	_____	2.1 μs
	Upper Limit	1.9 μs	_____	_____	2.1 μs
Probe compensation output signal					
Frequency		950 Hz	_____	_____	1.050 kHz
Voltage (difference)		160 mV	_____	_____	240 mV

TDS6000 Test Record (cont.)

Instrument Serial Number: _____ Certificate Number: _____
 Temperature: _____ RH %: _____
 Date of Calibration: _____ Technician: _____

TDS6000 performance test	Minimum	Incoming	Outgoing	Maximum
Serial trigger (Option ST only)				
Baud rate limits				
Serial word recognizer				
Signal path 0, Pattern matching 1				
Trigger 1 UI before 0	Pass	_____	_____	N/A
Trigger on 0	Pass	_____	_____	N/A
Trigger 1 UI after 0	Pass	_____	_____	N/A
Signal path 1, Pattern matching 1				
Trigger 1 UI before 1	Pass	_____	_____	N/A
Trigger on 1	Pass	_____	_____	N/A
Trigger 1 UI after 1	Pass	_____	_____	N/A
Pattern matching 0				
Position 1	Pass	_____	_____	N/A
Position 2	Pass	_____	_____	N/A
Position 3	Pass	_____	_____	N/A
Position 4	Pass	_____	_____	N/A
Position 5	Pass	_____	_____	N/A
Position 6	Pass	_____	_____	N/A
Position 7	Pass	_____	_____	N/A
Position 8	Pass	_____	_____	N/A
Position 9	Pass	_____	_____	N/A
Position 10	Pass	_____	_____	N/A
Position 11	Pass	_____	_____	N/A
Position 12	Pass	_____	_____	N/A
Position 13	Pass	_____	_____	N/A
Position 14	Pass	_____	_____	N/A
Position 15	Pass	_____	_____	N/A
Position 16	Pass	_____	_____	N/A
Position 17	Pass	_____	_____	N/A
Position 18	Pass	_____	_____	N/A
Position 19	Pass	_____	_____	N/A
Position 20	Pass	_____	_____	N/A
Position 21	Pass	_____	_____	N/A
Position 22	Pass	_____	_____	N/A
Position 23	Pass	_____	_____	N/A
Position 24	Pass	_____	_____	N/A
Position 25	Pass	_____	_____	N/A
Position 26	Pass	_____	_____	N/A
Position 27	Pass	_____	_____	N/A
Position 28	Pass	_____	_____	N/A
Position 29	Pass	_____	_____	N/A
Position 30	Pass	_____	_____	N/A
Position 31	Pass	_____	_____	N/A
Position 32	Pass	_____	_____	N/A
Clock recovery frequency range	Pass	_____	_____	N/A

Signal Acquisition System Checks

These procedures check those characteristics that relate to the signal-acquisition system and are listed as checked under *Warranted Characteristics* in *Specifications*. Refer to Table 4-1 on page 4-18 for test equipment specifications.

Check DC Voltage Measurement Accuracy

Equipment required	Two dual-banana connectors (Item 5) One BNC T connector (Item 6) One DC calibration generator (Item 9) One SMA male-to-female BNC adapter (Item 19) Two precision 50 Ω coaxial cables (Item 4)
Prerequisites	The oscilloscope must meet the prerequisites listed on page 4-17



WARNING. *The generator is capable of outputting dangerous voltages. Be sure to set the DC calibration generator to off or 0 volts before connecting, disconnecting, and/or moving the test hookup during the performance of this procedure. Also, check that the calibrator does not have shorting straps installed between the DC and sense outputs or grounds.*

1. *Install the test hookup and preset the instrument controls:*
 - a. *Hook up the test-signal source:*
 - Set the output of a DC calibration generator to off or 0 volts.
 - Connect the output of a DC calibration generator through a dual-banana connector followed by a 50 Ω precision coaxial cable to one side of a BNC T connector. See Figure 4-8.
 - Connect the Sense output of the generator through a second dual-banana connector followed by a 50 Ω precision coaxial cable to the other side of the BNC T connector. Now connect the BNC T connector to **CH 1** through an adapter. See Figure 4-8.

- c. *Set the vertical scale:* Set the vertical **SCALE** to one of the settings listed in Table 4-2 that is not yet checked. (Start with the first setting listed).

Table 4-2: DC Voltage measurement accuracy

Scale setting	Position setting (Divs)	Offset setting ¹	Generator setting	Accuracy limits
50 mV	-5	+0.5 V	+900 mV	+883.50 mV to +916.50 mV
	+5	-0.5 V	-900 mV	-916.50 mV to -883.50 mV
100 mV	-5	+5 V	+5.5 V	+5.45 V to 5.55 V
	+5	-5 V	-5.5 V	-5.55 V to -5.45 V
1 V	-5	+2.5 V	+4.5 V	+4.20 V to 4.80 V
	+5	-2.5 V	-4.5 V	-4.80 V to -4.20 V

¹ Set as precisely as the instrument's offset resolution permits.

- d. *Display the test signal:*
- From the tool bar touch **VERT** and touch **Position**.
 - Use the keypad to set vertical position to -5 divisions (press **CLR**, **5**, **-**, and then **ENTER**, on the keypad). The baseline level will move off screen.
 - Touch **Offset**.
 - Use the keypad to set vertical offset to the positive-polarity setting listed in the table for the current vertical scale setting. The baseline level will remain off screen.
 - Set the generator to the level and polarity indicated in the table for the vertical scale, position, and offset settings you have made. The DC test level should appear on screen. (If it doesn't return, the DC accuracy check has failed for the current vertical scale setting of the current channel).
- e. *Measure the test signal:* Press **Close**. Read the measurement results at the **Mean** measurement readout. See Figure 4-9.

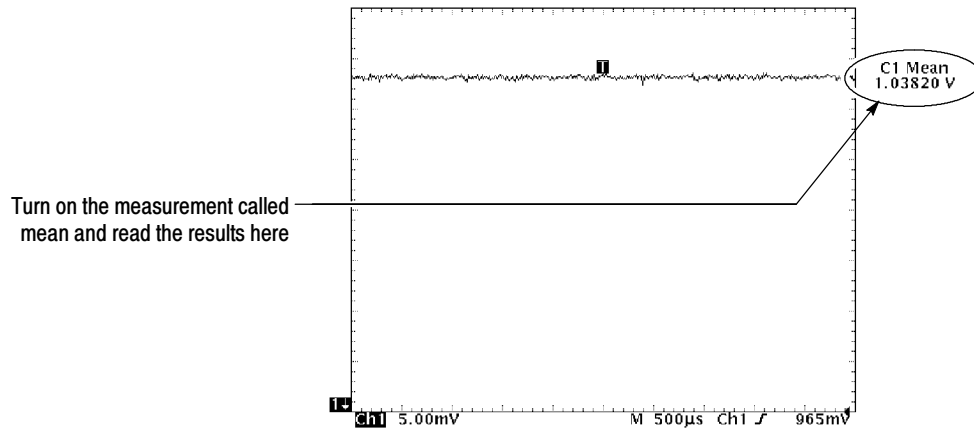

Figure 4-9: Measurement of DC accuracy at maximum offset and position

f. *Check against limits:*

- CHECK that the readout for the measurement **Mean** readout on screen is within the limits listed for the current vertical scale and position/offset/generator settings. Enter value on test record.
- Repeat substep d, reversing the polarity of the position, offset, and generator settings as is listed in the table.
- CHECK that the **Mean** measurement readout on screen is within the limits listed for the current vertical scale setting and position/offset/generator settings. Enter value on test record.
- Repeat substeps c through f until all vertical scale settings, listed in Table 4-2, are checked for the channel under test.

g. *Test all channels:* Repeat substeps a through f for all four channels.

3. *Disconnect the hookup:*

- a.** *Set the generator output to 0 V.*
- b.** Disconnect the cable and adapter from the generator output and the input connector of the channel last tested.

Check Offset Accuracy

Equipment required	Two dual-banana connectors (Item 5) One BNC T connector (Item 6) One DC calibration generator (Item 9) One SMA male-to-female BNC adapter (Item 19) Two precision 50 Ω coaxial cables (Item 4)
Prerequisites	The oscilloscope must meet the prerequisites listed on page 4-17



WARNING. *The generator is capable of outputting dangerous voltages. Be sure to set the DC calibration generator to off or 0 volts before connecting, disconnecting, and/or moving the test hookup during the performance of this procedure. Also, check that the calibrator does not have shorting straps installed between the DC and sense outputs or grounds.*

1. *Install the test hookup and preset the instrument controls:*
 - a. *Hook up the test-signal source:*
 - Set the output of a DC calibration generator to off or 0 volts.
 - Connect the output of a DC calibration generator through a dual-banana connector followed by a 50 Ω precision coaxial cable to one side of a BNC T connector. See Figure 4-10.
 - Connect the Sense output of the generator through a second dual-banana connector followed by a 50 Ω precision coaxial cable to the other side of the BNC T connector. Now connect the BNC T connector to **CH 1** through an adapter. See Figure 4-10.

- c. *Set the vertical scale:* Set the vertical **SCALE** to one of the settings listed in Table 4-3 that is not yet checked. (Start with the first setting listed).

Table 4-3: Offset accuracy

Scale setting	Position setting (Divs)	Offset setting ¹	Generator setting	Accuracy limits
50 mV	0	+0.5 V	+500 mV	+491.75 mV to +508.25 mV
		0 V	0.0 mV	-6.5 mV to +6.5 mV
		-0.5 V	-500 mV	-508.25 mV to -491.75 mV
100 mV	0	+5 V	+5.0 V	+4.9575 V to +5.0425 V
		0 V	0.0 V	-25 mV to +25 mV
		-5 V	-5.0 V	-5.0425 V to -4.9575 V
500 mV	0	+5 V	+5.0 V	+4.9175 V to +5.0825 V
		0 V	0.0 V	-65 mV to +65 mV
		-5 V	-5.0 V	-5.0825 V to -4.9175 V
1 V	0	+2.5 V	+2.5 V	+2.37625 V to +2.62375 V
		0 V	0.0 V	-115 mV to +115 mV
		-2.5 V	-2.5 V	-2.62375 V to -2.37625 V

¹ Set as precisely as the instrument's offset resolution permits.

- d. *Display the test signal:*
- From the tool bar touch **VERT** and then touch **Position**.
 - Use the keypad to set vertical position to 0.0 divisions (press **CLR** and then **ENTER**, on the keypad).
 - Touch **Offset**.
 - Use the keypad to set vertical offset to the positive-polarity setting listed in the table for the current vertical scale setting. The baseline level may move off screen.
 - Set the generator to the level and polarity indicated in the table for the vertical scale, position, and offset settings you have made. The DC test level should appear on screen. (If it doesn't return, the offset accuracy check has failed for the current vertical scale setting of the current channel).
- e. *Measure the test signal:* Press **Close**. Read the measurement results at the **Mean** measurement readout. See Figure 4-11.

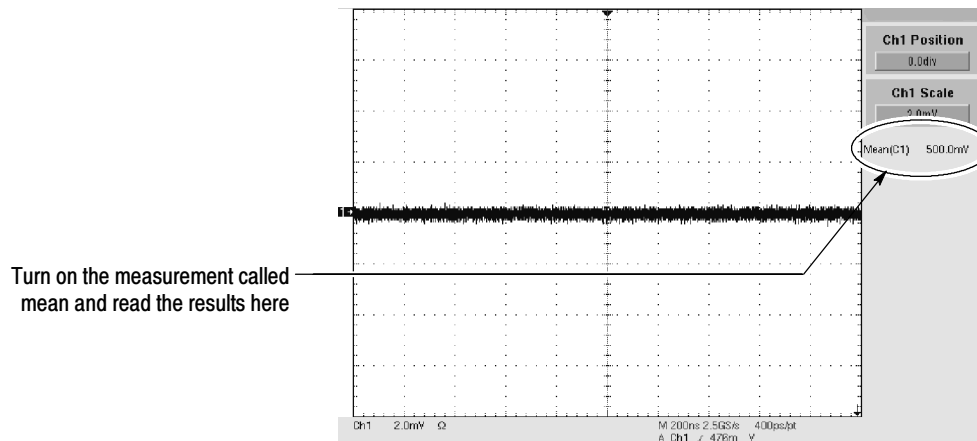

Figure 4- 11: Measurement of offset accuracy

f. Check against limits:

- CHECK that the readout for the measurement **Mean** readout on screen is within the limits listed for the current vertical scale and position/offset/generator settings. Enter value on test record.
- Repeat substep d, using the zero offset and generator settings as is listed in the table.
- CHECK that the **Mean** measurement readout on screen is within the limits listed for the current vertical scale setting and position/offset/generator settings. Enter value on test record.
- Repeat substep d, using the negative-polarity offset and generator settings as is listed in the table.
- CHECK that the **Mean** measurement readout on screen is within the limits listed for the current vertical scale setting and position/offset/generator settings. Enter value on test record.
- Repeat substeps c through f until all vertical scale settings, listed in Table 4-3, are checked for the channel under test.

g. Test all channels: Repeat substeps a through f for all four channels.

3. Disconnect the hookup:

- a. Set the generator output to 0 V.**
- b. Disconnect the cable and adapter from the generator output and the input connector of the channel last tested.**

Check Maximum Input Voltage

Equipment required	Two dual-banana connectors (Item 5) One BNC T connector (Item 6) One 10X attenuator (Item 1) One DC calibration generator (Item 9) One SMA male-to-female BNC adapter (Item 19) Two precision 50 Ω coaxial cables (Item 4)
Prerequisites	The oscilloscope must meet the prerequisites listed on page 4-17



WARNING. *The generator is capable of outputting dangerous voltages. Be sure to set the DC calibration generator to off or 0 volts before connecting, disconnecting, and/or moving the test hookup during the performance of this procedure. Also, check that the calibrator does not have shorting straps installed between the DC and sense outputs or grounds.*

1. *Install the test hookup and preset the instrument controls:*
 - a. *Hook up the test-signal source:*
 - Set the output of a DC calibration generator to off or 0 volts.
 - Connect the output of a DC calibration generator through a dual-banana connector followed by a 50 Ω precision coaxial cable to one side of a BNC T connector. See Figure 4-12.
 - Connect the Sense output of the generator through a second dual-banana connector followed by a 50 Ω precision coaxial cable to the other side of the BNC T connector. Now connect the BNC T connector to **CH 1** through a 10X attenuator and an adapter. See Figure 4-12.

- Press **Close**.
- c. *Set the vertical scale:*
- Set the vertical **SCALE** to one of the settings listed in Table 4-4 that is not yet checked. (Start with the first setting listed).
 - From the tool bar touch **VERT** and touch **Position**.
 - Use the keypad to set vertical position to -3 divisions (press **CLR**, **3**, **-**, and then **ENTER**, on the keypad).
 - Set the Coupling to **DC**.
 - Touch **Offset**.
 - Use the keypad to set vertical offset to 0 V.
 - Press **Close**.

Table 4-4: Maximum input voltage limit

Scale setting	Position setting (Divs)	Offset setting	Generator setting	Readout with 10X attenuator	Limits (without 10X attenuator)
50 mV	-3	0 V	+1 V	+100 mV	Coupling in CH readout stays Ω
			+3 V	+300 mV	Coupling changes to ground
1 V	-3	0 V	+5 V	+500 mV	Coupling in CH readout stays Ω
			+10 V	+1.0 V	Coupling changes to ground

- d. *Display the test signal:* Set the generator to the level and polarity indicated in the table for the vertical scale, position, and offset settings you have made, or set the generator for the readout indicated in the table for the vertical scale, position, and offset settings you have made. See Figure 4-13.

NOTE. When setting the Wavetek to output 10 V, use the following procedure:

Press the **Aux** button

Press the fourth soft key down (Selects the pulse with an exclamation point)

Set the amplitude to 10 V

Press the **->|** key to select the pulse energy

Set the energy to 50J

Press the **Output On** key

Press the **Trig Pulse** soft key to trigger the pulse (this will generate a 10 V pulse with 25 seconds duration).

Use the normal DC output for the 1 V, 3 V, and 5 V generator settings.

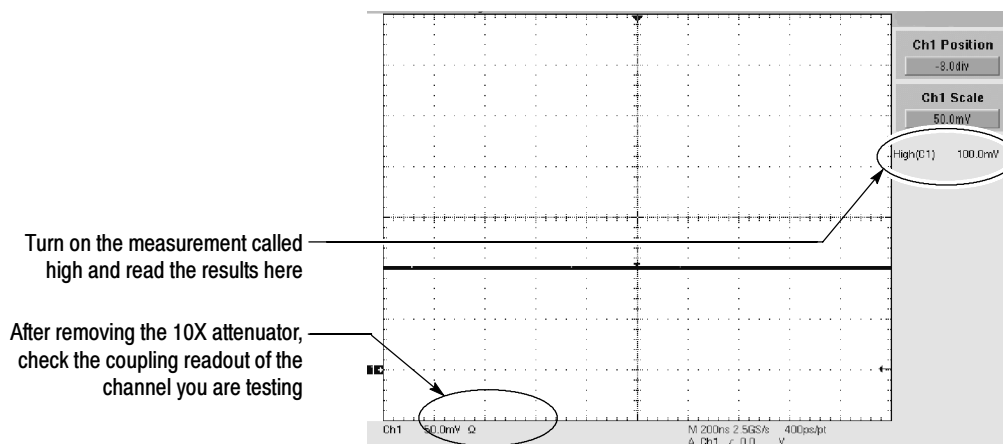

Figure 4-13: Check of maximum input voltage

- e. *Check an unchecked generator setting against limits:*
 - Remove the 10X attenuator.
 - Connect the generator signal directly to the oscilloscope.
 - CHECK that the coupling readout on screen for the selected channel is as listed for the current vertical scale and position/offset/generator settings.
 - Reinstall the 10X attenuator.
- f. *Check the next generator setting:* Repeat substeps d and e, using the new generator setting as is listed in the table.
- g. *Check the remaining vertical scale settings:* Repeat substeps c through f until all vertical scale settings, listed in Table 4-4, are checked for the channel under test.

- h. *Test all channels:* Repeat substeps a through g for all vertical channels.
3. *Disconnect the hookup:*
- a. *Set the generator output to 0 V.*
 - b. Disconnect the cable, attenuator, and adapter from the generator output and the input connector of the channel last tested.

Check Analog Bandwidth

Equipment required	One sine wave generator (Item 12) One level meter and power sensor (Item 13) One power divider (Item 14) One female N to male BNC adapter (Item 16) Four male N to female BNC adapters (Item 15) Two 50 Ω precision cables (Item 4) Attenuators (Items 1 and 2) One SMA male-to-female BNC adapter (Item 19)
Prerequisites	See page 4-17

1. *Install the test hookup and preset the instrument controls:*
- a. *Initialize the oscilloscope:*
 - Press **DEFAULT SETUP**.
 - b. *Modify the default settings:*
 - Turn the horizontal **SCALE** knob to 200 ns.
 - From the tool bar, touch **Horiz** and select the **Acquisition** tab. Set the acquisition mode as follows:
 - TDS6604: Touch **Sample**.
 - TDS6404: Touch **Average** and set the number of averages to **16**.
 - Set the sampling mode as follows:
 - TDS6604: Touch the **Interpolated Real Time IT** button.
 - TDS6404: Touch the **Equivalent Time ET** button.
 - From the tool bar, touch **MEAS**. Touch Setup **Ref Levs**; then touch the Determine Base, Top Form **Min-Max** button.

NOTE. The sine wave generator output amplitude must be leveled to within 0.35 db of the reference frequency (10 MHz) through the bandwidth frequency listed in Table 4-5 on page 4-43. The 0.35 db requirement is necessary to ensure a bandwidth that meets Tektronix specifications.

You can perform bandwidth PV using an unlevelled sine wave generator (with amplitude error > 0.35 db). Under these conditions, the bandwidth PV is subject to the flatness errors associated with the generator used.

Refer to the Sine Wave Generator Leveling Procedure on page 4-90 if your sine wave generator does not have automatic output amplitude leveling.

- c. *Hook up the test-signal source:* Connect the sine wave output of a leveled sine wave generator to **CH 1**. Set the output of the generator to a reference frequency of 50 MHz or less. See Figure 4-14.

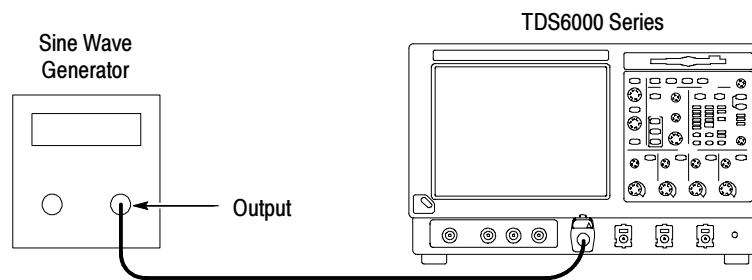

Figure 4-14: Initial test hookup

2. *Confirm the input channels are within limits for analog bandwidth:* Do the following substeps — test CH 1 first, *skipping substeps a and b since CH 1 is already set up for testing from step 1.*
 - a. *Select an unchecked channel:*
 - From the tool bar, touch **MEAS** and then **Clear** to remove all previous measurements.
 - Press the Vertical button of the channel just confirmed to remove the channel from the display.
 - Press the front-panel Vertical button that corresponds to the channel you are to confirm.
 - Move the leveled output of the sine wave generator to the channel you selected.

- b. *Match the trigger source to the channel selected:* Press the Trigger **SOURCE** button until the source that corresponds to the channel you are to confirm is on.
- c. *Set the vertical scale:* Set the vertical **SCALE** that corresponds to the channel you are to confirm to one of the settings listed in Table 4-5 not yet checked. (Start with the 100 mV setting).
- d. *Set the triggering coupling:* Touch the Coupling **DC** button.

Table 4-5: Analog bandwidth

Vertical scale	Reference amplitude (6 divisions)	Horizontal scale	Test frequency		Limits
			TDS6404	TDS6604	-3 dB Limits
10 mV	60 mV	1 ns	4 GHz	6 GHz	≥42.4 mV
20 mV	120 mV	1 ns	4 GHz	6 GHz	≥84.8 mV
50 mV	300 mV	1 ns	4 GHz	6 GHz	≥212 mV
100 mV	600 mV	1 ns	4 GHz	6 GHz	≥424 mV
200 mV	1.2 V	1 ns	4 GHz	6 GHz	≥848 mV
500 mV	3 V ¹	1 ns	4 GHz	6 GHz	≥2.12 V ¹
1 V	5 V ¹	1 ns	4 GHz	6 GHz	≥3.535 V ¹

¹ If your generator cannot output the required amplitude, determine its maximum output at the Test frequency, and use this for the reference amplitude. The -3 db limit can be calculated as: $0.707 \times$ reference amplitude.

- e. *Display the test signal:* Do the following subparts to first display the reference signal and then the test signal.
 - From the button bar touch **MEAS**; then select the **Time** tab.
 - Touch the **Freq** button to measure the frequency of the current channel.
 - Select the **Ampl** tab. Touch the **Pk-Pk** button.
 - Touch **Close** button.
 - Set the generator output so the CHx Pk-Pk readout equals the reference amplitude in Table 4-5 that corresponds to the vertical scale set in substep c.

- Set the trigger as follows:

TDS6604: Touch the Source **Line** button.

TDS6404: Press the front-panel **PUSH TO SET 50%** as necessary to trigger a stable display. At full bandwidth, you may also want to make small, manual adjustments to the trigger level. You can use the **Trigger LEVEL** knob to do this.

f. Measure the test signal:

- Set the frequency of the generator, as shown on screen, to the test frequency in Table 4-5 that corresponds to the vertical scale set in substep c. See Figure 4-15.
- Set the horizontal **SCALE** to the horizontal scale setting in Table 4-5 that corresponds to the vertical scale set in substep c. Press **PUSH TO SET 50%** as necessary to trigger the signal.
- Read the results at the CHx Pk-Pk readout, which will automatically measure the amplitude of the test signal. See Figure 4-15.

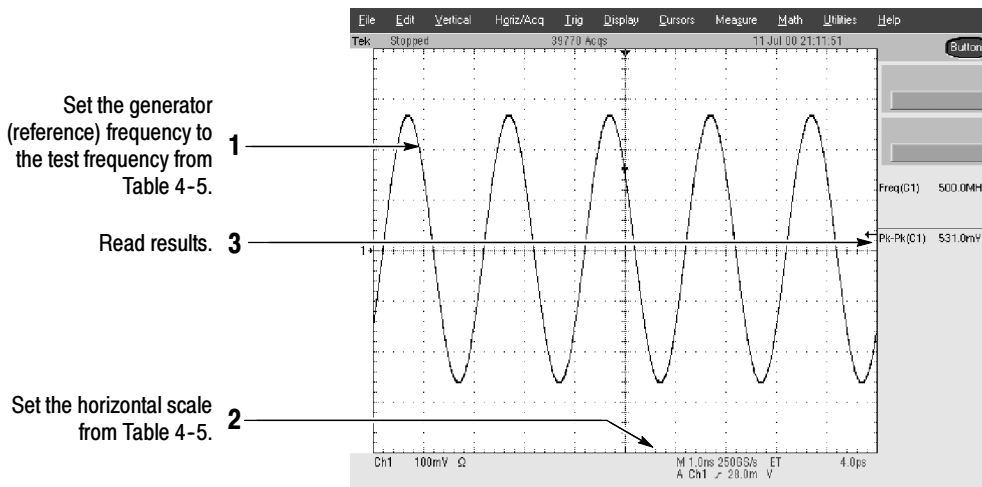

Figure 4-15: Measurement of analog bandwidth

g. Check against limits:

- CHECK that the **Pk-Pk** readout on screen is within the limits listed in Table 4-5 for the current vertical scale setting.
- Enter voltage on the test record.
- When finished checking, set the horizontal **SCALE** back to the 40 ns setting.

STOP. *Checking each channel's bandwidth at all vertical scale settings is time consuming and unnecessary. You may skip checking the remaining vertical scale settings in Table 4-5 (that is, skip the following substep, h) if this oscilloscope has performed as follows:*

- Passed the 100 mV vertical scale setting just checked in this procedure.
- Passed the *Verify Internal Adjustment, Self Compensation, and Diagnostics* procedure found under *Self Tests*, on page 4-5.

NOTE. *Passing the signal path compensation confirms the signal path for all vertical scale settings for all channels. Passing the internal diagnostics ensures that the factory-set adjustment constants that control the bandwidth for each vertical scale setting have not changed.*

h. *Check remaining vertical scale settings against limits (optional):*

- If desired, finish checking the remaining vertical scale settings for the channel under test by repeating substeps c through g for each of the remaining scale settings listed in Table 4-5 for the channel under test.
- When doing substep e, skip the subparts that turn on the CHx Pk-Pk measurement until you check a new channel.
- Before doing substep f, touch the **Clear** button to remove the previous channel measurements.
- Install/remove attenuators between the generator leveled output and the channel input as needed to obtain the six division reference signals listed in the table.
- When finished bandwidth checks for a particular channel, clear all measurements for that channel.

i. *Test all channels:* Repeat substeps a through g for all four channels.

3. *Disconnect the hookup:* Disconnect the test hook up from the input connector of the channel last tested.

Check Delay Between Channels

Equipment required	One sine wave generator (Item 12) Three precision 50 Ω coaxial cables (Item 4) One power divider (Item 14) 3 SMA female to female adapter connector (Item 17) 3 SMA male-to-female BNC adapter connector (Item 18) Two SMA male-to-female BNC adapter (Item 19)
Prerequisites	See page 4-17

STOP. *DO NOT use the vertical position knob to reposition any channel while doing this check. To do so invalidates the test.*

1. *Install the test hookup and preset the instrument controls:*
 - a. *Initialize the front panel:* Press the **DEFAULT SETUP** button.
 - b. *Modify the initialized front-panel control settings:*
 - Do *not* adjust the vertical position of any channel during this procedure.
 - Set the horizontal **SCALE** to 500 ps.
 - From the tool bar, touch **Horiz** and select the **Acquisition** tab.
 - Touch **Average** and set the number of averages to **16**.
 - c. *Hook up the test-signal source:*
 - Connect the sine wave output of a sine wave generator to a 50 Ω precision coaxial cable followed by a power divider.
 - Connect the power divider to both **CH 1** and **CH 2**. See Figure 4-16.

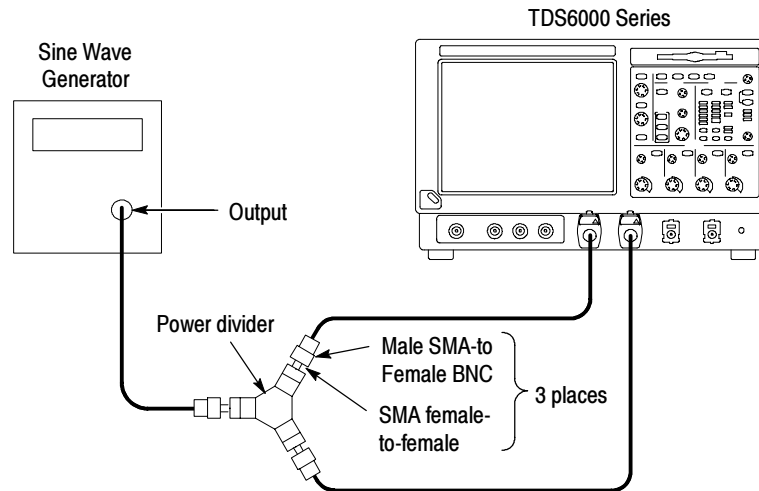

Figure 4-16: Initial test hookup

2. Confirm all four channels are within limits for channel delay:

- a. Set up the generator:** Set the generator frequency to 500 MHz and the amplitude for six to eight divisions in CH 1.

Hint: As you are adjusting the generator amplitude, push **PUSH TO SET 50%** frequently to speed up the updating of the waveform amplitude on screen.

- b.** The horizontal **SCALE** should already be set to 500 ps. Now set it to 125 ps.
- c. Save a CH 2 waveform:** Press the **CH 2 Vertical** button. From the button bar, touch the **Refs** button and select the **Ref 2** tab. Touch the Save Wfm to Ref2 **Save** button.
- d. Save CH 3 waveform:**
- Move the power divider from **CH 2** to **CH 3**, so that **CH 1** and **CH 3** are driven. Press the Vertical **CH 2** and **CH 3** buttons. Select the **Ref 3** tab and touch the Ch Channel 3 button. Touch the Save Wfm to Ref3 **Save** button.
- e. Display all test signals:**
- Press the **CH 3 Vertical** button to remove CH 3 from the display.
 - Display the live waveform. Move the power divider from **CH 3** to **CH 4**, so that CH 1 and CH 4 are driven. Press the Vertical **CH 4** button to display. See Figure 4-17 on page 4-48.

- Display the reference waveforms. To do this, touch the Ref 3 Display **Off** button to toggle it to On and display the reference. Select the **Ref 2** tab and touch the Display **Off** button to toggle it to On. You may notice their overlapping waveform handle icons. See Figure 4-17 on page 4-48.

f. *Measure the test signal:*

- Locate the time reference points for these waveforms. Do this by first identifying the point where the rising edge of the left-most waveform crosses the center horizontal graticule line. Next, note the corresponding *time reference point* for the right-most waveform. See Figure 4-17 on page 4-48.
- Press **CURSORS** and select the **V Bars** Cursors Type.
- Touch the **Close** button.

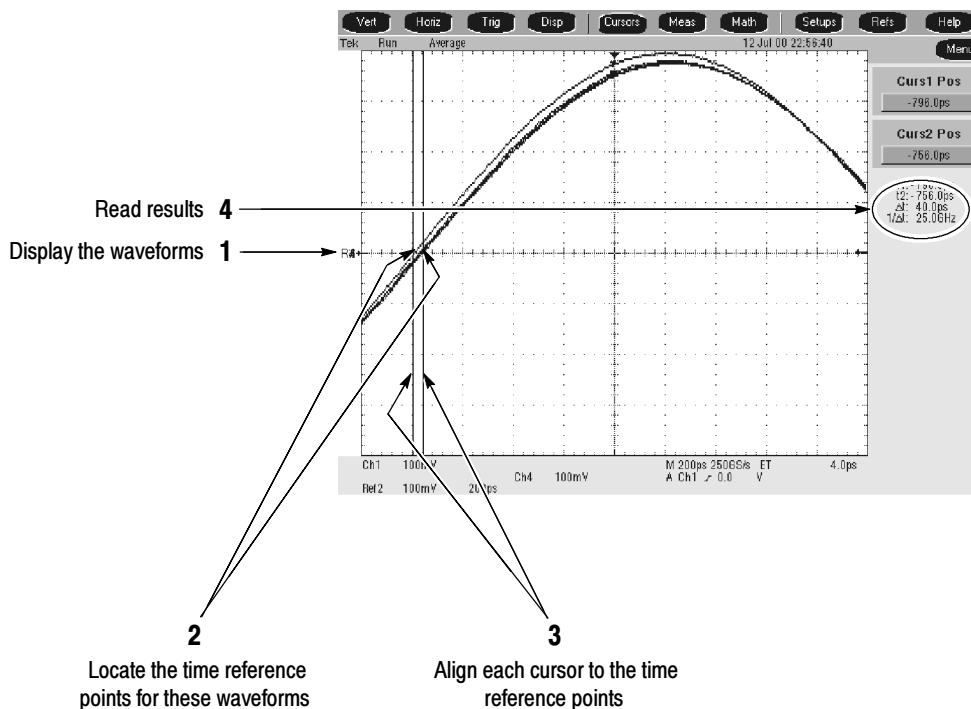

Figure 4-17: Measurement of channel delay

- g.** *Check against limits:* Use the cursors to measure the skew from CH 1 to CH 2, CH 1 to CH 3, and CH 1 to CH 4. Write down these three numbers in the first measurement column of Table 4-6. Note that these numbers may be either positive or negative.

- h. Move the power divider on CH 1 to CH 2. Move the power divider on CH 4 to CH 1.

NOTE. To eliminate errors caused by cables and adapters, the measurements are repeated and averaged after swapping channel position of cables.

- i. Repeat the procedure from step 2.c through 2.e.
- j. Again use the cursors to measure the skew from CH 1 to CH 2, CH 1 to CH 3, and CH 1 to CH 4. Write down these numbers in the second measurement column of Table 4-6. Note that these numbers may be either positive or negative.
- k. Add the first CH 1 to CH 2 skew measurement to the second CH 1 to CH 2 skew measurement and divide the result by 2. Use Table 4-6.
- l. Add the first CH 1 to CH 3 skew measurement to the second CH 1 to CH 3 skew measurement and divide the result by 2. Use Table 4-6.
- m. Add the first CH 1 to CH 4 skew measurement to the second CH 1 to CH 4 skew measurement and divide the result by 2. Use Table 4-6.
- n. Check against limits: CHECK that the largest of the three results from steps k, l, and m is between -30 ps and + 30 ps.
- o. Enter the time on the test record.

Table 4-6: Delay between channels worksheet

Coupling	First measurement	Second measurement	Add first and second measurements	Divide sum by 2
CH 1 to CH 2 skew				
CH 1 to CH 3 skew				
CH 1 to CH 4 skew				

3. *Disconnect the hookup:* Disconnect the cable from the generator output at the input connectors of the channels.

**Check Channel Isolation
(Crosstalk)**

Equipment required	One leveled sine-wave generator (Item 12) One 2X attenuator (Item 26) Four TCA-BNC adapters (Item 19) Three 50 Ω terminators (Item 3) One 50 Ω , precision coaxial cable (Item 4)
Prerequisites	See page 4-17

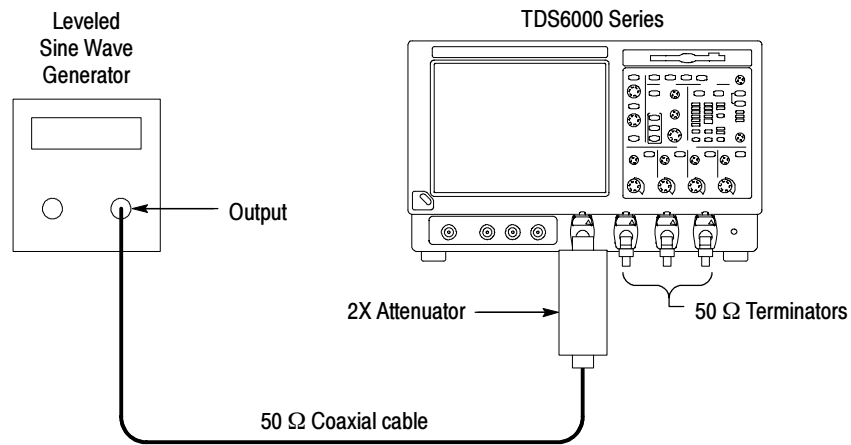
**Figure 4- 18: Initial test hookup**

1. *Install the test hookup and preset the instrument controls:*
 - a. *Initialize the oscilloscope:* Press the **DEFAULT SETUP** button.
 - b. *Modify the initialized control settings:*
 - Turn on all vertical channels (press the Vertical button of any off channels: CH 1, CH 2, CH 3, and CH 4).
 - Set the Horizontal SCALE to **1.25 ns**.
 - Set the Vertical SCALE of CH 1, CH 2, CH 3, and CH 4 to **100 mV**.
 - From the tool bar, touch **Horiz** and select the **Acquisition** tab.
 - Touch **Average** and set the number of averages to **16**.
 - Touch the **Equivalent Time ET** button.
 - From the button bar, touch **MEAS**.
 - Touch the Source Channel **1** button.

- Select the **Ampl** tab; then touch the **Amplitude** button.
 - Touch **Close**.
 - Set the Trigger SOURCE to **CH 1**.
 - Press **PUSH TO SET 50%**.
- c. *Hook up the test-signal source:*
- Connect, through a 50 Ω precision coaxial cable, a 2X attenuator, and a TCA-BNC adapter, the output of the generator to **CH 1** (see Figure 4-18).
 - Connect TCA-BNC adapters to the CH 2, CH 3, and CH 4 inputs.
 - Connect 50 Ω terminators to the adapters on the CH 2, CH 3, and CH 4 inputs.

2. *Display the test signal:*

- Set the generator to output a 1.5 GHz sine wave. Set the test signal amplitude for about five divisions on screen. Now fine adjust the generator output until the **CH 1 Amplitude** readout indicates the amplitude is 500 mV. Readout may fluctuate around 500 mV.
- Remove the 2X attenuator.

3. Confirm the input channels are within limits for channel isolation:

- a. Check — Amplitude of each trace other than CH 1 is 0.125 division or less (discount trace width). Enter the largest amplitude on the test record.
- b. Move the signal to the **CH 2** input connector, change the Trigger SOURCE to **CH 2**, and move the 50 Ω terminator to the CH 1 input.
- c. Check — Amplitude of each trace other than CH 2 is 0.125 division or less (discount trace width). Enter the largest amplitude on the test record.
- d. Move the signal to the **CH 3** input connector, change the Trigger SOURCE to **CH 3**, and move the 50 Ω terminator to the CH 2 input.
- e. Check — Amplitude of each trace other than CH 3 is 0.125 division or less (discount trace width). Enter the largest amplitude on the test record.
- f. Move the signal to the **CH 4** input connector, change the Trigger SOURCE to **CH 4**, and move the 50 Ω terminator to the CH 3 input.
- g. Check — Amplitude of each trace other than CH 4 is 0.125 division or less (discount trace width). Enter the largest amplitude on the test record.

h. Select an unchecked vertical SCALE:

- Connect the 2X attenuator to the CH 1 input.
- Move the signal to the CH1 input, change the Trigger Source to **CH 1**, and move the 50 Ω terminator to the CH 4 input.
- Press **PUSH TO SET 50%**.
- Set the Vertical SCALE of CH 1, CH 2, CH 3, and CH 4 to **50 mV**
- Set the test signal amplitude for about five divisions on screen. Now fine adjust the generator output until the **CH 1 Amplitude** readout indicates the amplitude is 250 mV. Readout may fluctuate around 250 mV.
- Remove the 2X attenuator.
- Repeat steps a through g.
- Connect the 2X attenuator to CH 1.
- Move the signal to the CH 1 input, change the Trigger Source to **CH 1**, and move the 50 Ω terminator to the CH 4 input.
- Press **PUSH TO SET 50%**.
- Set the Vertical SCALE of CH 1, CH 2, CH 3, and CH 4 to **10 mV**
- Set the test signal amplitude for about five divisions on screen. Now fine adjust the generator output until the **CH 1 Amplitude** readout indicates the amplitude is 50 mV. Readout may fluctuate around 50 mV.
- Remove the 2X attenuator.
- Repeat steps a through g.

4. *Display the test signal:*

- Connect the 2X attenuator to CH 1.
- Move the signal to the CH 1 input, change the Trigger Source to **CH 1**, and move the 50 Ω terminator to the CH 4 input.
- Press **PUSH TO SET 50%**.
- Set the Vertical SCALE of CH 1, CH 2, CH 3, and CH 4 to **100 mV**.

- Set the Horizontal SCALE to 2 to 5 cycles of the signal.
 - Set the generator output at a sine wave of **4 GHz** bandwidth to check your oscilloscope. Set the test signal amplitude for about five divisions on screen. Now fine adjust the generator output until the **CH 1 Amplitude** readout indicates the amplitude is 500 mV. Readout may fluctuate around 500 mV.
 - Remove the 2X attenuator.
5. Confirm the input channels are within limits for channel isolation:
- a. Check — Amplitude of each trace other than CH 1 is 0.5 division or less (discount trace width). Enter the largest amplitude on the test record.
 - b. Move the signal to the CH 2 input connector, change the Trigger SOURCE to CH 2, and move the 50 Ω terminator to the CH 1 input.
 - c. Check — Amplitude of each trace other than CH 2 is 0.5 division or less (discount trace width). Enter the largest amplitude on the test record.
 - d. Move the signal to the CH 3 input connector, change the Trigger SOURCE to CH 3, and move the 50 Ω terminator to the CH 2 input.
 - e. Check — Amplitude of each trace other than CH 3 is 0.5 division or less (discount trace width). Enter the largest amplitude on the test record.
 - f. Move the signal to the CH 4 input connector, change the Trigger SOURCE to CH 4, and move the 50 Ω terminator to the CH 3 input.
 - g. Check — Amplitude of each trace other than CH 4 is 0.5 division or less (discount trace width). Enter the largest amplitude on the test record.
 - h. Select an unchecked Vertical SCALE:
 - Connect the 2X attenuator to CH 1.
 - Move the signal to CH 1, set the Trigger SOURCE to CH 1, and move the 50 Ω terminator to the CH 4 input.
 - Press **PUSH TO SET 50%**.
 - Set the Vertical SCALE of CH 1, CH 2, CH 3, and CH 4 to **50 mV**
 - Set the test signal amplitude for about five divisions on screen. Now fine adjust the generator output until the **CH 1 Amplitude** readout indicates the amplitude is 250 mV. Readout may fluctuate around 250 mV.
 - Remove the 2X attenuator.
 - Repeat steps a through g.

- Connect the 2X attenuator to CH 1.
 - Move the coaxial cable to CH 1, set the Trigger SOURCE to CH 1, and move the 50 Ω terminator to the CH 4 input.
 - Set the Vertical SCALE of CH 1, CH 2, CH 3, and CH 4 to **10 mV**
 - Set the test signal amplitude for about five divisions on screen. Now fine adjust the generator output until the **CH 1 Amplitude** readout indicates the amplitude is 50 mV. Readout may fluctuate around 50 mV.
 - Remove the 2X attenuator.
 - Repeat steps a through g.
6. *Disconnect the hookup:* Disconnect the cable, terminators, and adapters from the generator output and the input connector of the channel.

Check Input Impedance

Equipment required	One Digital Multimeter (Item 27) One Dual-Banana Connector, (Item 5) One precision 50 Ω coaxial cable (Item 4) One SMA male-to-female BNC adapter (Item 19)
Prerequisites	See page 4-17

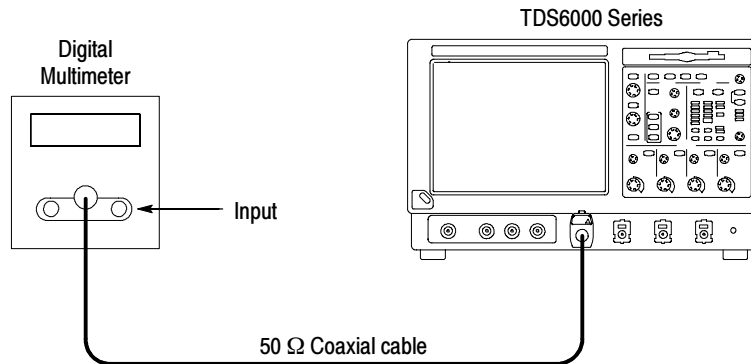

Figure 4- 19: Initial test hookup

1. *Install the test hookup and preset the instrument controls:*
 - a. *Hook up the test-signal source:* Connect, through a 50 Ω precision coaxial cable, the input of the multimeter to **CH 1** through adapters (see Figure 4-19).
 - b. Set the Vertical **SCALE** to **10 mV** per division
2. *Check input impedance against limits:*
 - a. *Measure the impedance:* Read and record the measured impedance.
 - b. Remove the dual banana connector from the digital multimeter (DMM), turn it 180 degrees and reinsert it in the DMM input.
 - c. *Measure the impedance:* Read and record the measured impedance.
 - d. Add the two measurements and divide the result by 2.
 - e. Check — Average of the two measurements is ≥ 48.75 Ohms and ≤ 51.25 Ohms. Enter average on the test record.
3. Set the Vertical **SCALE** to **100 mV** per division and repeat step 2.
4. *Repeat steps 2 through 3 for the remaining input channels:*
 - a. Move the test setup to an unchecked input channel.
 - b. Set the Vertical **SCALE** of the channel to **10 mV** per division.
 - c. Repeat steps 2 through 3.
5. *Disconnect the hookup:* Disconnect the equipment from the oscilloscope.

Time Base System Checks

These procedures check those characteristics that relate to the time base system and are listed as checked under *Warranted Characteristics* in *Specifications*.

Check Long-Term Sample Rate and Delay Time Accuracy and Reference

Equipment required	One timer-counter (Item 11) One 50 Ω , precision coaxial cable (Item 4) One SMA male-to-female BNC adapter (Item 19) One sine wave generator (Item 12)
Prerequisites	See page 4-17

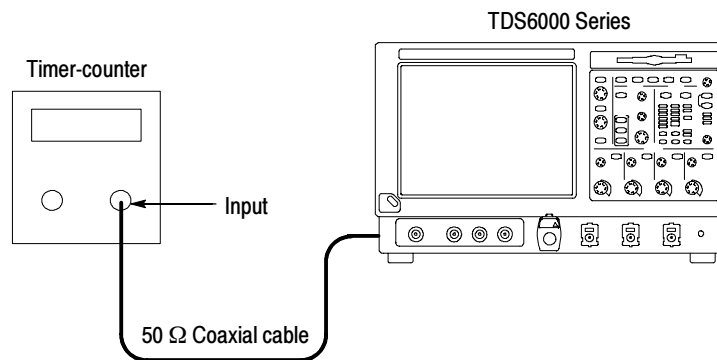

Figure 4-20: Initial test hookup

1. *Install the test hookup and preset the instrument controls:*
 - a. *Hook up the test-signal source:* Connect, through a 50 Ω precision coaxial cable, the input of the timer-counter to **REF OUT** (see Figure 4-20).
 - Set the timer-counter gate to 1 s.
 - Set the timer-counter to count the reference output.
 - b. *Initialize the oscilloscope:* Press the **DEFAULT SETUP** button.
2. *Confirm the time base is within limits for accuracies:*
 - a. *Check long-term sample rate and delay time accuracies against limits:*
 - CHECK that the count on the timer-counter is within limits.
 - Enter the count on the test record.

3. *Confirm reference is within limits for logic levels:*
 - a. *Display the test signal:*
 - Move the cable from the timer-counter to the CH 1 input through an adapter.
 - Set the Vertical **SCALE** to 1 V.
 - Use the Vertical **POSITION** knob to center the display on screen.
 - b. *Measure logic levels:*
 - From the button bar, touch **MEAS** and select the **Ampl** tab.
 - Touch the **High** and **Low** buttons.
 - Touch the **Close** button.
 - c. *Check REF OUT output against limits:* CHECK that the **CH 1 High** readout is ≥ 1.0 volt and that the **CH 1 Low** readout ≤ 0.25 volts.
4. *Disconnect the hookup:* Disconnect the cable and adapter from the oscilloscope.

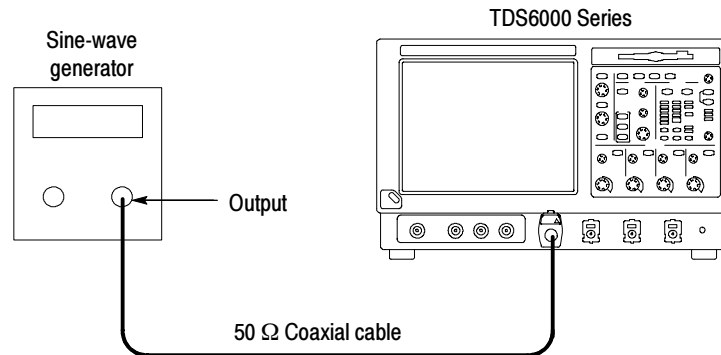

Figure 4-21: Initial test hookup

5. *Install the test hookup and preset the instrument controls:*
 - a. *Initialize the oscilloscope:* Press the **DEFAULT SETUP** button.
 - b. *Hook up the test-signal source:* Connect, through a 50 Ω precision coaxial cable, the output of the sine wave generator to **CH 1** input through an adapter (see Figure 4-21).
 - From the button bar, touch **MEAS** and select the **Ampl** tab.
 - Touch the **Pk-Pk** button.

- Touch the **Close** button.
 - Set the Vertical **SCALE** to 50 mV.
 - Set the generator for a 10.0 MHz sine wave.
 - Set the generator to output a 4 division signal. Adjust the output until the Pk-Pk readout displays 200 mV.
- c. *Set the oscilloscope controls:*
- Move the cable from the **CH 1** input to the rear-panel **Ext Ref** input (see Figure 4-22).
 - Touch **Menu** to select menu mode.
 - Touch **Utilities** and select **External Signals**.
 - Touch the **Internal** button to select the external reference (the button name changes to External).

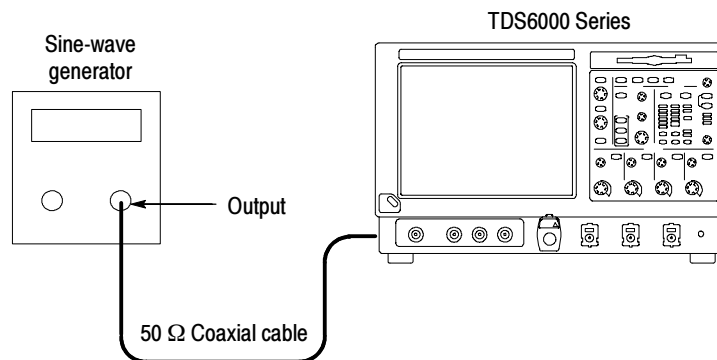

Figure 4-22: Final test hookup

6. *Confirm external reference:*
- a. *Perform a signal path compensation:*
 - Touch **Utilities** and select **Instrument Calibration**.
 - Touch **Calibrate** and wait for the signal path compensation to finish.
 - b. *Check the completion status:* If the Status is Fail, refer the instrument to qualified service personnel.
7. *Disconnect the hookup:*
- a. Disconnect all test equipment from the oscilloscope.

- b. *Set the instrument controls:*
 - From menu mode, touch **Utilities** and select **External Signals**.
 - Touch the **External** button to select the internal reference (the button name changes to Internal).
- c. *Perform a signal path compensation:*
 - Touch **Utilities** and select **Instrument Calibration**.
 - Touch **Calibrate** and wait for the signal path compensation to finish.

Check Delta Time Measurement Accuracy

Equipment required	One 50 Ω , precision coaxial cable (Item 4) One Connector, BNC "T", male BNC-to-dual female BNC (Item 6) One Pulse Generator, Wavetek 9500 or equivalent (Item 20) Two 50 Ω , coaxial cable, male-to-male SMA connectors (Item 21) One SMA female to BNC male connector (Item 23) One BNC elbow connector (Item 24) One SMA "T", male to two SMA female connectors (Item 22) Two SMA terminator connectors, short circuit, (Item 25) One SMA male-to-female BNC adapter (Item 19) One 2X attenuator, 50 Ω , female BNC-to-male BNC (Item 26)
Prerequisites	See page 4-17

This procedure checks the "sample rate" portion of the Delta Time Measurement Accuracy as listed in *Specifications*. The previous procedure, *Check Accuracy for Long-Term Sample Rate and Delay Time Accuracy and Reference*, see page 4-56, verified the "PPM" portion of the delta time specification.

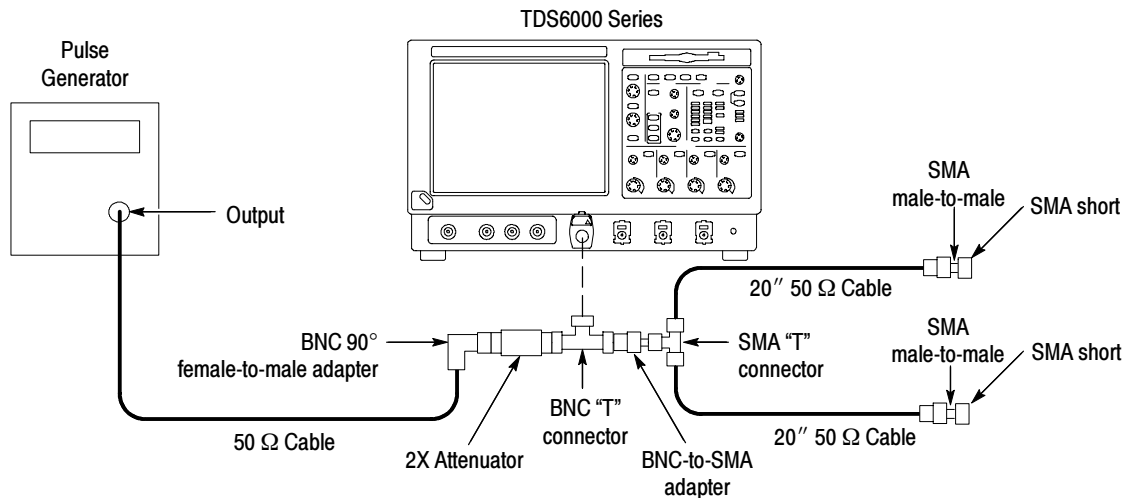

Figure 4-23: Delta time accuracy test hookup

1. *Install the test hookup and preset the instrument controls:*
 - a. *Initialize the oscilloscope:* Press the **DEFAULT SETUP** button.

- b. *Hook up the pulse generator (see Figure 4-23 on page 4-60):*
- Connect the pulse generator output to a **50 Ω** precision coaxial cable followed by a 90° right-angle female to male BNC adapter, then a **50 Ω** 2X attenuator. The attenuator is connected to one side of the female BNC T connector. The other side of the BNC T is connected to BNC male to SMA adapter. The SMA side is connected to the male side of the SMA T connector. (Keep the distance between the BNC T and SMA T as short as possible). Connect 20 inch **50 Ω** coaxial cables to each female side of the SMA T connector. Connect a female to female SMA adapter to both male coaxial connectors. Connect the SMA short, to the remaining female SMA adapter. Now connect the male BNC T connector to **CH 1**.
 - Set the pulse generator output for a positive-going pulse with a rise-time as shown in Table 4-7 on page 4-62 for your oscilloscope, and for the fastest possible rep rate (at least 1 kHz).
 - Set the pulse generator output for about 500 mV. (This amplitude can be adjusted later to get a 5-division pulse on screen.)
- c. *Modify the initialized front-panel control settings:*
- Press **AUTOSET**. You may see both positive and negative pulses. Adjust the Trigger **LEVEL** knob so the trigger level is about 50% of the rising edge of the positive pulse.
 - From the button bar, touch the **Horiz** button and select the **Acquisition** tab. Touch the **Real Time Only RT** button.
 - Set the horizontal **SCALE** to 5 ns/division. The pulse width should be about **6 ns**. The indicated sample rate should be 20 GS/s.
 - Adjust pulse amplitude and oscilloscope vertical scale and position as necessary to obtain about **5 divisions** of the **positive** pulse.

NOTE. *If you have followed the procedure, you should have a 250 mV pulse displayed on screen. Later in this procedure you will set the instrument to measure the pulse width at the 150 mV level.*

If the pulse you supply to the instrument is not a 250 mV pulse, you may need to set the reference level (MidRef) to something other than 150 mV. Set the reference level near the center of the pulse, above any noise, and below any overshoot or ringing on the pulse.

- d. *Set up for statistics measurements:*
- Re-adjust the Trigger **LEVEL** knob so the trigger level is about 50% of the rising edge of the positive pulse.

- Press **RUN/STOP** button to freeze the display.
- Touch **MEAS** and select the **Time** tab to bring up the Time Measurements menu.
- Touch the **Positive Width** button.
- Touch Setup **Statistics**. Touch the Measurement Statistics **All** button and then touch **Reset** to reset the statistics.
- Touch **Weight n=**. On the keypad press **1000**, then **ENTER**. Touch **Setup**.
- Touch Setup **Ref Levs** and then touch **Absolute**.
- Touch **MidRef**. Using the keypad or multipurpose knobs, set the mid reference to **150 mV**. Touch **Close**.
- Press the **RUN/STOP** button to start the acquisitions.
- Wait about 30 seconds.
- Press **RUN/STOP** button to freeze the display.
- Record the all statistics values.
- Calculate the difference of the Maximum (M) minus the mean (μ) of the statistics values.
- Calculate the difference of the mean (μ) minus the Minimum (m) of the statistics values.
- Both differences must be less than or equal to the Delta-time accuracy limit shown in Table 4-7 for your oscilloscope.
- Enter the result for delta time on the test record.

Table 4-7: Delta time measurement

Oscilloscope type	Pulse generator rise time range	Delta time accuracy limit
TDS6404	140 ps - 400 ps	≤ 0.030 ns
TDS6604	≤ 150 ps	≤ 0.015 ns
TDS6404	≤ 150 ps	≤ 0.015 ns

e. *Repeat for all other channels:*

- Note the vertical scale setting of the channel just confirmed.

- Press the Vertical channel button for the channel just confirmed to remove the channel from display.
- Touch **MEAS** and the **Clear** to remove the measurement.
- Press the front-panel button that corresponds to the channel you are to confirm.
- Set vertical **SCALE** to the setting noted in step e, first bullet.
- Press the Trigger Source button to toggle the source to the channel selected.
- Move the test hookup to the channel you selected.
- Press **RUN/STOP** button to start the display.
- Repeat step d.

2. *Disconnect all test equipment from the oscilloscope.*

Trigger System Checks

These procedures check those characteristics that relate to the trigger system and are listed as checked in *Specifications*.

Check Time Accuracy for Pulse, Glitch, Timeout, and Width Triggering

Equipment required	One sine wave generator (Item 12) One 10X attenuator (Item 1) One 50 Ω , precision coaxial cable (Item 4) One SMA male-to-female BNC adapter (Item 19)
Prerequisites	See page 4-17

1. *Install the test hookup and preset the instrument controls:*
 - a. *Initialize the instrument:* Press the **DEFAULT SETUP** button.
 - b. *Modify the default setup:* Set the horizontal **SCALE** to 10 ns.
 - c. *Hook up the test-signal source:* Connect the output of the sine wave generator (Item 12) to CH 1.

Do this through a 50 Ω precision coaxial cable, followed by a 10X attenuator and adapter. See Figure 4-24.

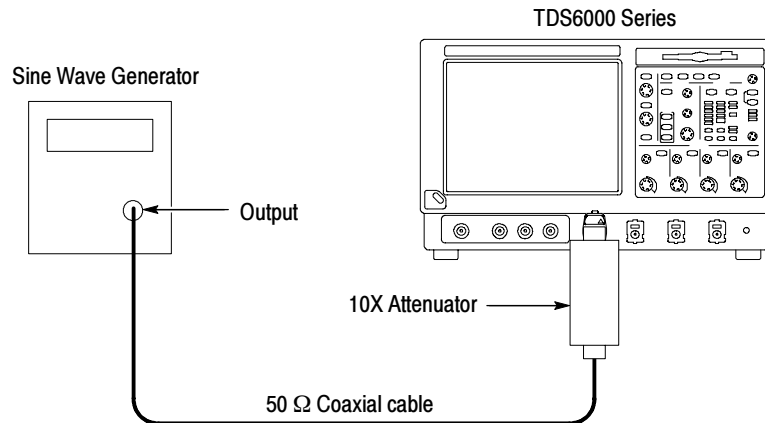

Figure 4-24: Initial test hookup

2. *Confirm the trigger system is within time-accuracy limits for pulse-glitch or pulse-width triggering (time range ≤ 500 ns):*
 - a. *Display the test signal:* Set the output of the sine wave generator for a 100 MHz, five-division sine wave on screen. Press **PUSH TO SET 50%**.
 - b. *Set the trigger mode:* Press the Trigger **MODE** button to toggle it to **NORMAL**.
 - c. *Set upper and lower limits that ensure triggering:* See Figure 4-25.
 - Press the front-panel **ADVANCED** button and select the **A Event** tab; then select width triggering by touching the **Width** button.
 - Touch the **Trig When** button and select **Inside** limits.
 - Touch **Upper Limit** and use the keyboard to set the upper limit to 10 ns: press **10**, then **n**, and **ENTER**.
 - Touch **Lower Limit** and use the keypad to set the lower limit to 2 ns.
 - d. *Change limits until triggering stops:*
 - Press **PUSH TO SET 50%**.
 - While doing the following subparts, monitor the display (it will stop acquiring) and the front-panel light **TRIG'D** (it will extinguish) to determine when triggering is lost.
 - Use the multipurpose knob to *increase* the **Lower Limit** readout until triggering is lost.

- CHECK that the **Lower Limit** readout, after the oscilloscope loses triggering, is within 3.5 ns to 6.5 ns, inclusive.
- Enter the time on the test record.
- Use the keypad to return the **Lower Limit** to 2 ns and reestablish triggering.
- Touch **Upper Limit**; then use the multipurpose knob to slowly *decrease* the **Upper Limit** readout until triggering is lost.
- CHECK that the **Upper Limit** readout, after the oscilloscope loses triggering, is within 3.5 ns to 6.5 ns, inclusive.
- Enter the time on the test record.

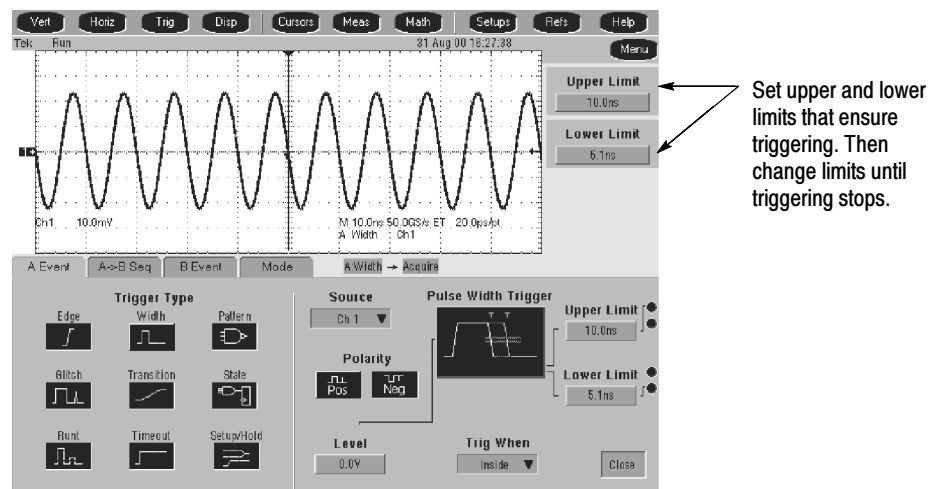

Figure 4-25: Measurement of time accuracy for pulse and glitch triggering

3. *Confirm the trigger system is within time-accuracy limits for pulse-glitch or pulse-width triggering (time range >520 ns):*
 - a. *Set upper and lower limits that ensure triggering at 250 kHz:*
 - Touch **Upper Limit**. Use the keyboard to set the upper limit to 4 μ s.
 - Touch **Lower Limit**. Use the keypad to set the lower limit to 500 ns.
 - b. *Display the test signal:*
 - Set the Horizontal **SCALE** to 4 μ s.

- Set the output of the sine wave generator for a 250 kHz, five-division sine wave on screen. Set the Vertical **SCALE** to 20 mV (the waveform will overdrive the display).
 - Press **PUSH TO SET LEVEL 50%**.
- c. *Check against limits:* Do the following subparts in the order listed.
- Use the multipurpose knob to *increase* the **Lower Limit** readout until triggering is lost.
 - CHECK that the **Lower Limit** readout, after the oscilloscope stops triggering, is within 1.9 μ s to 2.1 μ s, inclusive.
 - Enter the time on the test record.
 - Use the keypad to return the **Lower Limit** to 500 ns and reestablish triggering.
 - Touch **Upper Limit**; then use the multipurpose knob to slowly *decrease* the **Upper Limit** readout until triggering stops.
 - CHECK that the **Upper Limit** readout, after the oscilloscope loses triggering, is within 1.9 μ s to 2.1 μ s, inclusive.
 - Enter the time on the test record.
4. *Disconnect the hookup:* Disconnect the cable and adapter from the generator output and the input connector of **CH 1**.

Check Sensitivity, Edge Trigger, DC Coupled

Equipment required	One sine wave generator (Item 12) Two precision 50 Ω coaxial cables (Item 4) One 10X attenuator (Item 1) One BNC T connector (Item 6) One SMA male-to-female BNC adapter (Item 19) One 5X attenuator (Item 2) One 50 Ω terminator (Item 3)
Prerequisites	See page 4-17.

1. *Install the test hookup and preset the instrument controls:*
- a. *Initialize the oscilloscope:* Press the **DEFAULT SETUP** button.
 - b. *Modify the initialized front-panel control settings:*
 - Set the Horizontal **SCALE** to 20 ns.

- Press the Trigger **MODE** button to toggle it to **Normal**.
 - From the tool bar, touch **Horiz** and select the **Acquisition** tab.
 - Touch **Average** and set the number of averages to **16**.
 - Touch the **Equivalent Time ET** button.
- c. *Hook up the test-signal source:*
- Connect the signal output of the generator to a BNC T connector. Connect one output of the T connector to **CH 1** through a 50 Ω precision coaxial cable and an adapter. Connect the other output of the T connector to a 50 Ω terminator. Connect the terminator to the **AUX INPUT**. See Figure 4-26.

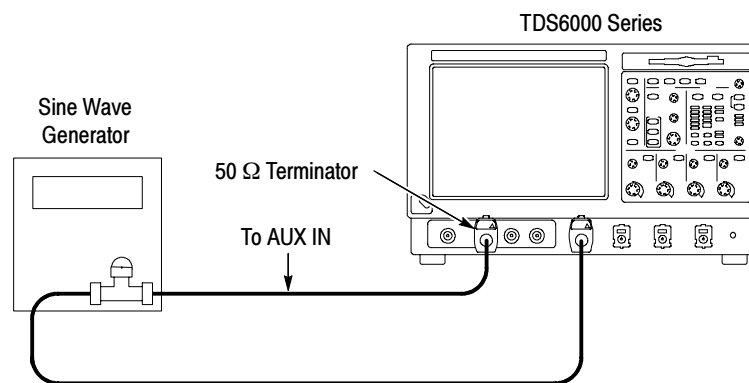

Figure 4-26: Initial test hookup

2. *Confirm the trigger system is within sensitivity limits (50 MHz):*
 - a. *Display the test signal:*
 - Set the generator frequency to 50 MHz.
 - From the button bar, touch **MEAS**.
 - Touch Setup **Ref Levs**; then touch the **Min-Max** button.
 - Touch the **Setup** button and select the **Ampl** tab; then touch the **Amplitude** button.
 - Touch **Close**.
 - Press **PUSH TO SET 50%**.

- Set the test signal amplitude for about three and a half divisions on screen. Now fine adjust the generator output until the **CH 1 Amplitude** readout indicates the amplitude is 350 mV. Readout may fluctuate around 350 mV.
 - Disconnect the 50 Ω precision coaxial cable at **CH 1** and reconnect it to **CH 1** through a 10X attenuator.
- b. *Check the Main trigger system for stable triggering at limits:*
- Read the following definition: A stable trigger is one that is consistent; that is, one that results in a uniform, regular display triggered on the selected slope (positive or negative). This display should *not* have its trigger point switching between opposite slopes, nor should it roll across the screen. At horizontal scale settings of 2 ms/division and faster, **TRIG'D** will remain constantly lighted. It will flash for slower settings.
 - Press the Trigger **Slope** button to select the positive slope.
 - Adjust the Trigger **LEVEL** knob so that there is a stable trigger. CHECK that the trigger is stable for the test waveform on the positive slope.
 - Press the Trigger **Slope** button to select the negative slope. Adjust the Trigger **LEVEL** knob so that there is a stable trigger.
 - CHECK that the trigger is stable for the test waveform on the negative slope.
 - Leave the trigger system triggered on the positive slope of the waveform before continuing to the next step.

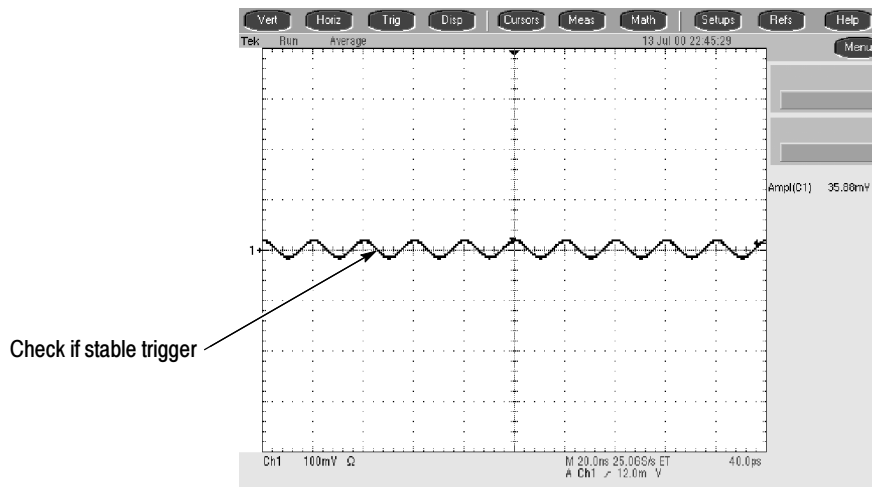

Figure 4-27: Measurement of trigger sensitivity - 50 MHz results shown

- c. *Check Delayed trigger system for stable triggering at limits:* Do the following subparts in the order listed.
- From the button bar touch **Trig**, select the **A Event** tab, and set the **Source** to Line.
 - From the button bar select **Trig**. Select the **A->B Seq** tab, and touch the A then B **Trig After Time** button.
 - Select the **B Event** tab, and touch the **Set 50%** button.
 - CHECK that a stable trigger is obtained for the test waveform for both the positive and negative slopes of the waveform. Use the **TRIGGER LEVEL** knob to stabilize the Main trigger. Touch **B Trig Level** and use the keypad or the multipurpose knob/FINE button to stabilize the Delayed trigger. Touch one of the Slope buttons to switch between trigger slopes. See Figure 4-27 on page 4-69.
 - Leave the Delayed trigger system triggered on the positive slope of the waveform before continuing to the next step. Also, return to the main trigger: select the **A->B Seq** tab and touch the A->B Sequence **A Only** button. Then select the **A Event** tab.
 - Press **Close**.

3. *Confirm the AUX Trigger input:*

a. *Display the test signal:*

- Remove the 10X attenuator and reconnect the cable to **CH 1**.
- Set the signal amplitude as follows:

TDS6404	2.5 divisions
TDS6604	2.5 divisions
TDS6404	2.5 divisions
- Now fine adjust the generator output until the **CH 1 Amplitude** readout indicates the amplitude is as follows (Readout may fluctuate):

TDS6404	250 mV
TDS6604	250 mV
TDS6404	250 mV

b. *Check the AUX trigger source for stable triggering at limits:* Do the following in the order listed.

- Use the definition for stable trigger from step 2b.
- Press the Trigger **SOURCE** button to toggle it to **EXT**.
- Press **PUSH TO SET 50%**.
- **CHECK** that a stable trigger is obtained for the test waveform on both the positive and negative slopes. Press the Trigger **SLOPE** button to switch between trigger slopes. Use the Trigger **LEVEL** knob to stabilize the trigger if required.
- Leave the trigger system triggered on the positive slope of the waveform before proceeding to the next check.
- Press the Trigger **SOURCE** button to toggle it to **CH 1**.

4. *Confirm that the trigger system is within sensitivity limits (full bandwidth):*

a. *Set the Horizontal Scale:* Set the Horizontal **SCALE** to 200 ps.

b. *Display the test signal:*

- Set the generator frequency to full bandwidth as follows:

TDS6404	3 GHz
TDS6604	3 GHz
TDS6404	3 GHz
- Set the test signal amplitude for about seven divisions on screen. Now fine adjust the generator output until the **CH 1 Amplitude**

readout indicates the amplitude is 750 mV. (Readout may fluctuate around 750 mV).

- Disconnect the cable at **CH 1** and reconnect it to **CH 1** through a 5X attenuator. Check that a stable trigger is obtained.
- c. Repeat step 2, substep b for the full bandwidth selected.
- d. *Display the test signal:*
- Set the generator frequency to full bandwidth as follows:

TDS6404	1.5 GHz
TDS6604	1.5 GHz
TDS6404	1.5 GHz
 - Disconnect the 5X attenuator. Set the test signal amplitude for about five divisions on screen. Now fine adjust the generator output until the **CH 1 Amplitude** readout indicates the amplitude is 500 mV. (Readout may fluctuate around 500 mV).
 - Disconnect the cable at **CH 1** and reconnect it to **CH 1** through a 5X attenuator. Check that a stable trigger is obtained.
- e. Repeat step 2, substep c only, for the full bandwidth selected.
- f. *Display the test signal:*
- Set the generator frequency to 500 MHz.
 - Set the Horizontal SCALE to 2.5 ns.
 - Remove the 5X attenuator and reconnect the cable to **CH 1**.
 - Set the generator amplitude on screen as follows:

TDS6404	4 divisions
TDS6604	4 divisions
TDS6404	4 divisions
 - Now fine adjust the generator output until the **CH 1 Amplitude** readout indicates the amplitude is as follows (Readout may fluctuate):

TDS6404	350 mV
TDS6604	350 mV
TDS6404	350 mV
- g. Repeat step 3, substeps b only, for the full bandwidth selected.

NOTE. You just checked the trigger sensitivity. If desired, you may repeat steps 1 through 4c for the other channels (CH 2, CH 3, and CH 4).

5. *Disconnect the hookup:* Disconnect the cables and adapter from AUX IN and the channel last tested.

Output Signal Checks

The procedure that follows checks those characteristics of the output signals that are listed as checked under *Warranted Characteristics* in *Specifications*. The oscilloscope outputs these signals at its front panel.

Check Outputs — CH 3 Signal Out and Aux Trigger Out

Equipment required	Two precision 50 Ω coaxial cables (Item 4) One calibration generator (Item 10) Two SMA male-to-female BNC adapter (Item 19)
Prerequisites	See page 4-17. Also, the oscilloscope must have passed <i>Check DC Voltage Measurement Accuracy</i> on page 4-29.

1. *Install the test hookup and preset the instrument controls:*

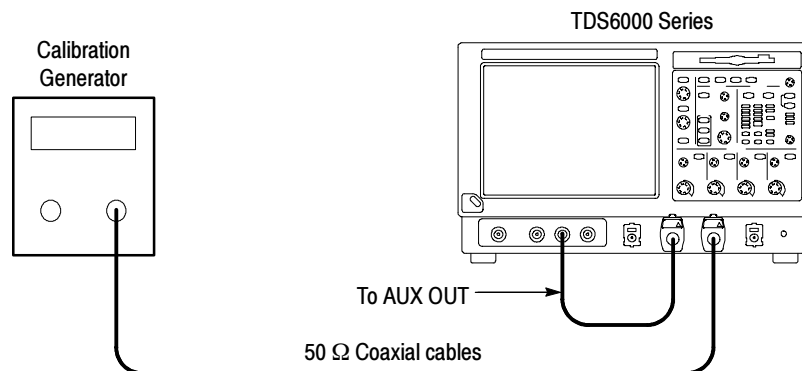

Figure 4-28: Initial test hookup

- a. *Hook up test-signal source 1 (See Figure 4-28):*
 - Connect the standard amplitude output of a calibration generator through a 50 Ω precision coaxial cable to **CH 3** through an adapter.
 - Set the calibration generator to output a 0.500 V square wave.

-
- b. *Hook up test-signal source 2:* Connect the **Aux Out** to **CH 2** through a 50 Ω precision cable and an adapter.
 - c. *Initialize the oscilloscope:* Press the **DEFAULT SETUP** button.
 - d. *Modify the initialized front-panel control settings:*
 - Press the Vertical **CH 1** button to toggle it off.
 - Press the Vertical **CH 3** button to display that channel.
 - Push Trigger **Source** to toggle the source to **CH 3**.
 - Set the Horizontal **SCALE** to 200 μ s.
 - If necessary, adjust the calibration generator output for 5 divisions of amplitude.
 - From the tool bar, touch **Horiz** and select the **Acquisition** tab.
 - Touch **Average** and set the number of averages to **64**.
 - Touch the **Close** button.
2. *Confirm AUX OUT is within limits for logic levels:*
 - a. *Display the test signal:*
 - Press the Vertical **CH 3** button to turn off CH 3.
 - Press the Vertical **CH 2** button to display that channel.
 - Set the Vertical **SCALE** to 500 mV.
 - Use the Vertical **POSITION** knob to center the display on screen.
 - b. *Measure logic levels:*
 - From the button bar, touch **MEAS** and select the **Ampl** tab.
 - Touch the **High** and **Low** buttons.
 - Touch the **Close** button.
 - c. *Check AUX OUT output against limits:* CHECK that the **CH 2 High** readout is ≥ 1.0 volt and that the **CH 2 Low** readout ≤ 0.25 volts. See Figure 4-29.

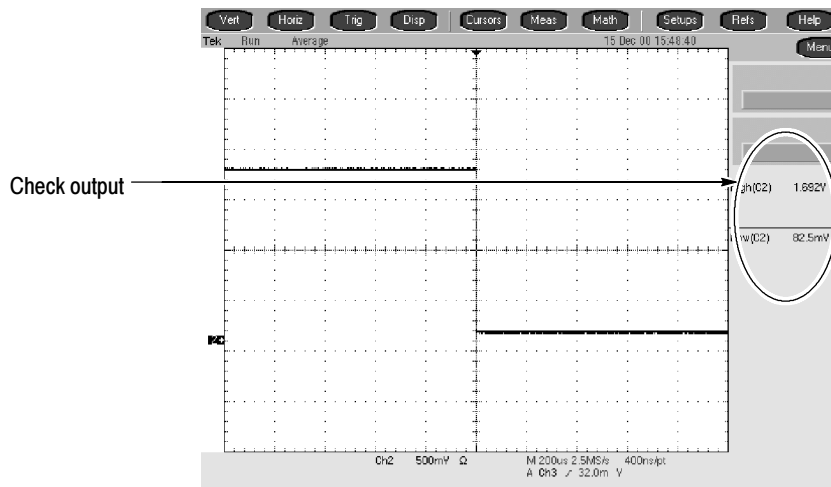

Figure 4-29: Measurement of trigger out limits

3. Confirm SIGNAL OUT is within limits for gain:

a. Measure gain:

- Move the precision 50 Ω cable from the **AUX OUT BNC** to the **SIGNAL OUT BNC**.
- Set Vertical **SCALE** to 50 mV.
- Press **PUSH TO SET 50%**.
- From the button bar, touch **MEAS** and select the **Ampl** tab.
- Touch the **Pk-Pk** button.
- Touch **Close**.

b. Check against limits: CHECK that the readout **CH 2 Pk-Pk** is between 40 mV and 60 mV, inclusive.

4. Confirm SIGNAL OUT is within limits for offset:

- Disconnect the cable from the CH 3 input.
- From the button bar, touch **MEAS** and select the **Ampl** tab.
- Touch the **Low** button.
- Touch **Close**.

a. Check against limits: CHECK that the Low reading is between -100 mV and -170 mV, inclusive.

5. *Disconnect the hookup:* Disconnect the cables and adapters from the inputs and outputs.

Check Probe Compensation Output

Equipment required	Two dual-banana connectors (Item 6) One BNC T connector (Item 7) Two precision 50 Ω coaxial cables (Item 4) One DC calibration generator (Item 9) One SMA-to-BNC adapter (Item 19)
Prerequisites	See page 4-17. Also, the oscilloscope must have passed <i>Check Accuracy For Long-Term Sample Rate and Delay Time Accuracy and Reference</i> on page 4-56.

1. *Install the test hookup and preset the instrument controls:*

a. *Hook up test-signal:*

- Connect one of the 50 Ω cables to **CH 1** through an adapter. See Figure 4-30.
- Connect the other end of the cable just installed to the **PROBE COMPENSATION** output. See Figure 4-30.

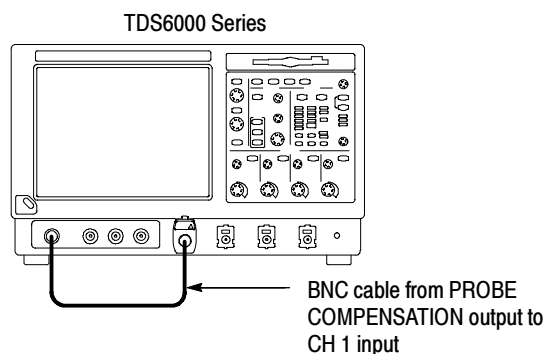

Figure 4-30: Initial test hookup

- b. *Initialize the oscilloscope:* Press the **DEFAULT SETUP** button.
- c. *Modify the initialized front-panel control settings:*
- Set the **Vertical SCALE** to 100 mV.
 - Touch the **Vert** button and then touch **Offset**. Adjust the Ch1 Offset to 0.8 V using the multipurpose knob.

- Set the Horizontal **SCALE** to 200 μ s.
 - Press **PUSH TO SET 50%**.
 - Use the Vertical **POSITION** knob to center the display on screen.
 - From the tool bar, touch **Horiz** and select the **Acquisition** tab.
 - Touch **Average** and set the number of averages to **128**.
2. *Confirm that the Probe Compensator signal is within limits for frequency:*
- a. *Measure the frequency of the probe compensation signal:*
 - From the button bar, touch **MEAS** and select the **Time** tab.
 - Touch the **Freq** button.
 - b. *Check against limits:*
 - CHECK that the **CH 1 Freq** readout is within 950 Hz to 1.050 kHz, inclusive. See Figure 4-31.
 - Enter the frequency on the test record.
 - Touch **Clear** to remove the measurement.

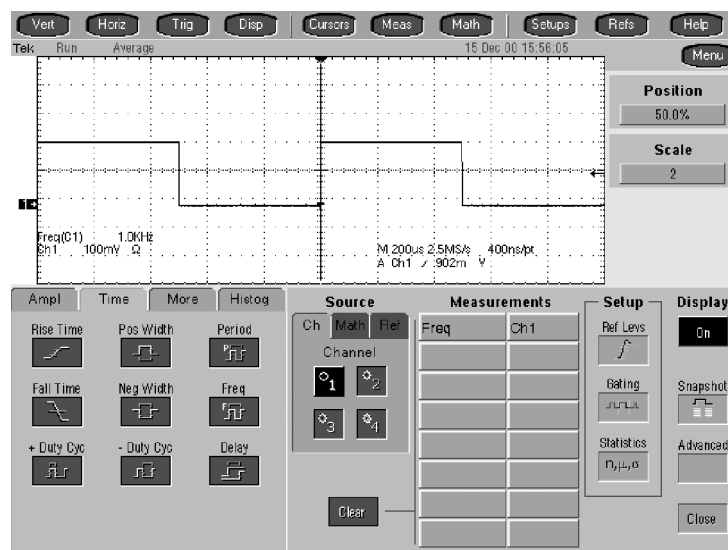

Figure 4-31: Measurement of probe compensator frequency

- c. *Save the probe compensation signal in reference memory:*
 - Touch **Refs**; then select the **Ref 1** tab.

- Touch the **Save Wfm to Ref1 Save** button to save the probe compensation signal in reference 1.
 - Disconnect the cable from **CH 1** and the probe compensation connector.
 - Touch the **Display** button to toggle it to on to displayed the stored signal.
- d. *Hook up the DC standard source:*
- Set the output of a DC calibration generator to off or 0 volts.
 - Connect the output of a DC calibration generator through a dual-banana connector followed by a 50 Ω precision coaxial cable to one side of a BNC T connector. See Figure 4-32.
 - Connect the Sense output of the generator through a second dual-banana connector followed by a 50 Ω precision coaxial cable to the other side of the BNC T connector. Now connect the BNC T connector to **CH 1** through a TCA-BNC or BNC-to-SMA adapter. See Figure 4-32.

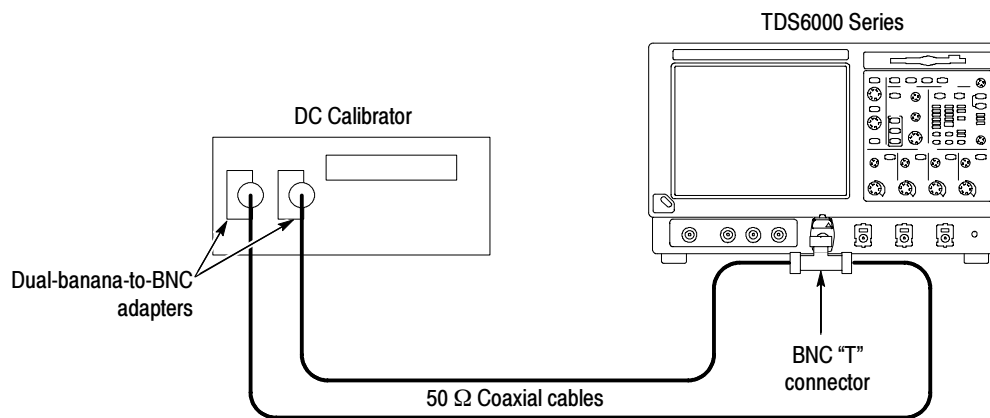

Figure 4-32: Subsequent test hookup

- e. *Measure amplitude of the probe compensation signal:*
- From the tool bar, touch **Horiz** and select the **Acquisition** tab.
 - Touch **Average** and set the number of averages to **16** using the keypad or the multipurpose knob.
 - Adjust the output of the DC calibration generator until it precisely overlaps the top (upper) level of the stored probe compensation signal. (This value will be near 1.0 V).

- Record the setting of the DC generator.
 - Adjust the output of the DC calibration generator until it precisely overlaps the base (lower) level of the stored probe compensation signal. (This value will be near 800 mV).
 - Record the setting of the DC generator.
- f. Press **Close** to remove the menus from the display. See Figure 4-33.

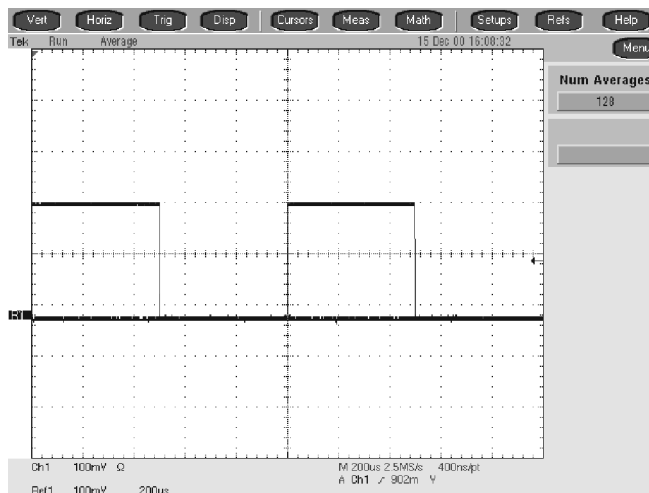

Figure 4-33: Measurement of probe compensator amplitude

- g. *Check against limits:*
- Subtract the value just obtained (base level) from that obtained previously (top level).
 - CHECK that the difference obtained is within 160 mV to 240 mV, inclusive.
 - Enter voltage difference on test record.
3. *Disconnect the hookup:* Disconnect the cable and adapter from **CH 1**.

Serial Trigger Checks (Option ST Only)

These procedures check those characteristics that relate to the serial trigger system and are listed as checked in *Specifications*.

Check Serial Trigger Baud Rate Limits and Word Recognizer Position Accuracy

Equipment required	One precision 50 Ω coaxial cables (Item 4) One sine-wave generator (Item 12) One TCA-BNC or TCA-SMA adapter (item 19)
Prerequisites	See page 4-17. Also, the oscilloscope must have passed <i>Check DC Voltage Measurement Accuracy</i> on page 4-29.

1. *Install the test hookup and preset the instrument controls:*

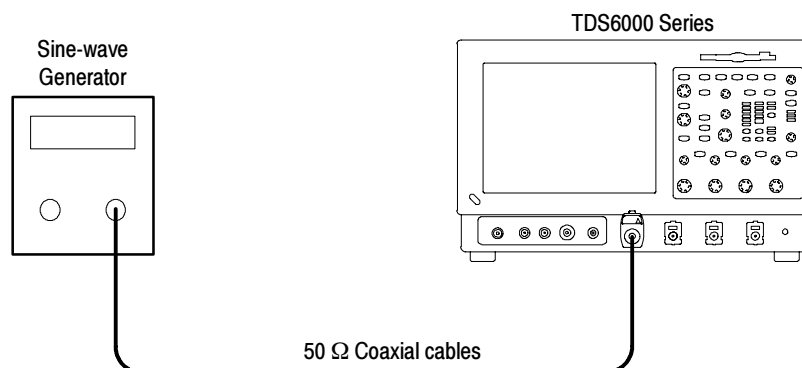

Figure 4-34: Initial test hookup

- a. *Hook Up the test-signal source (see Figure 4-34):*
 - Connect the sine wave output of the sine-wave generator through a 50 Ω precision coaxial cable to CH 1 through an adapter.
 - Set the sine-wave generator to output a 433 MHz sine wave.
- b. *Initialize the instrument:* Press the **DEFAULT SETUP** button.
- c. *Modify the initialized front-panel control settings:*
 - Set the vertical **SCALE** to 50 mV per division.
 - Set the horizontal **SCALE** to 2.5 ns per division.
 - Adjust the sine-wave generator output for 4 divisions of amplitude centered on the display.
 - Adjust the trigger **LEVEL** to trigger at 25% (-1 division) on the sine wave.

Table 4-8: Serial pattern data

Serial pattern data	Trigger location
DB6D B6DB ₁₆	One UI before the 0
B6DB 6DB6 ₁₆	At the 0
6DB6 DB6D ₁₆	One UI after the 0

2. *Verify that the signal path can do isolated 0 and pattern matching circuits can do isolated 1:*
 - a. From the button bar, touch **Cursors** and then the **Setup** button.
 - b. Set the Tracking Mode to **Tracking**.
 - c. Touch the **Close** button.
 - d. Adjust the cursors until the Δt readout equals 800 ps (one unit interval). Center the cursors around the center graticule line (see Figure 4-35).
 - e. From the button bar, touch **Trig** and select the **A Event** tab.
 - f. Touch the **Serial Trigger Type** button and then set the Standard to **GB Ethernet**.
 - g. Touch the **Editor** button.
 - h. Set the Format to **Hex** and then touch the **Clear** button.
 - i. Enter data into the Serial Pattern Data field for one of the settings in Table 4-8 that is not yet checked. (Start with the first setting listed.)
 - j. Touch **Apply**.
 - k. Verify that the instrument triggers one Unit Interval (UI, one baud divided by the bit period) before the 0 in the input signal (see Figure 4-35). Enter pass or fail in the test record.
 - l. Touch the **Clear** button.
 - m. Enter data into Serial Pattern Data field for the next setting in Table 4-8 that is not yet checked.
 - n. Touch **Apply**.
 - o. Verify that the instrument triggers at the 0 in the input signal (see Figure 4-35). Enter pass or fail in the test record.

Triggered 1 UI before a 0

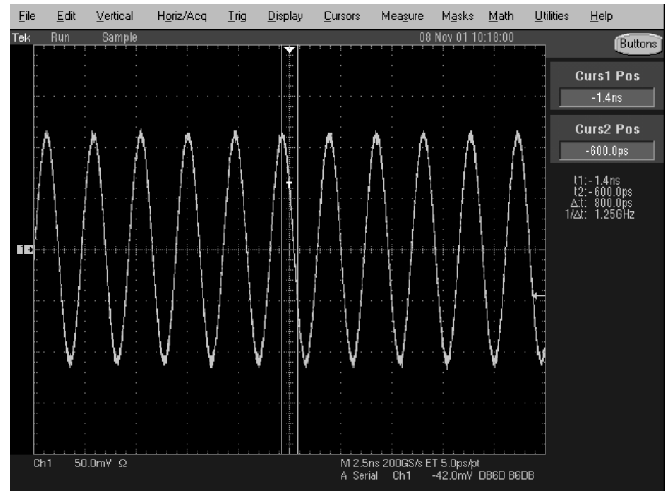

Triggered on a 0

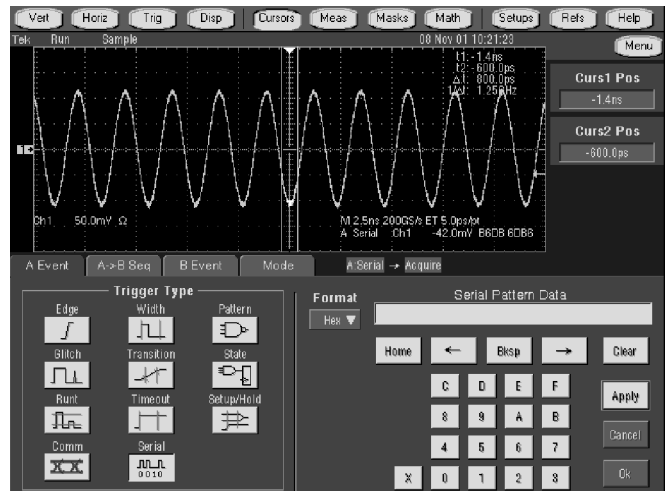

Triggered 1 UI after a 0

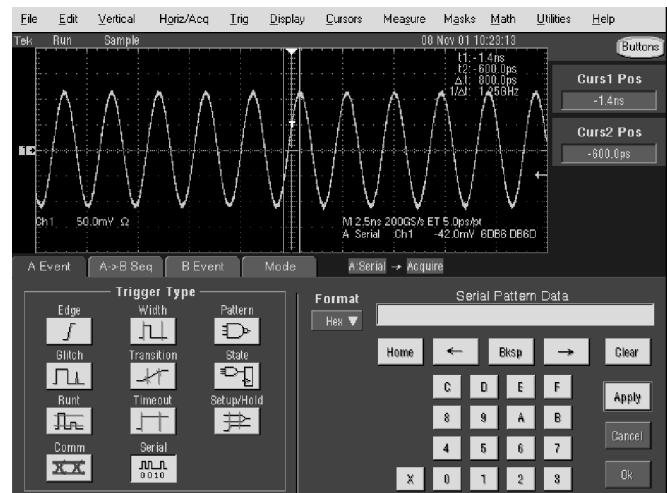

Figure 4-35: Isolated 0 triggering

- p. Touch the **Clear** button.
- q. Enter data into Serial Pattern Data field for the next setting in Table 4-8 that is not yet checked.
- r. Touch **Apply**.
- s. Verify that the instrument triggers one Unit Interval (UI) after the 0 in the input signal (see Figure 4-35). Enter pass or fail in the test record.

Table 4-9: Word recognizer data

Serial pattern data	Trigger location
2492 4924 ₁₆	One UI before the 1
4924 9249 ₁₆	At the 1
9249 2492 ₁₆	One UI after the 1

3. *Verify that the serial path and pattern matching circuits can do isolated 1s:*
 - a. Adjust the trigger **LEVEL** to trigger at 75% (+1 division) on the sine wave.
 - b. Touch the **Clear** button.
 - c. Enter data into the Serial Pattern Data field for one of the settings in Table 4-9 that is not yet checked. (Start with the first setting listed.)
 - d. Touch **Apply**.
 - e. Verify that the instrument triggers one Unit Interval (UI) before the 1 in the input signal (see Figure 4-36). Enter pass or fail in the test record.
 - f. Touch the **Clear** button.
 - g. Enter data into the Serial Pattern Data field for the next setting in Table 4-9 that is not yet checked.
 - h. Touch **Apply**.
 - i. Verify that the instrument triggers at the 1 in the input signal (see Figure 4-36). Enter pass or fail in the test record.
 - j. Touch the **Clear** button.
 - k. Enter data into the Serial Pattern Data field for the next setting in Table 4-9 that is not yet checked.
 - l. Touch **Apply**.

Triggered 1 UI before a 1

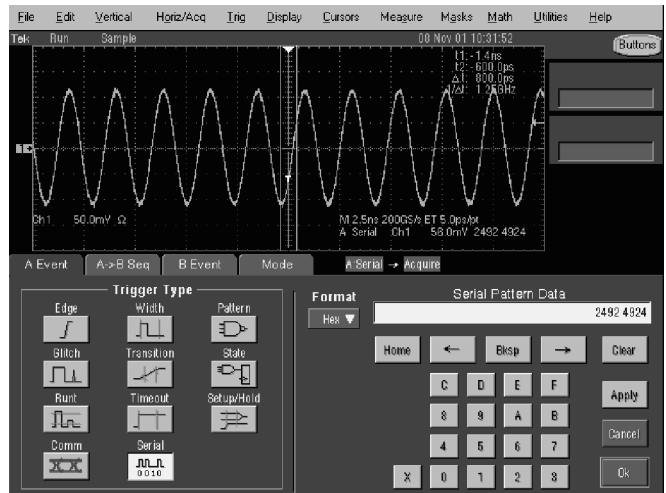

Triggered on a 1

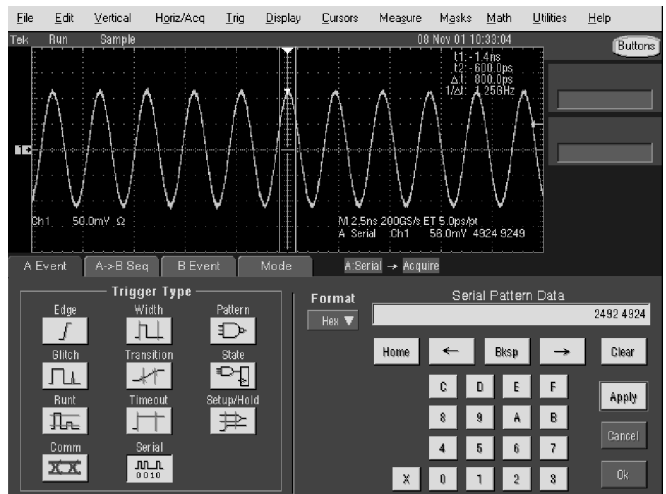

Triggered 1 UI after a 1

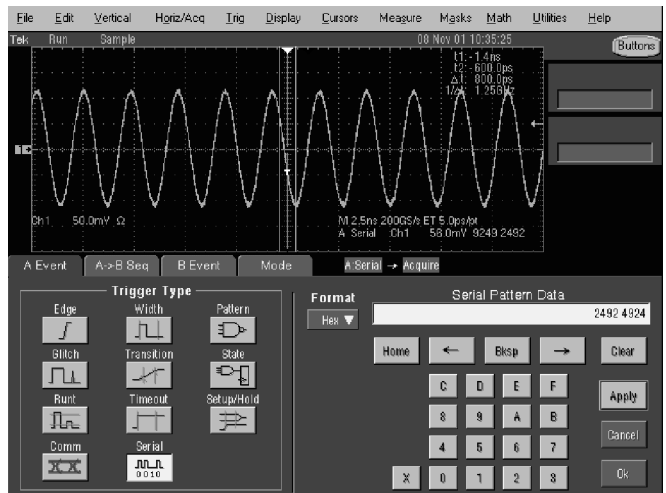
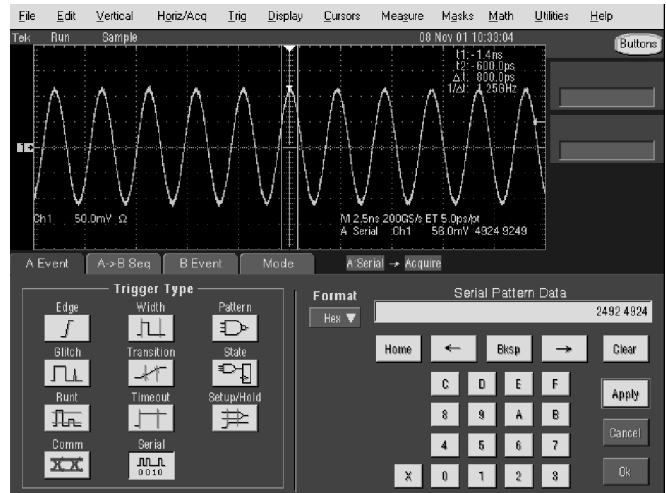
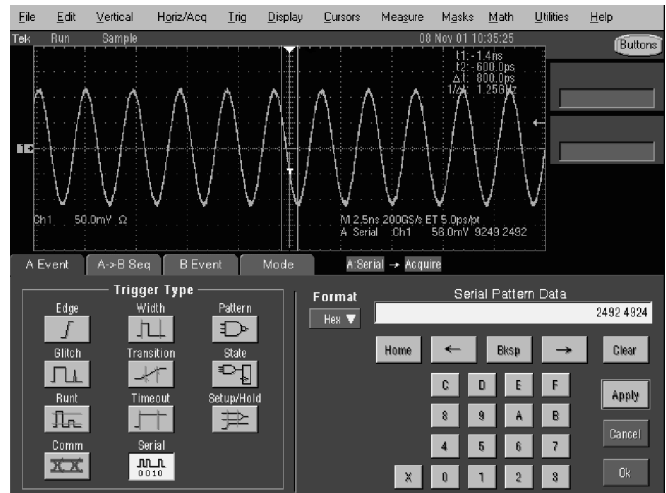

Figure 4-36: Isolated 1 triggering

Triggering on a 1. Step 1, 4, 7, 10, ...



Triggering 1 clock cycle after a 1. Step 2, 5, 8, 11, ...



Triggering 2 clock cycles after a 1. Step 3, 6, 9, 12, ...

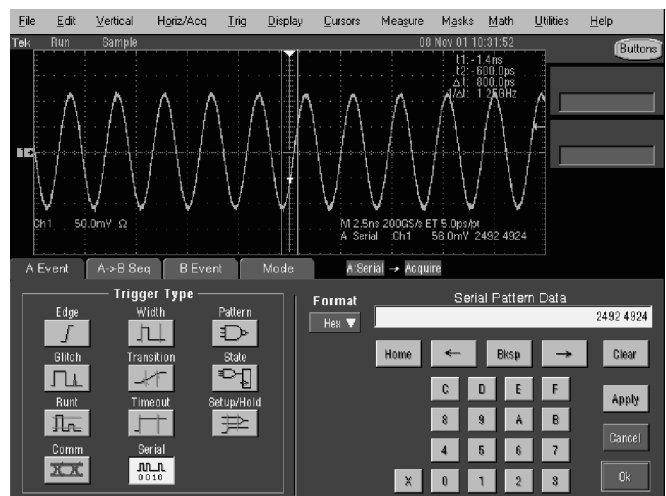
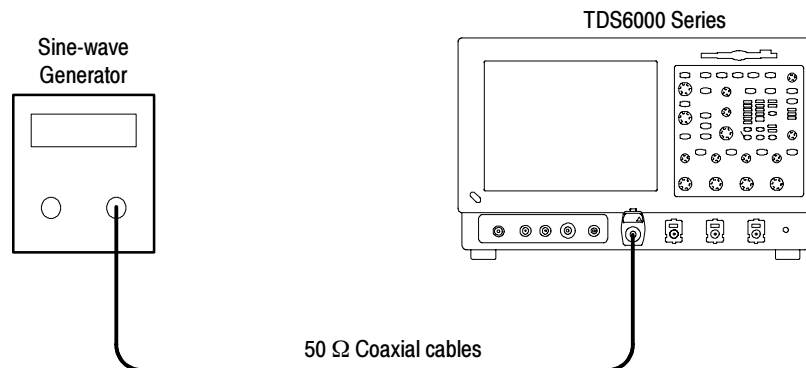

Figure 4-37: N modulo 3 triggering

Check Serial Trigger Clock Recovery Range

Equipment required	One precision 50 Ω coaxial cables (Item 4) One sine wave generator (Item 12) One TCA-BNC or TCA-SMA adapter (item 19)
Prerequisites	See page 4-17. Also, the oscilloscope must have passed <i>Check DC Voltage Measurement Accuracy</i> on page 4-29.

1. Install the test hookup and preset the instrument controls:**Figure 4-38: Initial test hookup**

- a. *Hook up test-signal source 1 (See Figure 4-38):*
 - Connect the sine wave output of the sine wave generator through a 50 Ω precision coaxial cable to CH 1 through an adapter.
 - Set the sine-wave generator to output a 1250 MHz sine wave.
- b. *Initialize the instrument:* Press the **DEFAULT SETUP** button.
- c. *Modify the initialized front-panel control settings:*
 - Press the Vertical **SCALE** to 50 mV per division.
 - Set the horizontal **SCALE** to 500 ps per division.
 - From the button bar, touch the **Disp** button.
 - Touch the Display Style to **Dots**.
 - Touch the Display Persistence to **Variable**, and set the Persist Time to **3.0 s**.
 - Touch the **Close** button.
 - Adjust the sine-wave generator output for 8 divisions of amplitude.

- From the button bar, touch **Trig** and select the **A Event** tab.
 - Touch the **Comm** button. Set **Source** to Ch1, **Type** to R Clk, and **Coding** to NRZ.
2. *Verify the clock recovery at frequency:*
- a. From the button bar, touch **Trig** and select the **A Event** tab.
 - b. Set the sine-wave generator to output one of the input frequencies in Table 4-10 (on page 4-87) that is not yet checked. (Start with the first setting listed.)
 - c. Set the instrument Bit Rate to the Recovered clock Baud rate listed in the table for the current input frequency.

NOTE. *The instrument will attempt to acquire lock once. If the input data is disrupted, removed, or heavily distorted, the instrument may not acquire lock or may lose lock. If the recovered clock is not locked to the incoming data, the waveform display will not be stable (see Figure 4-39). Once the input data is available, press the PUSH SET TO 50% knob to force the instrument to acquire lock again.*

- d. Press **PUSH TO SET 50%**.

NOTE. *As the input frequency is lowered, adjust the Horizontal SCALE to maintain about 3 to 5 eyes across the display.*

- e. Verify that lock is acquired as in Figure 4-39.
 - f. Repeat substeps b through d for each input frequency listed in Table 4-10 (on page 4-87).
 - g. If all tests pass, enter passed in the test record.
3. *Disconnect the hookup:* Disconnect the cables and adapters from the inputs and outputs.

Table 4-10: Clock recovery input frequencies and baud rates

Input frequency	Recovered clock Baud rate
1250 MHz	2500 Mbaud
625 MHz	2500 Mbaud
625 MHz	2375 Mbaud
594 MHz	2500 Mbaud

Table 4- 10: Clock recovery input frequencies and baud rates (Cont.)

Input frequency	Recovered clock Baud rate
477.5 MHz	1950 Mbaud
462.5 MHz	1850 Mbaud
462.5 MHz	1757 Mbaud
439 MHz	1850 Mbaud
312.5 MHz	1250 Mbaud
310 MHz	1240 Mbaud
155 MHz	620 Mbaud
155 MHz	579 Mbaud
147 MHz	620 Mbaud
109 MHz,	462 Mbaud
115 MHz	439 Mbaud
77.5 MHz	310 Mbaud
39 MHz	156 Mbaud
19.5 MHz	78 Mbaud
9.75 MHz	39 Mbaud
4.875 MHz	19.5 Mbaud
2.438 MHz	9.75 Mbaud
1.219 MHz	4.876 Mbaud
609.5 kHz	2.438 Mbaud
304.8 kHz	1.219 Mbaud

Recovered clock locked
(1250 MHz)

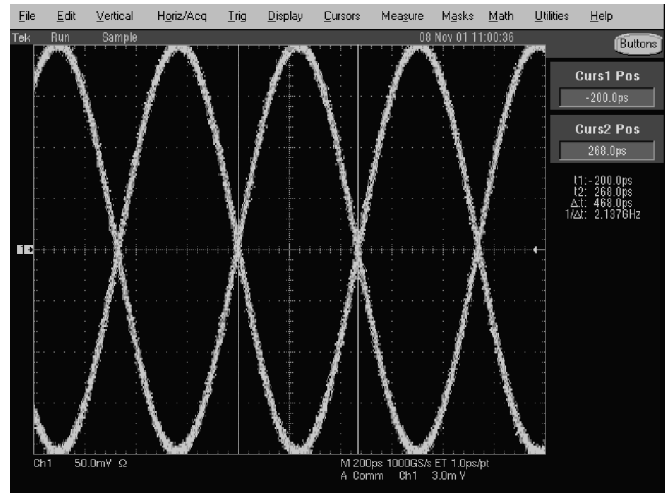

Recovered clock locked
(625 MHz through 304.8 kHz)

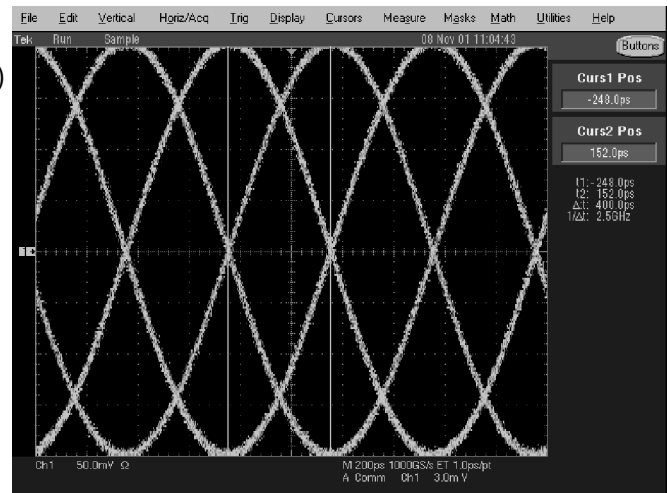

A possible display with the
recovered clock not locked

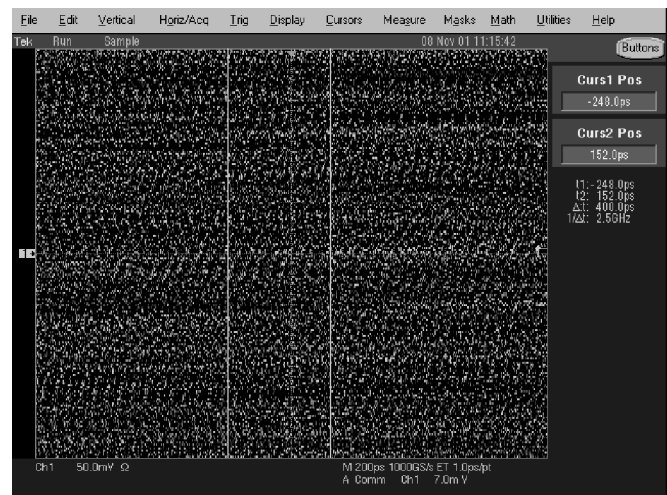

Figure 4-39: Clock recovery

Sine Wave Generator Leveling Procedure

Some procedures in this manual require a sine wave generator to produce the necessary test signals. If you do not have a leveled sine wave generator, use one of the following procedures to level the output amplitude of your sine wave generator.

Equipment required	Sine wave generator (Item 12) Level meter and power sensor (Item 13) Power divider (Item 14) Two male N to female BNC adapters (Item 15) One precision coaxial cable (Item 4) One or two SMA male-to-female BNC adapter (Item 19)
Prerequisites	See page 4-17

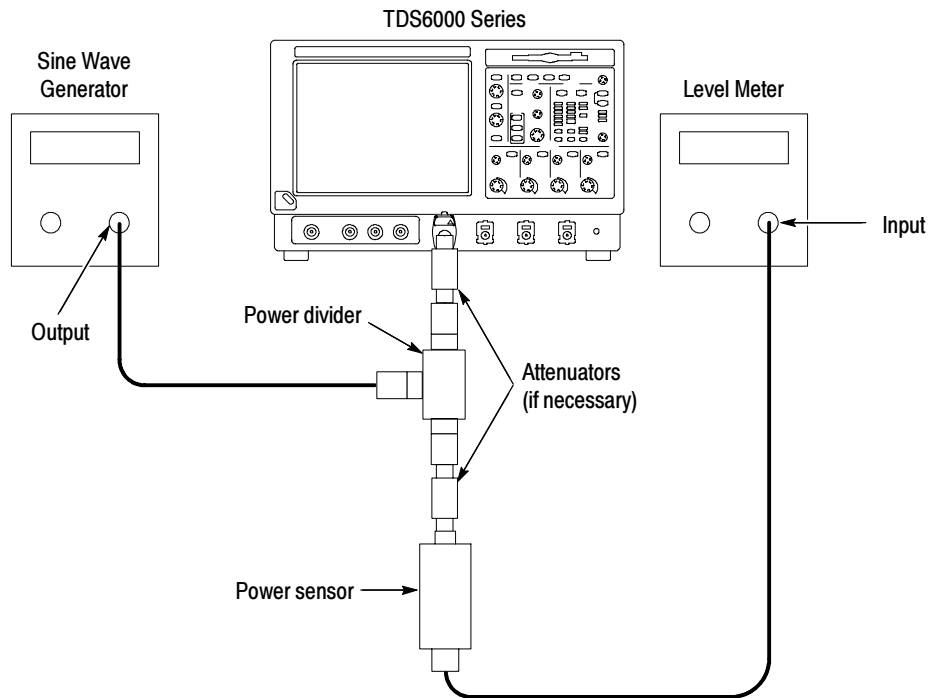

Figure 4-40: Sine wave generator leveling equipment setup

1. *Install the test hookup:* Connect the equipment as shown in Figure 4-40.

2. *Set the Generator:*
 - Set the sine wave generator to a reference frequency of 10 MHz.
 - Adjust the sine wave generator amplitude to the required number of divisions as measured by the oscilloscope.
3. *Record the reference level:* Note the reading on the level meter.
4. *Set the generator to the new frequency and reference level:*
 - Change the sine wave generator to the desired new frequency.
 - Input the correction factor and/or the new frequency into the level meter.
 - Adjust the sine wave generator amplitude until the level meter again reads the value noted in step 3. The signal amplitude is now correctly set for the new frequency.

Equipment required	Sine wave generator (Item 12) Level meter and power sensor (Item 13) Two male N to female BNC adapters (Item 15) Two precision coaxial cables (Item 4) One or two SMA male-to-female BNC adapter (Item 19)
Prerequisites	See page 4-17

1. *Install the test hookup:* Connect the equipment as shown in Figure 4-41 (start with the sine wave generator connected to the oscilloscope).
2. *Set the Generator:*
 - Set the sine wave generator to a reference frequency of 10 MHz.
 - Adjust the sine wave generator amplitude to the required number of divisions as measured by the oscilloscope.

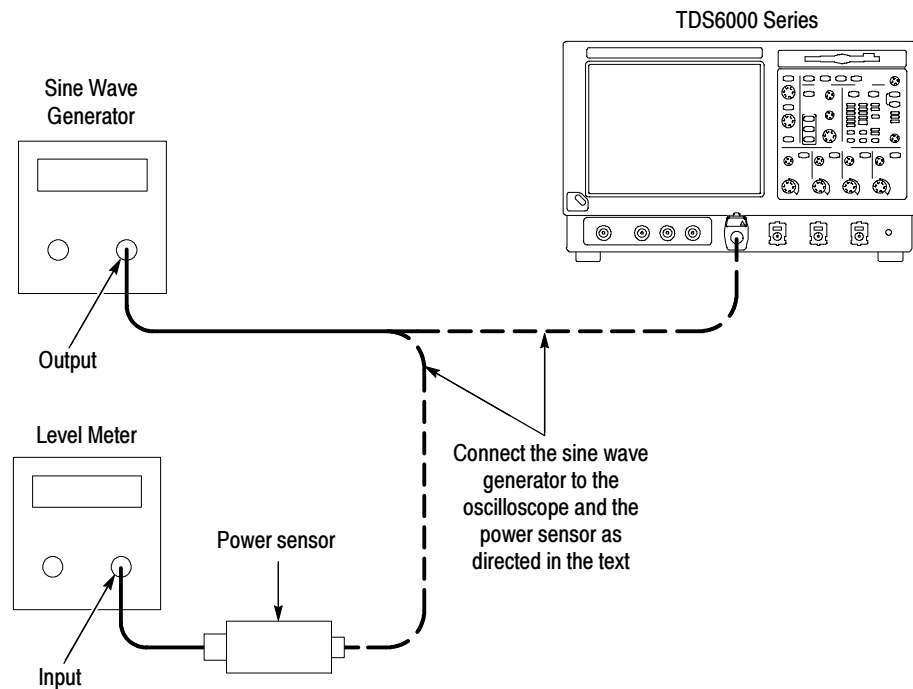

Figure 4-41: Equipment setup for maximum amplitude

3. Record the reference level:

- Disconnect the sine wave generator from the oscilloscope.
- Connect the sine wave generator to the power sensor.
- Note the level meter reading.

4. Set the generator to the new frequency and reference level:

- Change the sine wave generator to the desired new frequency.
- Input the correction factor and/or the new frequency into the level meter.
- Adjust the sine wave generator amplitude until the level meter again reads the value noted in step 3. The signal amplitude is now correctly set for the new frequency.
- Disconnect the sine wave generator from the power sensor.
- Connect the sine wave generator to the oscilloscope.

Adjustment Procedures

This chapter contains adjustment information for your oscilloscope.

Adjustment Interval

The voltage and timing references inside the oscilloscope are very stable over time and should not need routine adjustment.

If the instrument fails performance tests (refer to *Performance Tests* on page 4-17) then adjustment may be required.

If periodic calibration is one of your requirements, a general rule is to verify performance and make adjustments (only if needed) every 2000 hours of operation or once a year if the oscilloscope is used infrequently.

Adjustment After Repair

After removal and replacement of a module due to electrical failure, you must either perform an adjustment or not, depending on the module replaced. Modules listed as customer replaceable have adjustment listed if required. Modules not listed as customer replaceable must be installed and adjusted by Tektronix. See Table 6-7 on page 6-64.

Adjustment

If your instrument requires adjustment, adjustment must be performed by a Tektronix Service Center. See *Contacting Tektronix* on page xvi for information on contacting Tektronix Service Support.

Maintenance

This section contains the information needed to do periodic and corrective maintenance on the oscilloscope. The following subsections are included:

- **Preventing ESD** — General information on preventing damage by electrostatic discharge.
- *Inspection and Cleaning* — Information and procedures for inspecting the oscilloscope and cleaning its external and internal modules.
- *Removal and Installation Procedures* — Procedures for the removal of defective modules and replacement of new or repaired modules. Also included is a procedure for disassembly of the oscilloscope for cleaning.
- *Troubleshooting* — Information for isolating failed modules. Included are instructions for operating the oscilloscope diagnostic routines and troubleshooting trees. Most of the trees make use of the internal diagnostic routines to speed fault isolation to a module.
- **Repackaging Instructions** — Information on returning an oscilloscope for service.

Preventing ESD

Before servicing this product, read the *Safety Summary* and *Introduction* at the front of the manual and the ESD information below.



CAUTION. *Static discharge can damage any semiconductor component in this oscilloscope.*

When performing any service which requires internal access to the oscilloscope, adhere to the following precautions to avoid damaging internal modules and their components due to electrostatic discharge (ESD).

1. Minimize handling of static-sensitive circuit boards and components.
2. Transport and store static-sensitive modules in their static protected containers or on a metal rail. Label any package that contains static-sensitive boards.
3. Discharge the static voltage from your body by wearing a grounded antistatic wrist strap while handling these modules. Do service of static-sensitive modules only at a static-free work station.

4. Nothing capable of generating or holding a static charge should be allowed on the work station surface.
5. Handle circuit boards by the edges when possible.
6. Do not slide the circuit boards over any surface.
7. Avoid handling circuit boards in areas that have a floor or work-surface covering capable of generating a static charge.

Inspection and Cleaning

Inspection and Cleaning describes how to inspect for dirt and damage. It also describes how to clean the exterior and interior of the oscilloscope. Inspection and cleaning are done as preventive maintenance. Preventive maintenance, when done regularly, may prevent oscilloscope malfunction and enhance its reliability.

Preventive maintenance consists of visually inspecting and cleaning the oscilloscope and using general care when operating it.

How often to do maintenance depends on the severity of the environment in which the oscilloscope is used. A proper time to perform preventive maintenance is just before oscilloscope adjustment.

General Care

The cabinet helps keep dust out of the oscilloscope and should normally be in place when operating the oscilloscope.

Interior Cleaning

Use a dry, low-velocity stream of air to clean the interior of the chassis. Use a soft-bristle, non-static-producing brush for cleaning around components. If you must use a liquid for minor interior cleaning, use a 75% isopropyl alcohol solution and rinse with deionized water.



WARNING. *Before performing any procedure that follows, power down the instrument and disconnect it from line voltage.*

Exterior Cleaning

Clean the exterior surfaces of the chassis with a dry lint-free cloth or a soft-bristle brush. If any dirt remains, use a cloth or swab dipped in a 75% isopropyl alcohol solution. Use a swab to clean narrow spaces around controls and connectors. Do not use abrasive compounds on any part of the chassis that may damage the chassis.

Clean the On/Standby switch using a dampened cleaning towel. Do not spray or wet the switch directly.



CAUTION. Avoid the use of chemical cleaning agents which might damage the plastics used in this oscilloscope. Use only deionized water when cleaning the menu buttons or front-panel buttons. Use a 75% isopropyl alcohol solution as a cleaner and rinse with deionized water. Before using any other type of cleaner, consult your Tektronix Service Center or representative.

Inspection — Exterior. Inspect the outside of the oscilloscope for damage, wear, and missing parts, using Table 6-1 as a guide. Immediately repair defects that could cause personal injury or lead to further damage to the oscilloscope.

Table 6-1: External inspection check list

Item	Inspect for	Repair action
Cabinet, front panel, and cover	Cracks, scratches, deformations, damaged hardware	Repair or replace defective module
Front-panel knobs	Missing, damaged, or loose knobs	Repair or replace missing or defective knobs
Connectors	Broken shells, cracked insulation, and deformed contacts. Dirt in connectors	Repair or replace defective modules. Clear or wash out dirt
Carrying handle, and cabinet feet	Correct operation	Repair or replace defective module
Accessories	Missing items or parts of items, bent pins, broken or frayed cables, and damaged connectors	Repair or replace damaged or missing items, frayed cables, and defective modules

Flat Panel Display Cleaning

The display is a soft plastic display and must be treated with care during cleaning.



CAUTION. Improper cleaning agents or methods can damage the flat panel display.
 Avoid using abrasive cleaners or commercial glass cleaners to clean the display surface.
 Avoid spraying liquids directly on the display surface.
 Avoid scrubbing the display with excessive force.

Clean the flat panel display surface by gently rubbing the display with a clean-room wipe (such as Wypall Medium Duty Wipes, #05701, available from Kimberly-Clark Corporation).

If the display is very dirty, moisten the wipe with distilled water or a 75% isopropyl alcohol solution and gently rub the display surface. Avoid using excess force or you may damage the plastic display surface.



CAUTION. To prevent getting moisture inside the oscilloscope during external cleaning, use only enough liquid to dampen the cloth or applicator.

Inspection — Interior. To access the inside of the oscilloscope for inspection and cleaning, refer to the *Removal and Installation Procedures* in this section.

Inspect the internal portions of the oscilloscope for damage and wear, using Table 6-2 as a guide. Defects found should be repaired immediately.

If any circuit board is replaced, check Table 6-2 in Section 5 to see if it is necessary to adjust the oscilloscope.



CAUTION. To prevent damage from electrical arcing, ensure that circuit boards and components are dry before applying power to the oscilloscope.

Table 6-2: Internal inspection check list

Item	Inspect for	Repair action
Circuit boards	Loose, broken, or corroded solder connections. Burned circuit boards. Burned, broken, or cracked circuit-run plating.	Remove and replace damaged circuit board.
Resistors	Burned, cracked, broken, blistered condition.	Remove and replace damaged circuit board.
Solder connections	Cold solder or rosin joints.	Resolder joint and clean with isopropyl alcohol.
Capacitors	Damaged or leaking cases. Corroded solder on leads or terminals.	Remove and replace damaged circuit board.
Semiconductors	Loosely inserted in sockets. Distorted pins.	Firmly seat loose semiconductors. Remove devices that have distorted pins. Carefully straighten pins (as required to fit the socket), using long-nose pliers, and reinsert firmly. Ensure that straightening action does not crack pins, causing them to break off.

Table 6-2: Internal inspection check list (Cont.)

Item	Inspect for	Repair action
Wiring and cables	Loose plugs or connectors. Burned, broken, or frayed wiring.	Firmly seat connectors. Repair or replace modules with defective wires or cables.
Chassis	Dents, deformations, and damaged hardware.	Straighten, repair, or replace defective hardware.

Cleaning Procedure — Interior. To clean the oscilloscope interior, do the following steps:

1. Blow off dust with dry, low-pressure, deionized air (approximately 9 psi).
2. Remove any remaining dust with a lint-free cloth dampened in isopropyl alcohol (75% solution) and rinse with warm deionized water. (A cotton-tipped applicator is useful for cleaning in narrow spaces and on circuit boards.)

STOP. *If, after doing steps 1 and 2, a module is clean upon inspection, skip the remaining steps.*

3. If steps 1 and 2 do not remove all the dust or dirt, the oscilloscope may be spray washed using a solution of 75% isopropyl alcohol by doing steps 4 through 8.
4. Gain access to the parts to be cleaned by removing easily accessible shields and panels (see *Removal and Installation Procedures*).
5. Spray wash dirty parts with the isopropyl alcohol and wait 60 seconds for the majority of the alcohol to evaporate.
6. Use hot (120 °F to 140 °F) deionized water to thoroughly rinse them.
7. Dry all parts with low-pressure, deionized air.
8. Dry all components and assemblies in an oven or drying compartment using low-temperature (125 °F to 150 °F) circulating air.

Lubrication. There is no periodic lubrication required for this oscilloscope.

Removal and Installation Procedures

This subsection contains procedures for removal and installation of all mechanical and electrical modules.

Preparation



WARNING. Before doing this or any other procedure in this manual, read the Safety Summary found at the beginning of this manual. Also, to prevent possible injury to service personnel or damage to the oscilloscope components, read Installation in Section 2, and Preventing ESD in this section.

This subsection contains the following items:

- This preparatory information that you need to properly do the procedures that follow.
- List of tools required to remove all modules.
- Procedures for removal and reinstallation of the electrical and mechanical modules.
- A disassembly procedure for removal of all the major modules from the oscilloscope at one time and for reassembly of those modules into the oscilloscope. Instructions for doing the actual cleaning are found under *Inspection and Cleaning* at the beginning of this section.



WARNING. Before doing any procedure in this subsection, disconnect the power cord from the line voltage source. Failure to do so could cause serious injury or death.

NOTE. Read Equipment Required for a list of the tools needed to remove and install modules in this oscilloscope. See Table 6-3, page 6-8. Read the cleaning procedure before disassembling the oscilloscope for cleaning.

Equipment Required. Most modules in the TDS6000 Digital Storage Oscilloscope can be removed with a screwdriver handle mounted with a size T-15, Torx® screwdriver tip. *Use this tool whenever a procedure step instructs you to remove or install a screw unless a different size screwdriver is specified in that step.* All equipment required to remove and reinstall each module is listed in the first step of its procedure.

Table 6-3: Tools required for module removal

Item no.	Name	Description	General tool number
1	Screwdriver handle	Accepts Torx-driver bits	620-440
2	T-10 Torx tip	Used for removing the electrical or optical module chassis. Torx-driver bit for T-10 size screw heads	640-235
3	T-15 Torx tip	Used for removing most oscilloscope screws. Torx-driver bit for T-15 size screw heads	640-247
4	1/8 inch flat-bladed screwdriver	Screwdriver for unlocking cable connectors	Standard tool
5	#0 phillips screwdriver	Screwdriver for removing small phillips screws, CD, floppy & hard drive	Standard tool
6	Angle-Tip Tweezers	Used to remove front panel knobs	Standard tool
7	3/16 inch open-end wrench	Used to remove the rear panel nut posts	Standard tool
8	5/16 inch open-end wrench	Used to remove the rear panel nut posts	Standard tool
9	MA-800G Soldering Aid	Used to remove the front panel trim	Standard tool

Procedures for External Modules

The following procedures are found here and are listed in order presented.

- Front Panel Knobs
- Trim (all)
- Bottom cover
- Left and Right covers
- Line Fuse and Line Cord

Front-Panel Knobs

1. *Assemble equipment and locate modules to be removed:*
2. *Orient the oscilloscope:* Set the oscilloscope so its bottom is down on the work surface and its front is facing you.
3. *Remove the knob(s):* Grasp any knob you want to remove and pull it straight out from the front panel $\frac{1}{4}$ inch to create some clearance between the base of the knob and the front panel. Insert the angled-tip tweezers between the knob and front panel and use them to remove the knob. See Figure 6-1.
4. *Reinstallation:* To reinstall, align knob to shaft and push it in until it snaps.



CAUTION. To prevent damage to the encoders located on the circuit board, apply pressure to the encoders while pushing the knob on the shaft.

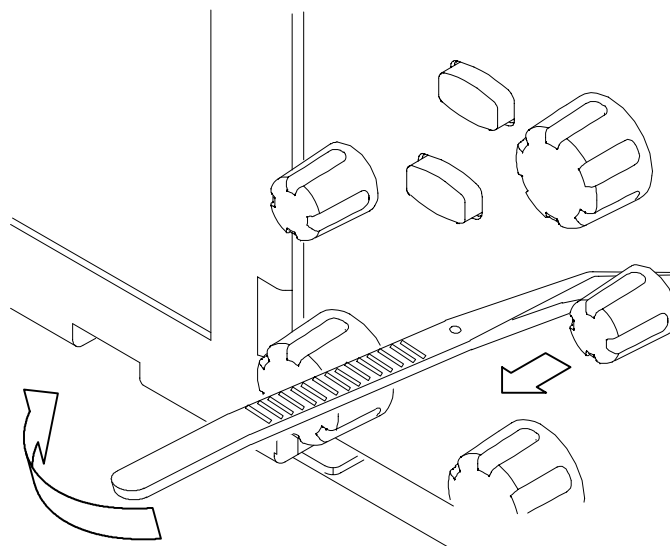

Figure 6-1: Knob removal

Trim and Carrying Handle

1. *Locate module to be removed:* Locate the Trim in the locator diagram. See Figure 6-7, page 6-18.
2. *Remove the front panel trim:* Use Figure 6-2, page 6-11, as a guide.
 - a. To prevent the power button from falling out of the front panel trim, place a piece of tape over the button.
 - b. Grasp the trim ring by its top edge and pull toward you to detach the three plastic snaps. (Alternatively, you can use a flat-bladed screwdriver or other small prying tool to help you detach the snaps.)
 - c. Swing the bottom of the ring upward and off the front panel.
3. *Remove the acquisition trim:* Use Figure 6-2, page 6-11 as a guide.
 - a. Remove the three T-15 Torx screws that secure the acquisition trim to the oscilloscope.
 - b. Remove the acquisition trim from the oscilloscope.
4. *Remove the top cover trim:* Use Figure 6-2, page 6-11 as a guide.
 - a. Remove the accessory pouch; it snaps off.
 - b. Remove the four T-15 Torx screws that secure the top cover trim to the oscilloscope. The T-15 Torx screws also secure the snap studs to the top cover.
 - c. Remove the top cover trim from the oscilloscope.
5. *Remove the carrying handle and the right/left side trim panels:* Use Figure 6-2, page 6-11 as a guide.
 - a. Remove the T-15 Torx screws that secure the handle to the oscilloscope. Remove the handle from the oscilloscope.
 - b. Slide the side trim panels towards the rear of the oscilloscope allowing the tabs to clear the cover openings, then pull out to remove the panels from the oscilloscope.
6. *Reinstallation:* Do in reverse steps 2 through 5 to reinstall the appropriate trim.

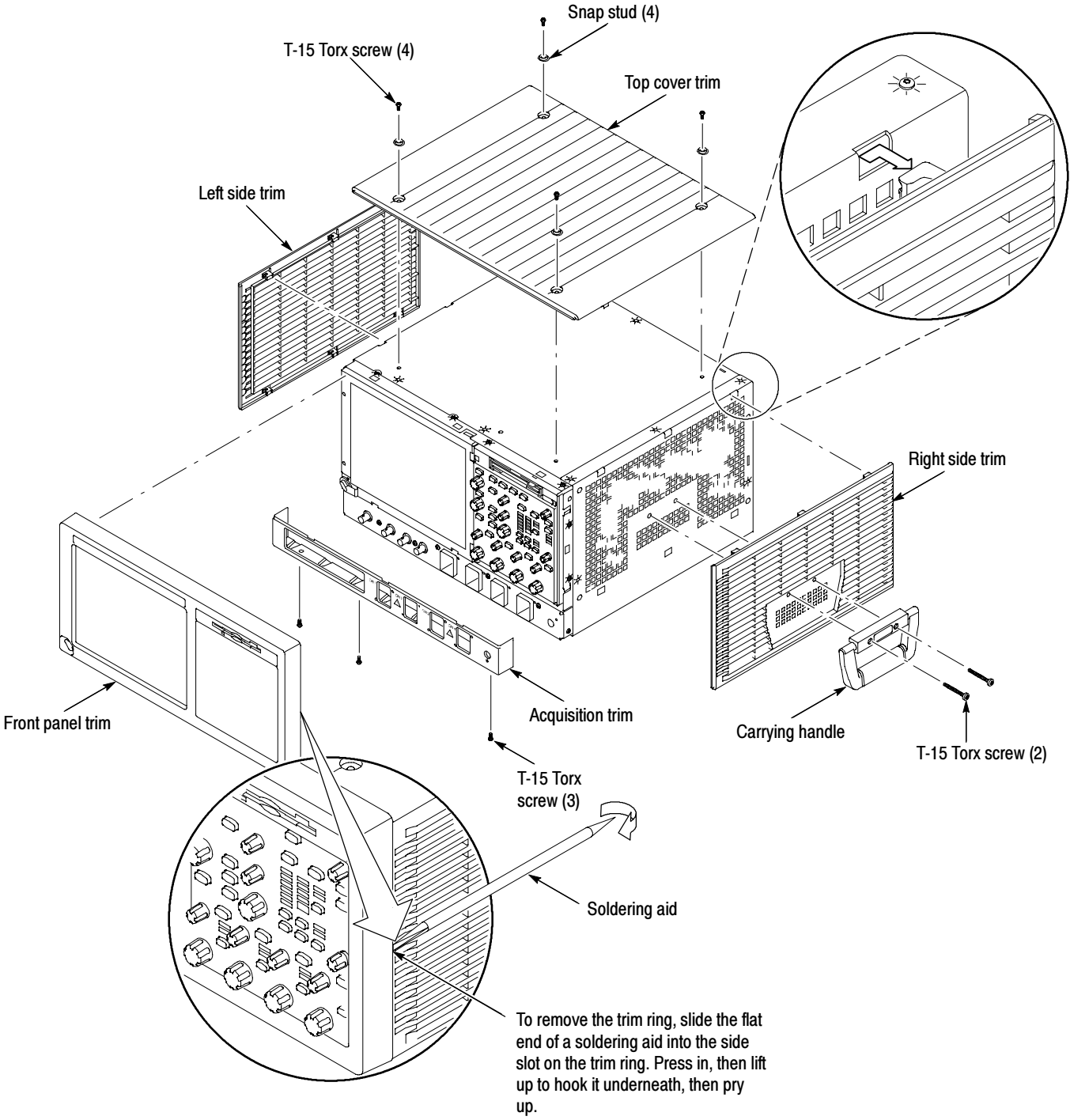

Figure 6-2: Trim removal

- Bottom Cover** 1. Remove the bottom cover: See Figure 6-3, page 6-12.

2. *Orient the oscilloscope:* Set the oscilloscope so its top is down on the work surface and its bottom is facing you.
 - a. Remove the four T-15 Torx screws that secure the bottom cover to the oscilloscope.
 - b. Remove the bottom cover from the oscilloscope.
3. *Reinstallation:* Do in reverse steps a and b to reinstall the bottom cover.

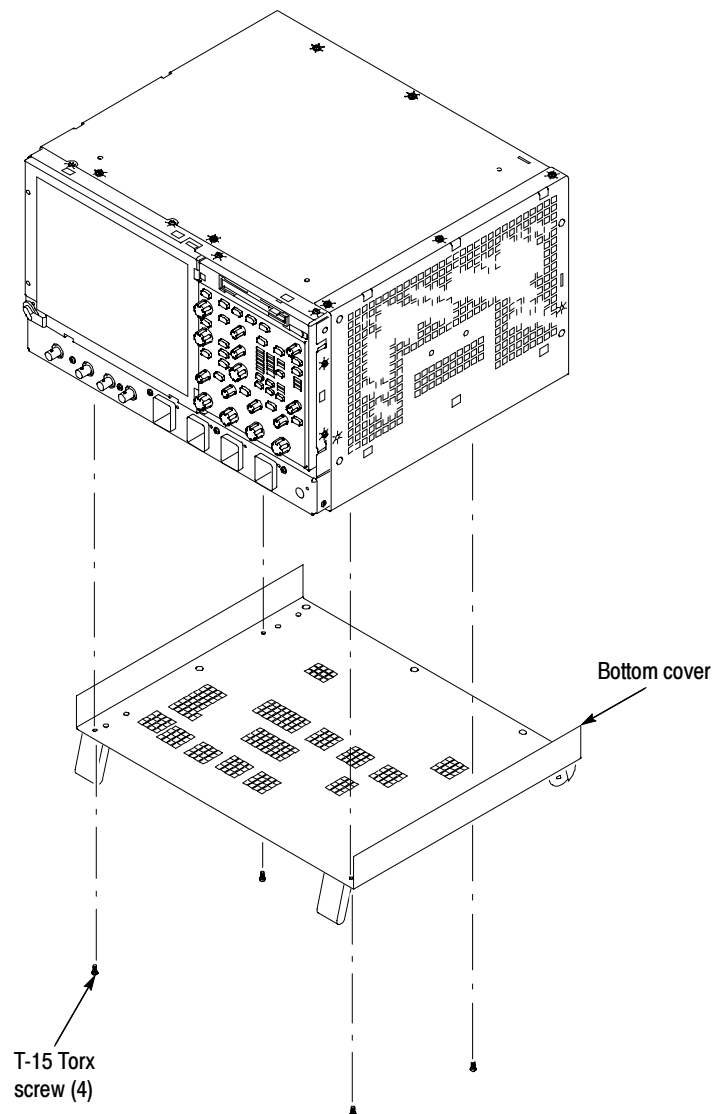

Figure 6-3: Bottom cover removal

- Covers**
1. *Remove the left and right covers:* See Figures 6-4 and 6-5, pages 6-14 and 6-15.
 - Trim (all)
 - Bottom cover
 2. *Orient the oscilloscope:* Set the oscilloscope so its rear is on the work surface and the front of the oscilloscope facing you.

NOTE. *All mounting screw holes are indicated by a star etched around the mounting hole.*

- a. Remove the eleven T-15 Torx screws that secure the covers to the top and both sides of the chassis.
- b. Remove the seven T-15 Torx screws that secure the covers to the bottom of the chassis.
- c. Pull the bottom-right cover down and slide to the right to remove from the oscilloscope. Pull the top-left cover upward and slide to the left to remove from the oscilloscope.



CAUTION. *Take care not to bind or snag the covers on the oscilloscope internal cabling as you remove or install.*

3. *Reinstallation:* Do in reverse steps a through c to reinstall the cabinet covers.

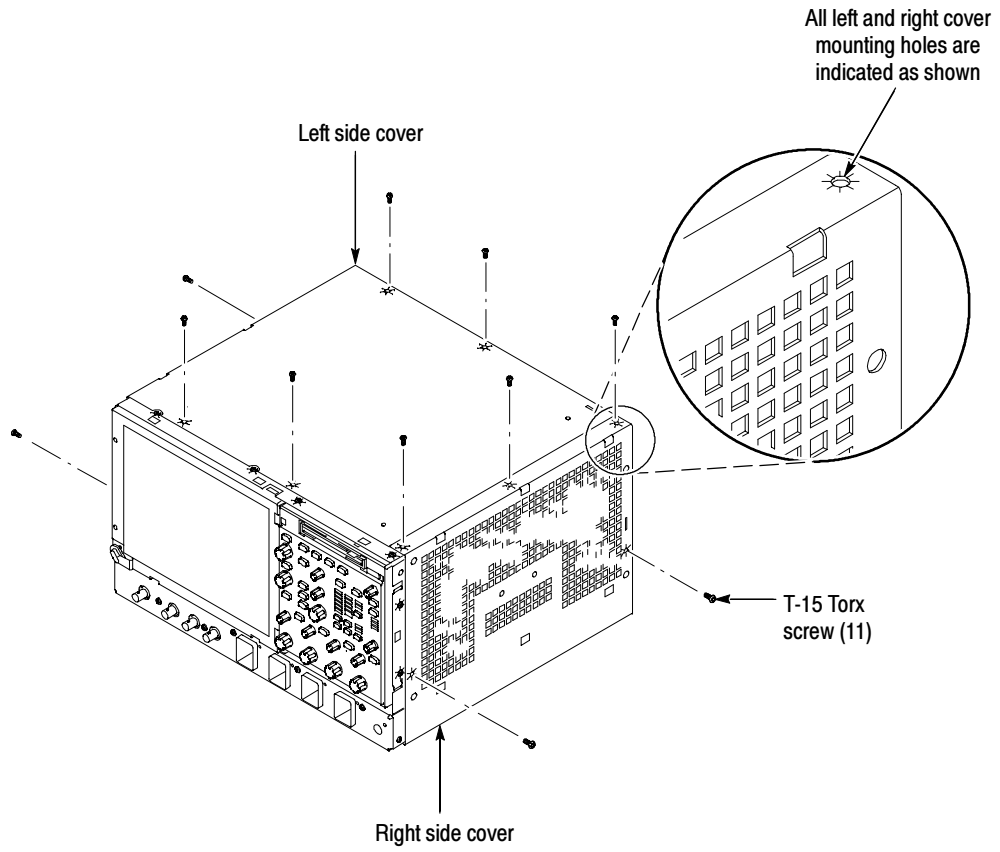

Figure 6- 4: Cover removal

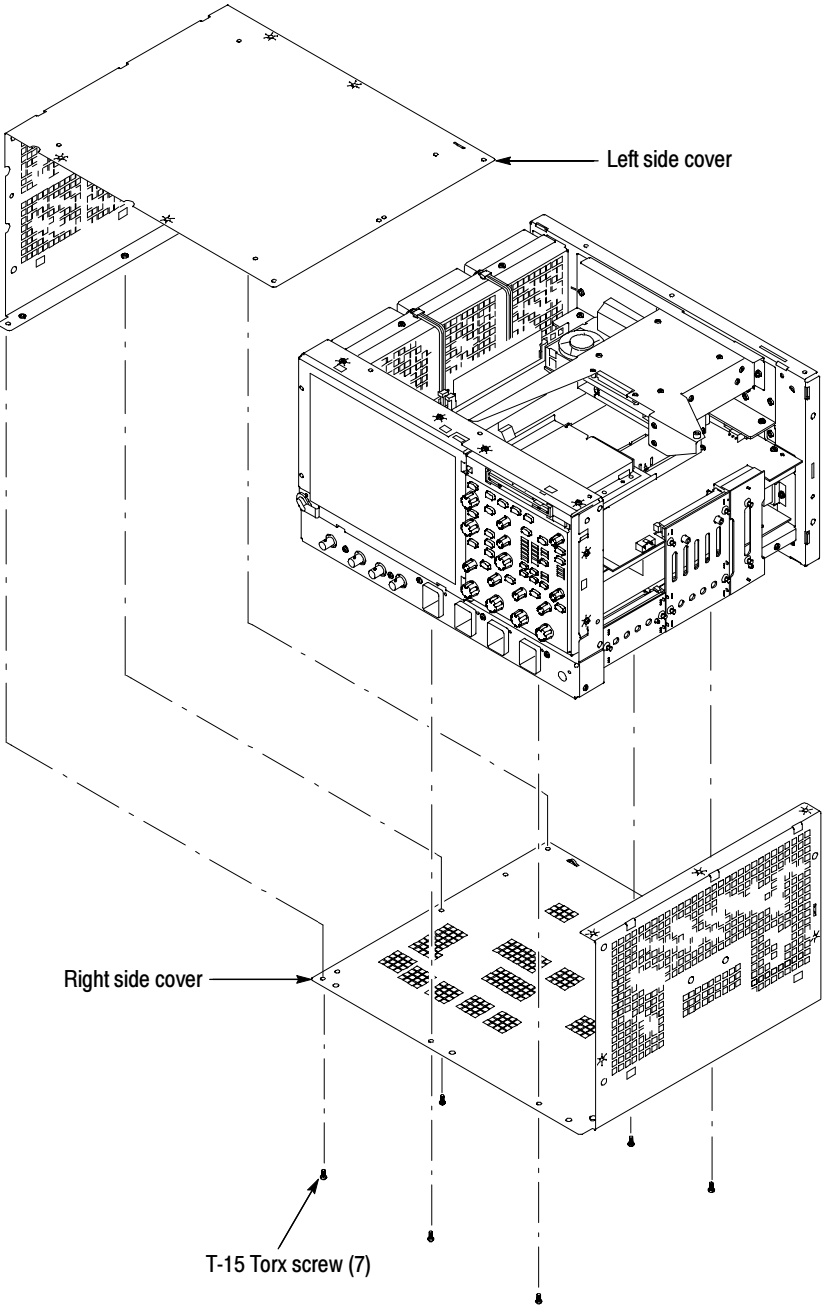

Figure 6-5: Cover removal

Line Fuses and AC power cord connector

1. *Assemble equipment and locate modules to be removed:* Locate the power switch, line fuses, and AC power cord connector in Figure 6-6, page 6-17.
2. The oscilloscope has a built-in soft power-off function that safely powers off the oscilloscope when you press the On/Standby switch.
3. Power off the rear panel power switch before servicing the line fuse or power cord.
4. *Orient the oscilloscope:* Set the oscilloscope so its bottom is down on the work surface and its rear is facing you.
5. *Remove line cord:* Find the line cord on the rear cover. Pull the line cord away to remove from the AC power connector. Reverse procedure to reinstall.
6. *Remove the line fuse:* Find the fuse caps on the rear panel. Now, remove the fuse cap by turning it counterclockwise using a flat-bladed screwdriver, and remove the line fuse. Reverse procedure to reinstall.
7. *Reinstallation:* Do in reverse steps 6 and 5 to reinstall the line cord and then the line fuse.

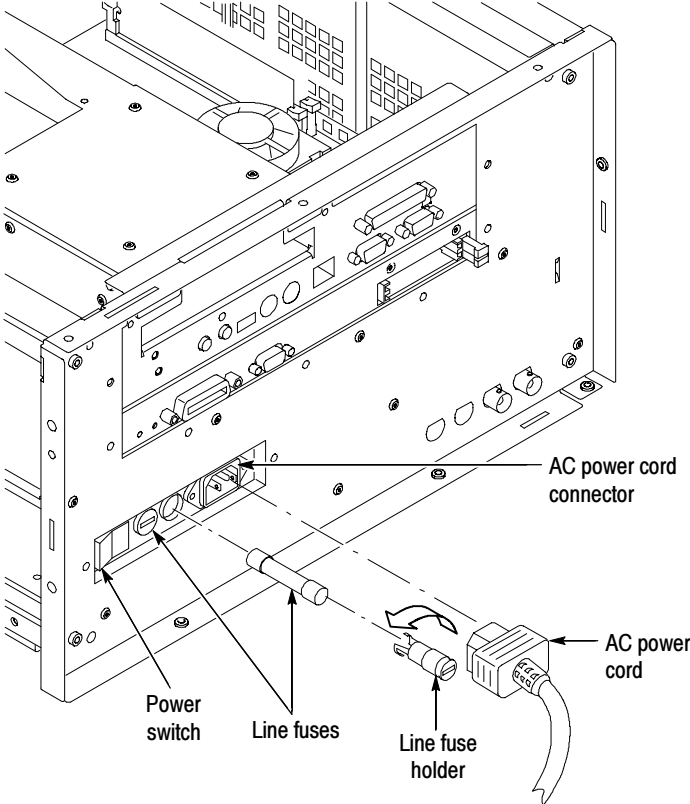

Figure 6-6: Line fuse and line cord removal

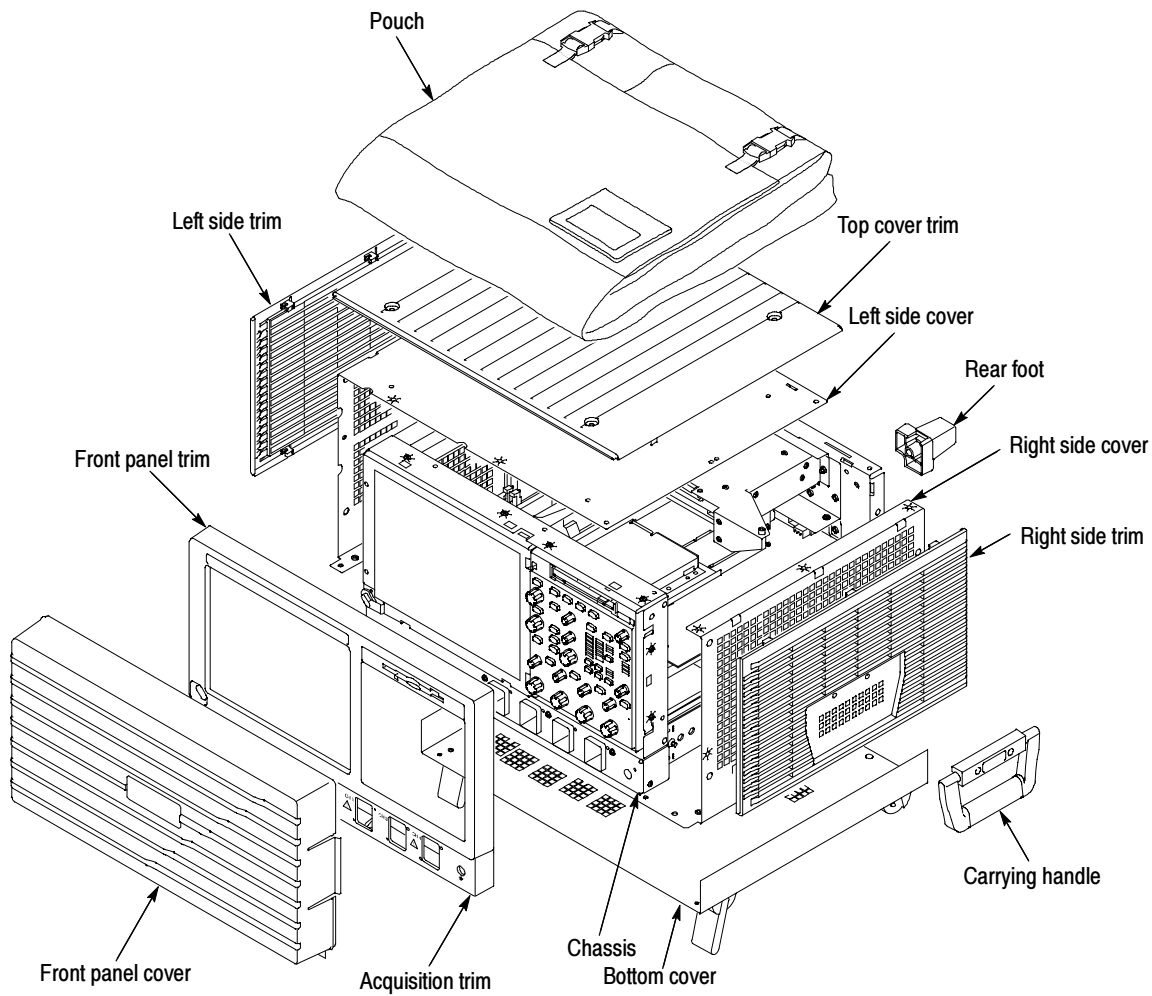

Figure 6-7: External modules

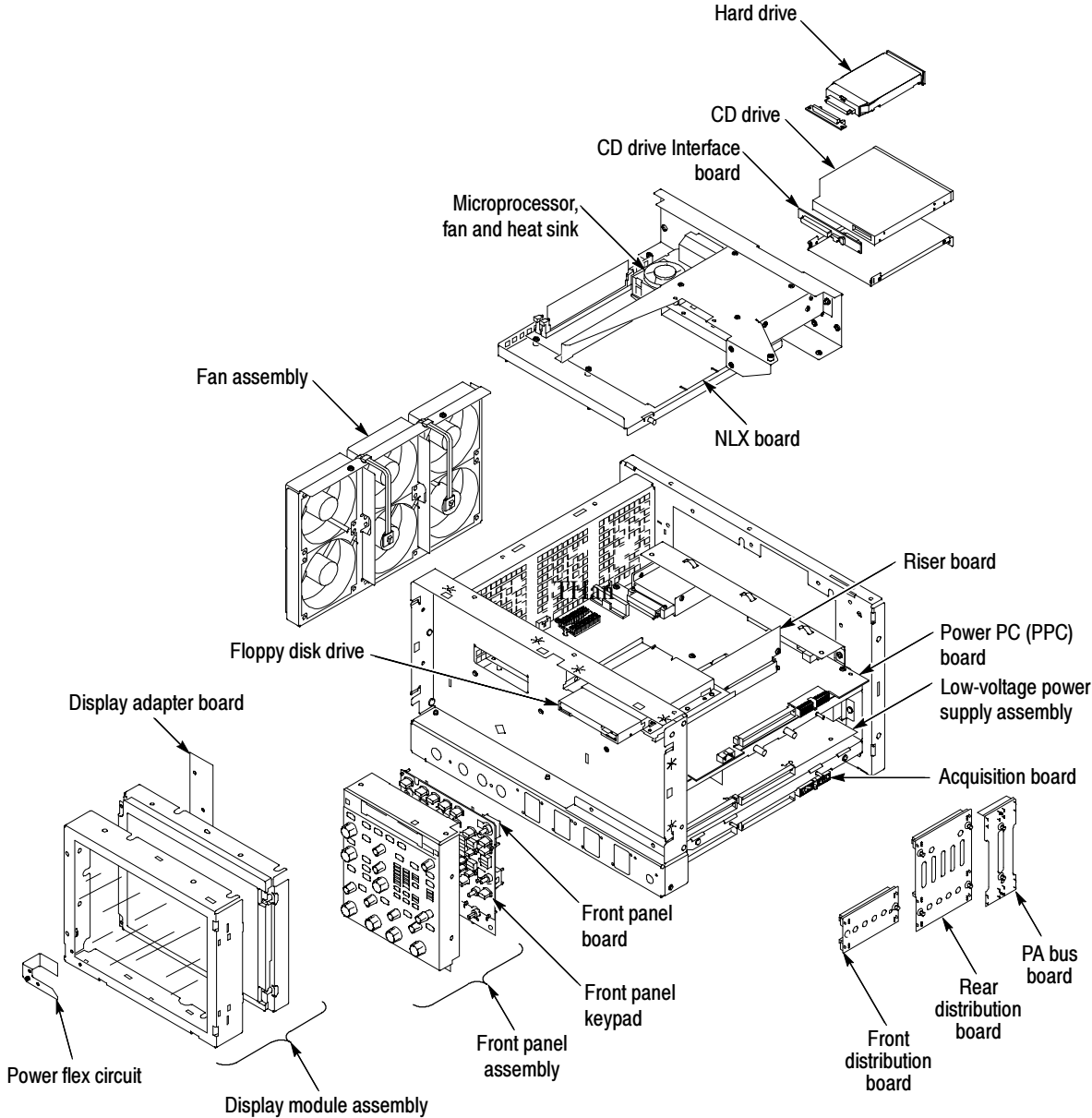

Figure 6-8: Internal modules

Procedures for Modules

You should have completed the *Procedures for External Modules* before doing many of the procedures in this collection. The procedures found here are listed in disassembly order:

- Front Panel assembly
- Front Panel Board
- Front Panel Keypad
- Display assembly
- Display Adapter Board
- On/Standby Switch Flex Circuit
- Floppy Disk Drive
- Hard Disk Drive
- CDROM-RW
- Fan assembly
- Front and Rear Power Distribution Boards (PA Bus Board)
- Low-Voltage Power Supply
- NLX Board
- Microprocessor
- Power PC Board
- Acquisition Board

Front Panel Assembly

1. *Locate module to be removed:* Locate the Front-Panel assembly in Figure 6-9, on page 6-22. Additional modules to be Removed:
 - Trim (Front panel)
2. *Remove the Front-Panel assembly:* See Figure 6-9, page 6-22.
3. *Orient the oscilloscope:* Set the oscilloscope so its bottom is down on the work surface and its front panel is facing you.
 - a. Remove the six T-15 Torxdrive screws that secure the Front-Panel assembly to the front chassis.
 - b. Grasp the top of Front-Panel assembly and pull forward to allow access to the ribbon-cable connector on the front-panel board.

- c. Use the $\frac{1}{8}$ inch flat-bladed screwdriver to carefully lift the J1 cable connector lock up to disconnect the J1 flex cable from the display module assembly. See Figure 6-10, page 6-23. Note the connector's pin 1 index mark and the black stripe on the cable for later reassembly.
 - d. Pull the Front-Panel assembly forward and remove from the oscilloscope.
4. *Reinstallation:* Do in reverse steps a through d to reinstall the front-panel assembly.

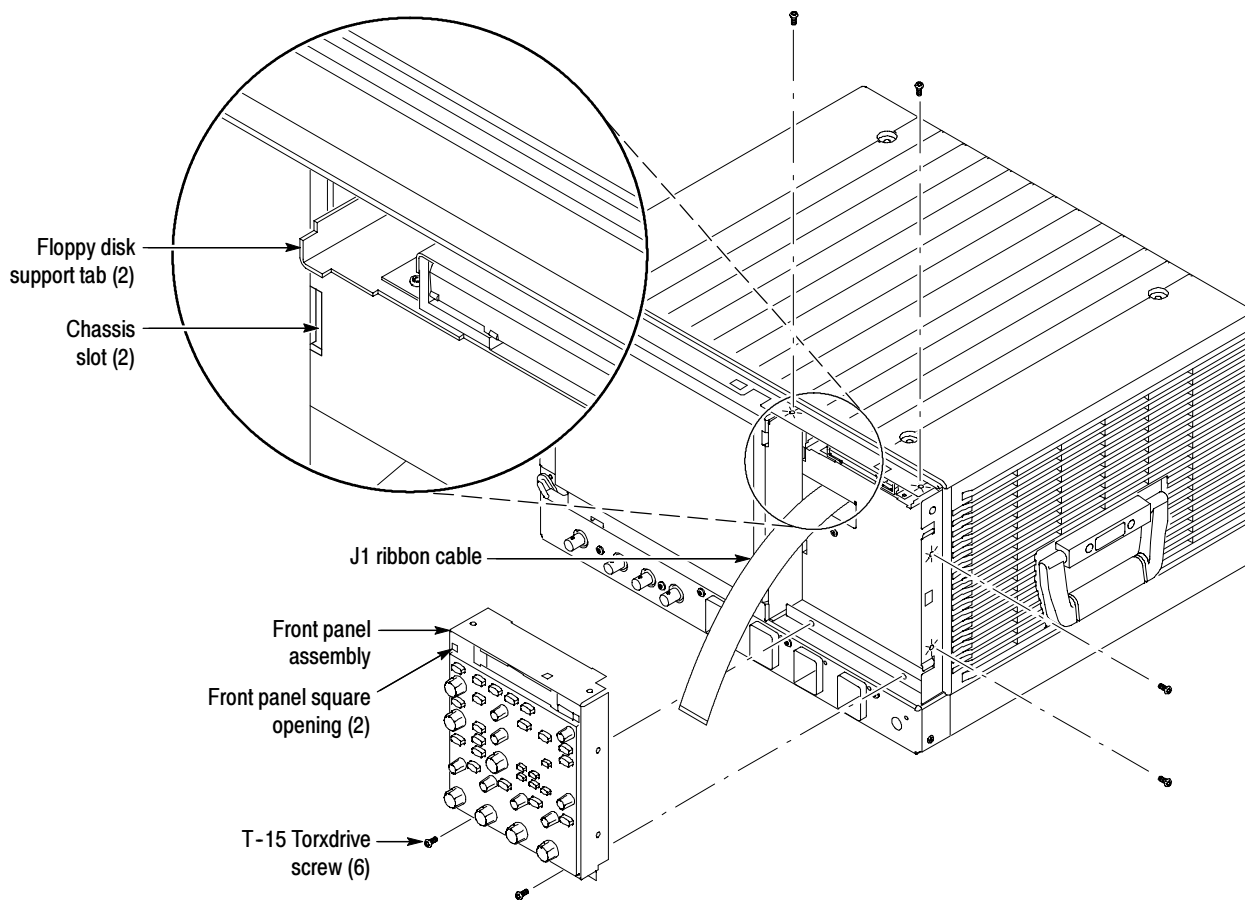

Figure 6-9: Front-panel assembly removal

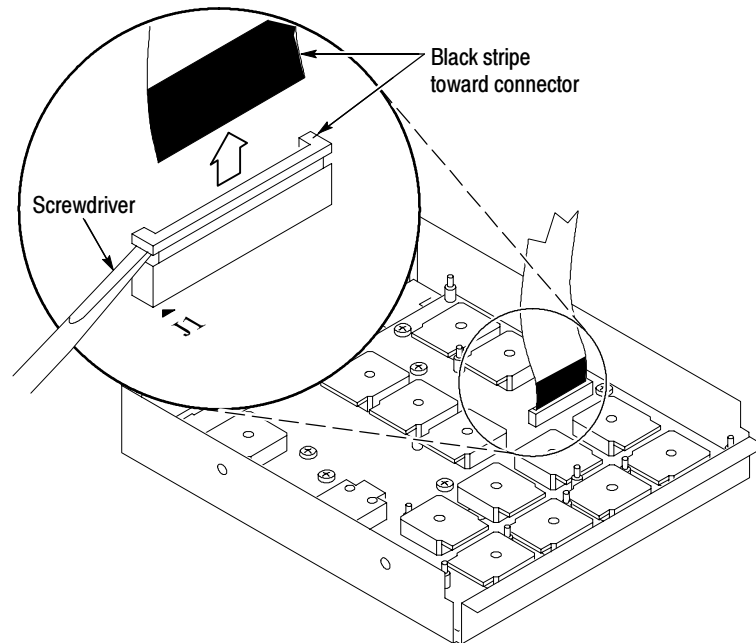

Figure 6-10: J1 flex cable connector removal

Front Panel Board

1. *Locate module to be removed:* Locate the Front Panel assembly Figure 6-9, page 6-22. Additional modules to be Removed:
 - Front Panel Knobs
 - Trim (front panel)
 - Front Panel assembly
2. *Remove the Front Panel board:* See Figure 6-11, page 6-24.
 - a. Remove the eight T-15 Torxdrive screws that secure the Front panel board to the Front panel assembly.
 - b. Pry the board up off the alignment studs. Place a flat bladed screwdriver in the pry point access holes to pry the board up from the assembly.
 - c. Remove the board from the assembly.
3. *Reinstallation:* Do in reverse steps a through c to reinstall the front panel board.

Front Panel Keypad

1. *Locate module to be removed:* Locate the Front Panel assembly in Figure 6-9, on page 6-22. Additional modules to be removed:
 - Front Panel Knobs
 - Trim (front panel)
 - Front Panel assembly
 - Front Panel Board
2. *Remove the Front Panel keypad:* See Figure 6-11.
 - a. Pull on each of the keypad support guides to separate the keypad from the Front panel board. Use a pair of tweezers or equivalent tool to pull the twelve keypad support guides.
 - b. Remove the keypad from the front panel board.

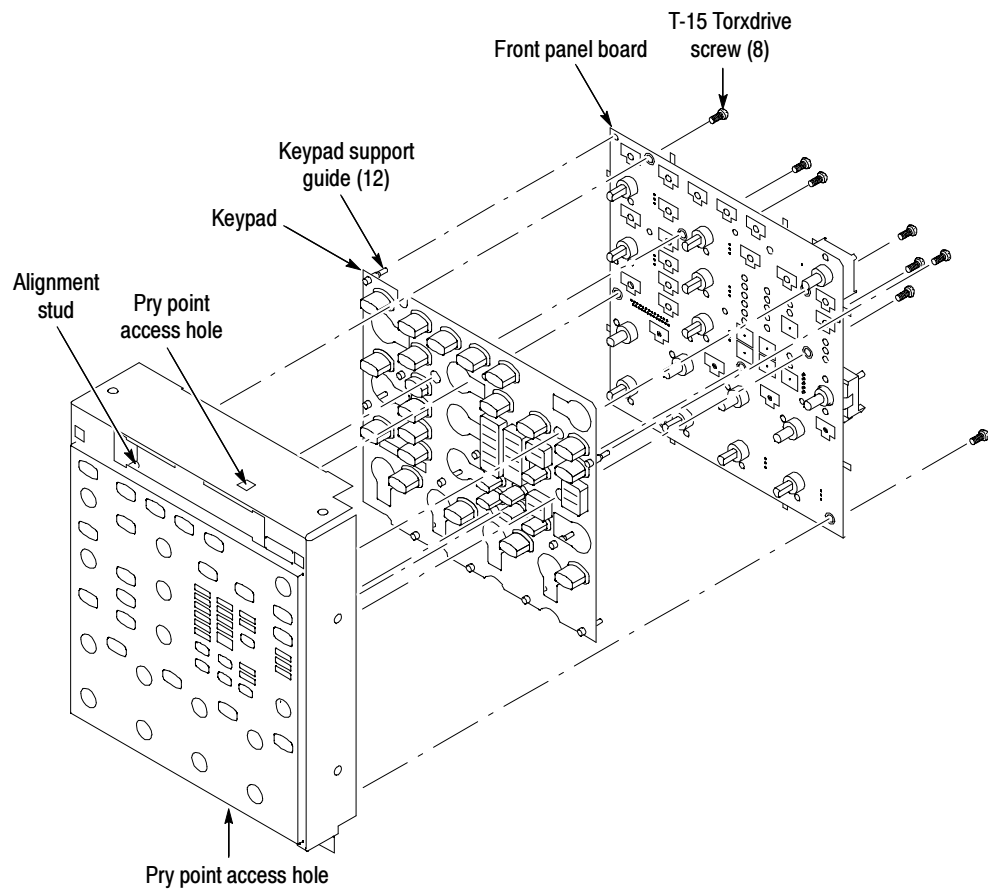

Figure 6- 11: Front panel board and keyboard removal



CAUTION. When removing or installing the keypad, make sure you do not touch the switch contacts with your fingers. The oils in your fingers will degrade or damage the switch contacts. To help prevent damage to the keypad use cotton gloves when removing or installing the keyboard pad.

3. *Reinstallation:* Do in reverse step 2 to reinstall the keypad, front panel board, and the front panel assembly. Then see the following instructions:
 - a. Make sure the keypad is aligned properly on the Front Panel board.
 - b. Make sure the ribbon cable is routed correctly when installing the Front Panel into the chassis.
 - c. Insert the two floppy disk support tabs into the front panel square openings. Both left front panel tabs must go into the chassis slots. See Figure 6-9, page 6-22.

Display Assembly

1. *Locate module to be removed:* Locate the Display assembly, Figure 6-12, page 6-26. *Additional modules to be Removed:*
 - Trim (front panel & top)
2. *Orient the oscilloscope:* Set the oscilloscope so its bottom is down on the work surface and its front panel is facing you.



CAUTION. To avoid damage to the front panel Standby/On switch assembly, do not set the Display module assembly on a work surface. Sliding the oscilloscope over the edge of the work surface could break off the On/Standby switch assembly.

3. *Remove the Display assembly:* See Figure 6-12, page 6-26.
 - a. Remove the four T-15 Torxdrive screws that secure the display assembly to the chassis.
 - b. Grasp the display assembly at the finger reliefs located at the top-right and bottom-left corners of the display assembly and pull forward far enough to allow access to the flex cable connector.
 - c. Disconnect the J5 flex cable from the display assembly. Remove the display module assembly from the oscilloscope. See Figure 6-12, page 6-26.

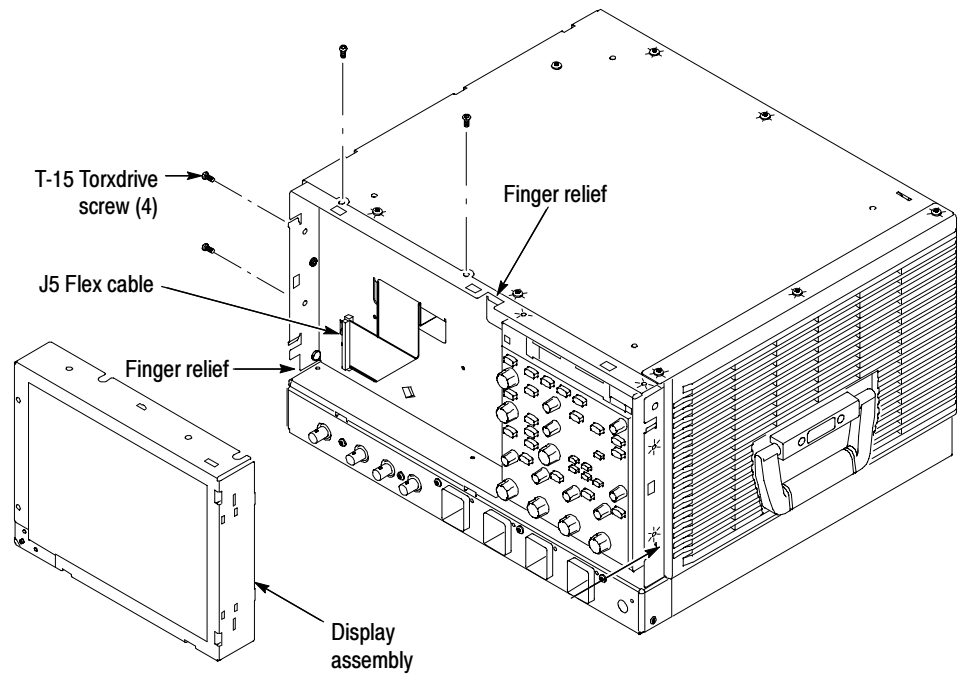

Figure 6- 12: Display removal

4. Remove the Touch panel from the Display assembly: See figures 6-13 and 6-15, on pages 6-27 and 6-28.



CAUTION. To prevent degradation of the display sharpness, this procedure must be performed in a dust free environment. The service technician should wear cotton gloves to prevent finger oils from contaminating any surfaces of the display glass.

- a. Disconnect cables J1 and J7 from the Display Adapter circuit board.
- b. Separate the assembly by carefully prying the Touch panel (outer) assembly from the Display (inner) assembly. Insert a flat-bladed screwdriver in the access notches to push out on the Touch panel assembly.

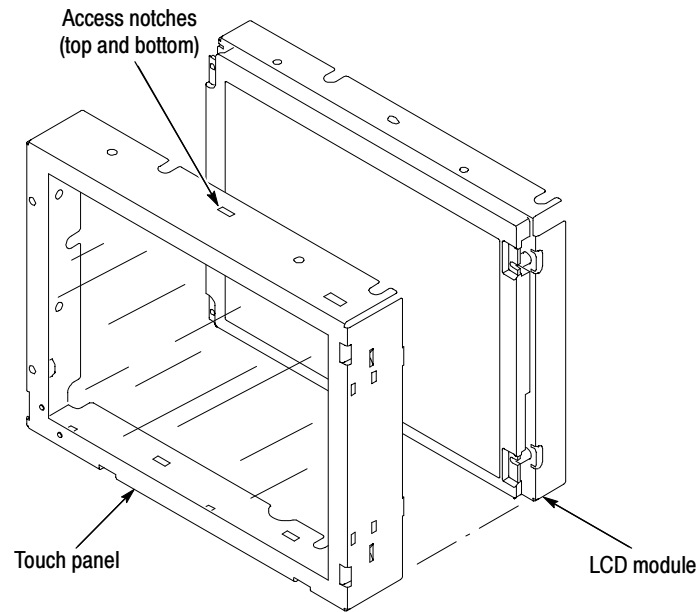

Figure 6-13: Touch panel and LCD assembly removal

5. *Reinstallation:* Do in reverse steps 1 through 5 to reinstall the Display assembly.

Display Adapter Board

1. *Locate module to be removed:* Locate the display adapter board in the locator diagram *Internal Modules*, Figure 6-8, on page 6-19. Additional modules to be Removed:
 - Trim (front panel & top)
 - Display assembly
2. *Remove the Display Adapter Board:* See Figure 6-15, pages 6-28.
 - a. Disconnect cables J1, J6, J5, and J7 from the Display Adapter board.
 - b. Disconnect the display cable to J4 on the Display Adapter circuit board. Slide the cable clamp (provided in this kit) away from the cable and from under the Display Adapter circuit board. See Figure 6-14.
 - c. Remove the three T-15 Torxdrive screws that secure the Display Adapter circuit board to the Display assembly. Remove the Display Adapter from the assembly.
3. *Reinstallation:* Do in reverse steps a and c to reinstall the board.

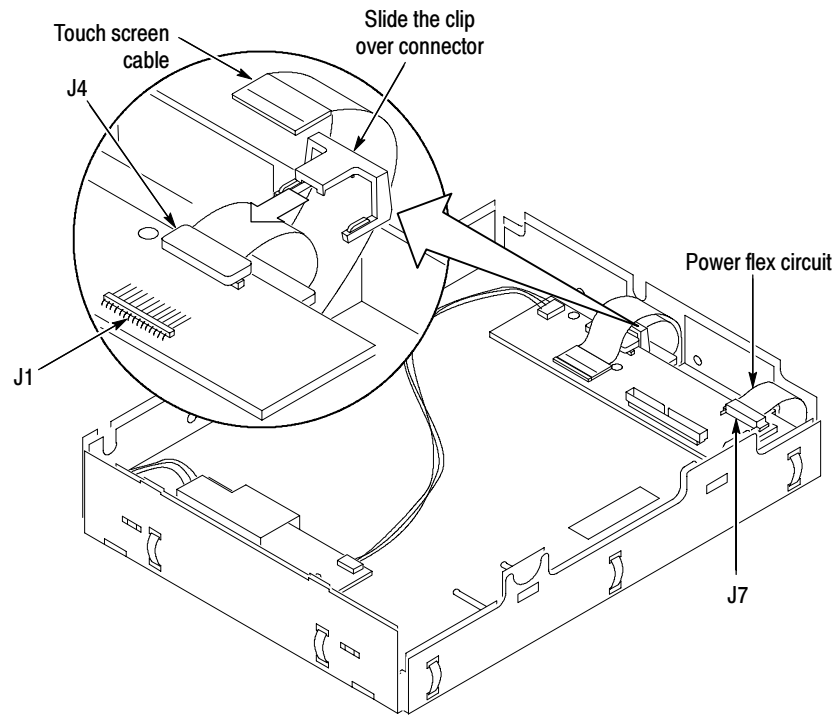

Figure 6-14: J4 cable clamp detail

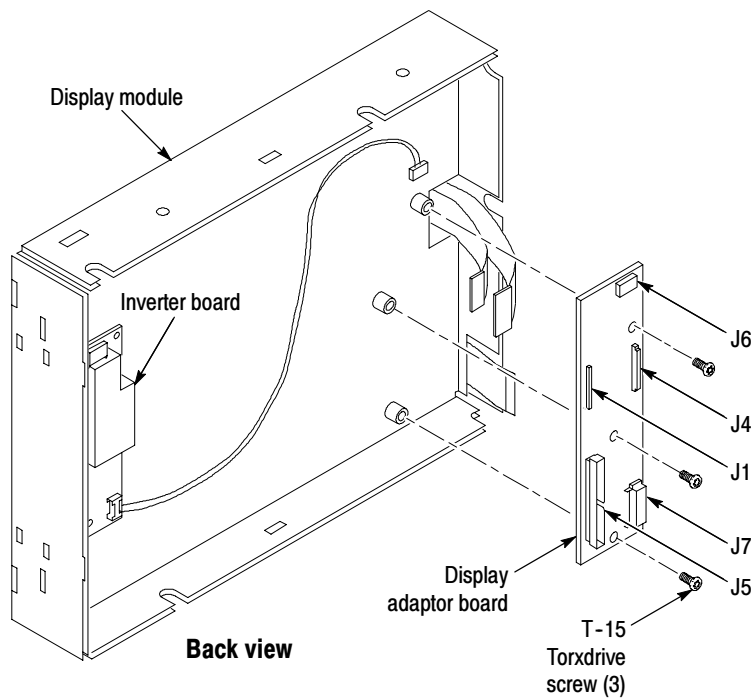

Figure 6-15: Display adaptor board removal

**On/Standby Switch Power
Flex Circuit Removal**

1. *Locate module to be removed:* Locate the On/Standby Switch power flex circuit in the locator diagram *Internal Modules*, Figure 6-8, page 6-19. Additional modules to be removed:
 - Trim (front panel)
 - Display assembly
2. *Orient the assembly:* Set the display adapter so its back is down on the work surface and its front is facing you.
3. *Remove the On/Standby Switch power flex circuit:* See Figure 6-16, on page 6-30.
 - a. Peel the On/Standby switch power flex circuit away from the front of the display assembly.
 - b. Disconnect the flex circuit from J7 on the Display Adapter circuit board.
 - c. Grasp the flex circuit and pull it out of the Display assembly.
4. *Reinstallation:* Do following procedure to reinstall the On/Standby Switch.
 - a. Remove the protective backing on the power flex circuit.
 - b. Slide the connector end of the power flex circuit through the slot in the Display assembly. Make sure the flex circuit connector aligns with J7 on the Display Adapter circuit board.
 - c. Align the holes in the power flex circuit to the two index posts on the front side of the Display assembly.
 - d. Firmly press the flex circuit to the Display assembly chassis surface.

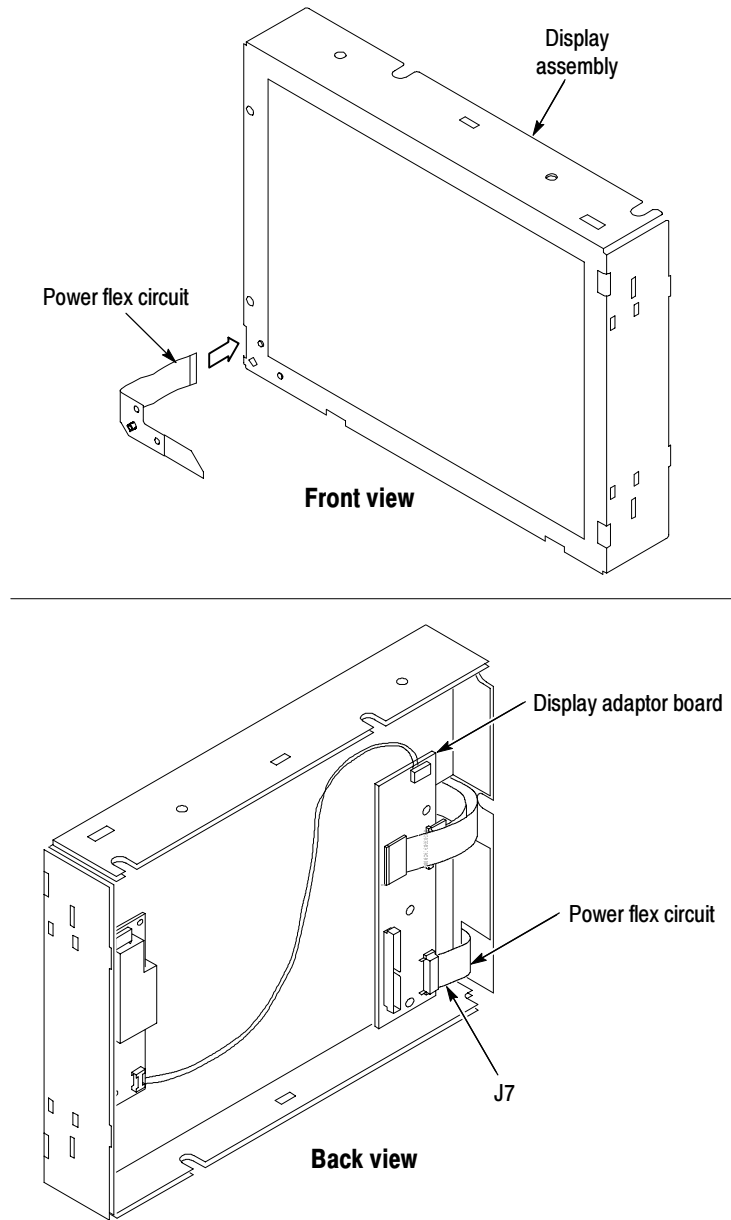
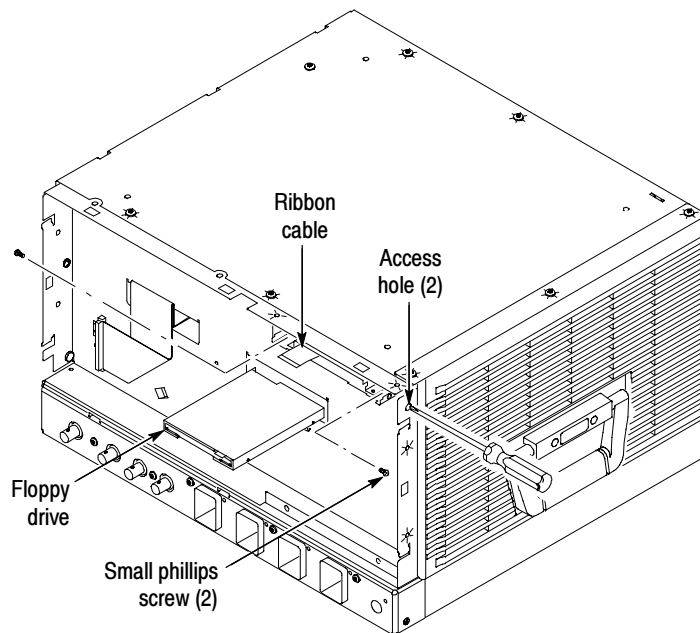

Figure 6- 16: Power flex circuit removal

Floppy Disk Drive

1. *Locate modules to be removed:* Locate the Floppy Disk Drive in the locator diagram *Internal Modules*, Figure 6-8, page 6-19. Additional modules to be Removed:
 - Trim (front panel and top)
 - Front Panel assembly
 - Display assembly
2. *Remove the floppy disk drive:* Use Figure 6-17 as a guide. A #0 Phillips screwdriver is required for this procedure.
3. *Orient the oscilloscope:* Set the oscilloscope so its bottom is down on the work surface and its front panel is facing you.
 - a. Remove the two small phillips screws that secure the floppy disk drive assembly to the bracket. Use the access hole located on the outer chassis to remove one of the small phillips screws.
 - b. Slide the floppy drive out toward the front of the oscilloscope far enough to allow you to disconnect the ribbon cable connector.
 - c. Remove the floppy drive from the oscilloscope.
4. *Reinstallation:* Do in reverse steps a through c to reinstall the floppy disk drive.

**Figure 6-17: Floppy disk drive removal**

Hard Disk Drive

1. *Locate module to be removed:* Locate the Hard Disk Drive in the locator diagram *Internal Modules*, Figure 6-8, page 6-19.



CAUTION. *Do not remove the replaceable hard disk drive when the oscilloscope is powered on.*

The replaceable hard disk drive may be permanently damaged if it is removed while the oscilloscope is powered on.

Always power off the oscilloscope before removing the replaceable hard disk drive.

2. *Orient the oscilloscope:* Set the oscilloscope so its bottom is down on the work surface and its rear panel is facing you.
3. *Remove the hard disk drive:* See Figure 6-18, on page 6-33.
 - a. Verify that the oscilloscope is powered down.
 - b. Push the hard disk drive cover in and the hard drive will disconnect from the latch.
 - c. Grasp the hard disk drive assembly and slide it out of the oscilloscope.
4. *Reinstallation:* Do in reverse step 3 to reinstall the hard disk drive assembly. The hard disk drive will push in to lock and push in again to unlock.

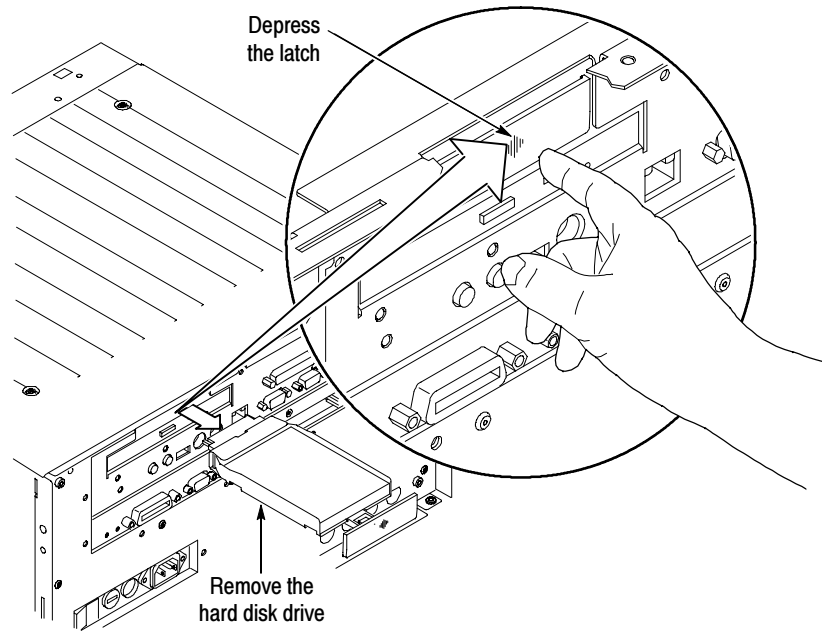

Figure 6-18: Hard disk drive removal

5. *Remove the hard disk drive from the cartridge:* See Figure 6-19, on page 6-33.
 - a. Remove the four #0 Phillips screws that fasten the hard disk drive to the cartridge.
 - b. Carefully remove the hard disk drive from the cartridge, and remove the cable assembly from the connector on the hard disk drive.

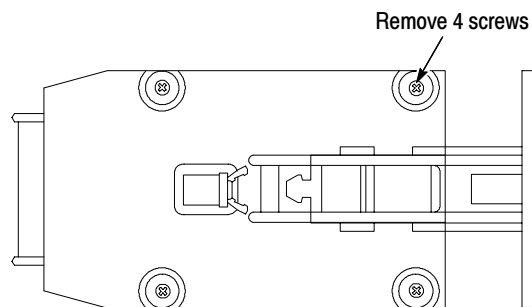

Figure 6-19: Removing the hard disk drive from the cartridge

CDROM-RW

1. *Locate module to be removed:* Locate the CDROM-RW in the locator diagram *Internal Modules*, Figure 6-8, on page 6-19. Additional modules to be Removed:
 - Trim (all)
 - Bottom cover
 - Left and Right covers
2. *Remove the CDROM-RW assembly:* See Figure 6-20, on page 6-35.
3. *Orient the oscilloscope:* Set the oscilloscope so its bottom is down on the work surface and its rear panel is facing you.
 - a. Remove the two T-15 Torxdrive screws that secure the CDROM-RW assembly to the rear chassis.
 - b. Disconnect the CDROM-RW ribbon cable J230 from the Riser board.
 - c. Slide the CDROM-RW assembly (with the ribbon cable attached) toward the rear of the chassis and remove it from the oscilloscope.
4. *Remove the CDROM-RW bracket and Rom interface board:* See Figure 6-20, on page 6-35.
 - a. Remove the four #0 Phillips screws that secure the bracket to the CDROM-RW. Remove the CDROM-RW from the bracket.
 - b. Remove the Interface board from the CDROM-RW by pulling the Interface board straight back until they separate.
5. *Reinstallation:* Do in reverse steps 3 and 4 to reinstall the CDROM-RW assembly.

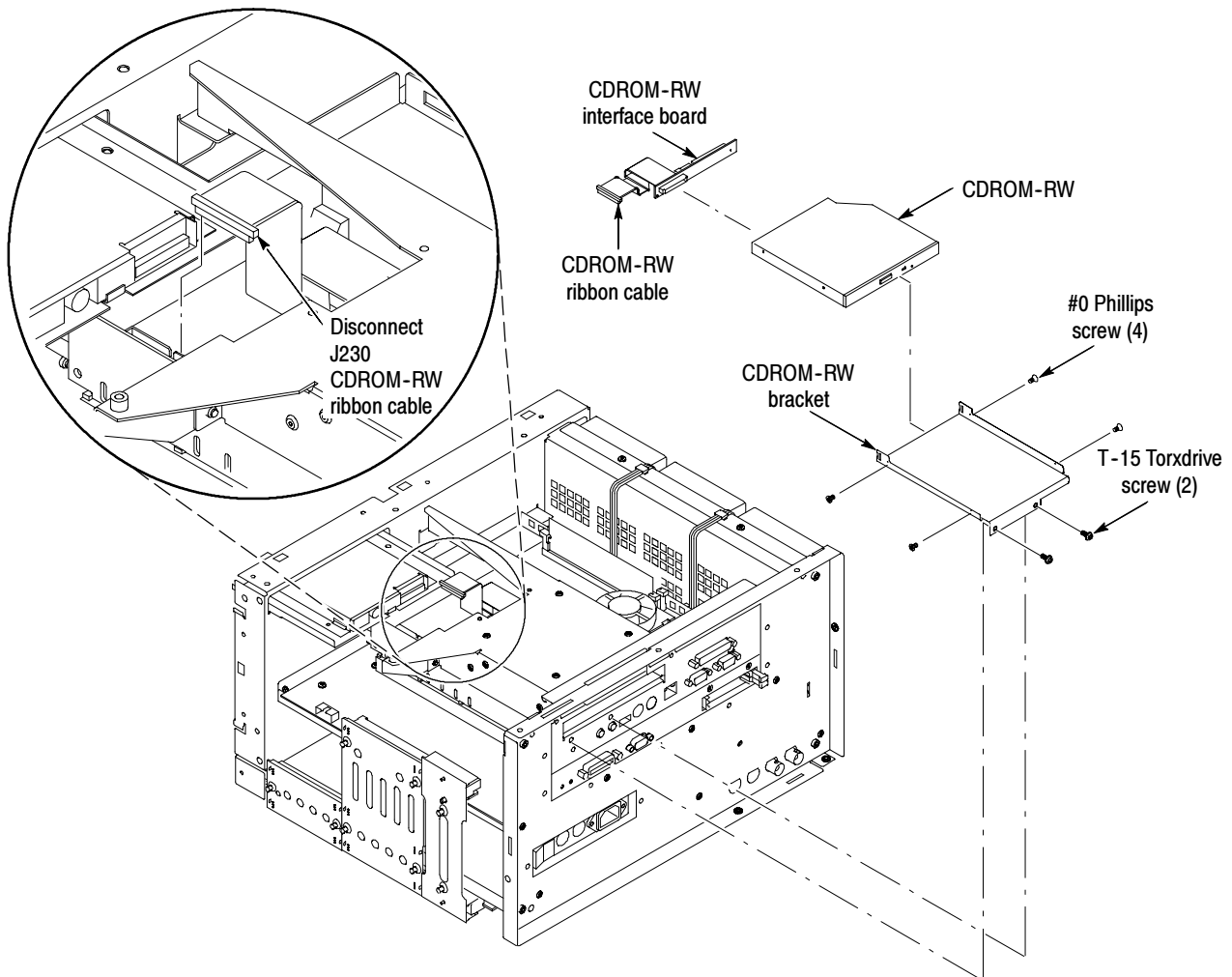

Figure 6-20: CDROM-RW and bracket removal

Fan Assembly Removal

1. *Locate module to be removed:* Locate the Fan assembly in the locator diagram *Internal Modules*, Figure 6-8, on page 6-19. Additional modules to be Removed:
 - Trim (all)
 - Bottom cover
 - Left and Right covers
2. *Orient the oscilloscope:* Set the oscilloscope so its bottom is down on the work surface and its left side is facing you.
3. *Remove the fan:* See Figure 6-21, on page 6-36.

- a. *Disconnect the fan from the processor/display board:* Disconnect the two fan power cables J130 and J170 located on the processor board.
 - b. Remove the two T-15 Torxdrive screws securing the fan assembly to the top main chassis.
 - c. Lift the fan assembly up and out from the chassis.
4. *Reinstallation:* Do in reverse steps a through c to reinstall the fan assembly.



CAUTION. Take care when handling the fan assembly, the fan blades are brittle and can be easily damaged.

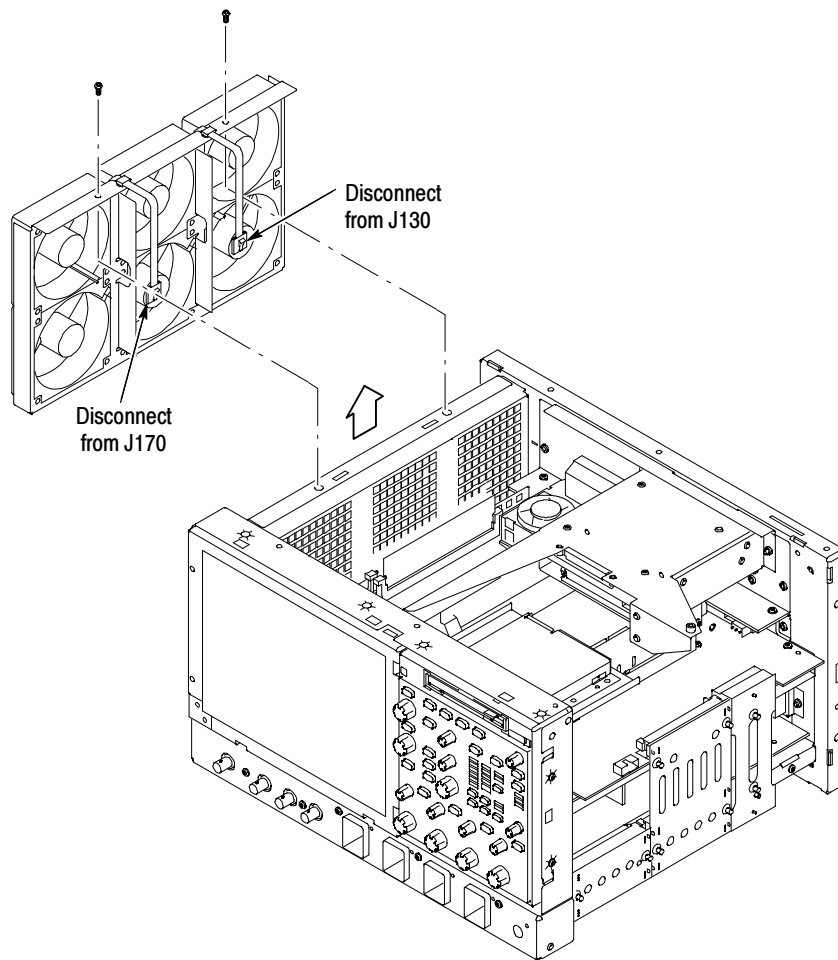

Figure 6-21: Fan assembly removal

**Front and Rear Power
Distribution Circuit
Boards**

1. *Assemble equipment and locate modules to be removed:* Find the modules to be removed in the locator diagram *Internal Modules*, Figure 6-8, on page 6-19. Additional modules to be Removed:
 - Trim (all)
 - Bottom cover
 - Left and Right covers
2. *Orient the oscilloscope:* Set the oscilloscope so its left side is down on the work surface and its right side is facing you.
3. *Remove the Front Power Distribution board:* See Figure 6-22, on page 6-38.
 - a. Grasp the Front Power Distribution board and pull it out from the oscilloscope to disconnect it from the following connectors: J2 Power supply board and J102 Acquisition board.
 - b. *Remove the Rear Power Distribution board:* Grasp the Rear Power Distribution board and pull it out from the oscilloscope to disconnect it from the following connectors: J201 Processor board, J1 Power supply board, and J102 Acquisition board.
 - c. *Remove the PA Bus Interconnect board:* Grasp the PA Bus Interconnect board and pull it out from the oscilloscope to disconnect it from the following connectors: J930 Processor board and J100 Acquisition board.
4. *Reinstallation:* Do in reverse step 3 to reinstall the front and rear power distribution and the PA bus interconnect boards.

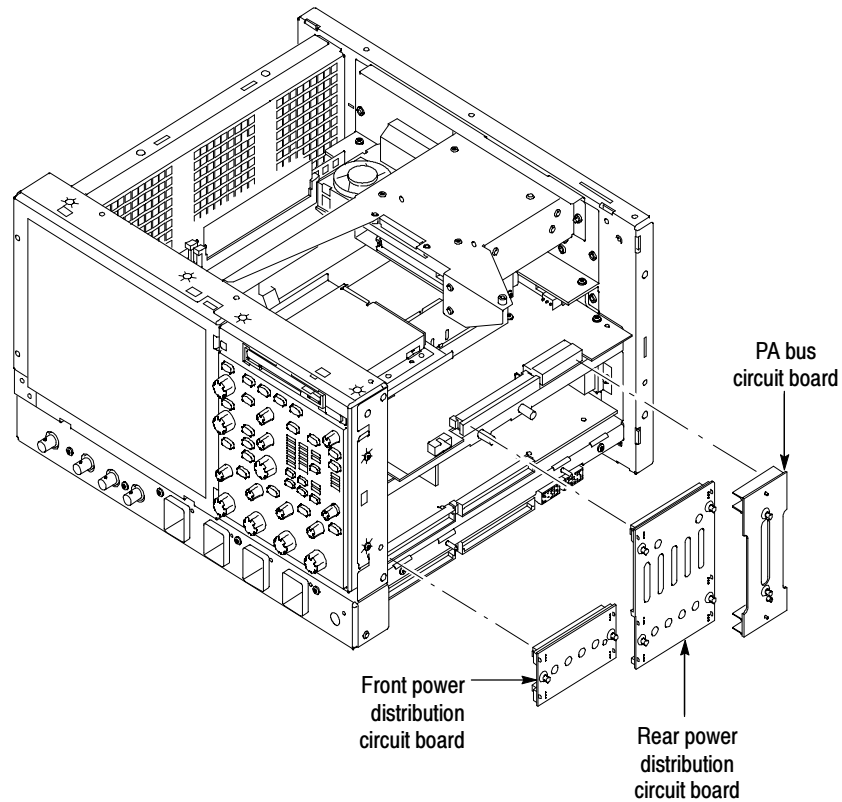

Figure 6-22: Front and rear power distribution and PA bus boards removal

Low-Voltage Power Supply

1. *Assemble equipment and locate modules to be removed:* Locate the modules to be removed in the locator diagram *Internal Modules*, Figure 6-8, on page 6-19. Additional modules to be Removed:
 - Trim (all)
 - Bottom cover
 - Left and Right covers
 - Front and Rear Distribution Boards and the PA bus interconnect board
2. *Orient the oscilloscope:* Set the oscilloscope so its bottom is down on the work surface and its right-side is facing you.
3. *Remove the low-voltage power supply:* See Figure 6-23, on page 6-39.
 - a. Remove the two T-15 Torxdrive screws securing the low-voltage power supply to the right-side chassis support.

- b. Remove the three T-15 Torxdrive screws securing the low-voltage power supply to rear chassis.
 - c. Grasp the low-voltage power supply and carefully slide the assembly out of the oscilloscope.
4. *Reinstallation:* Do in reverse steps a through c to reinstall the low-voltage power supply.

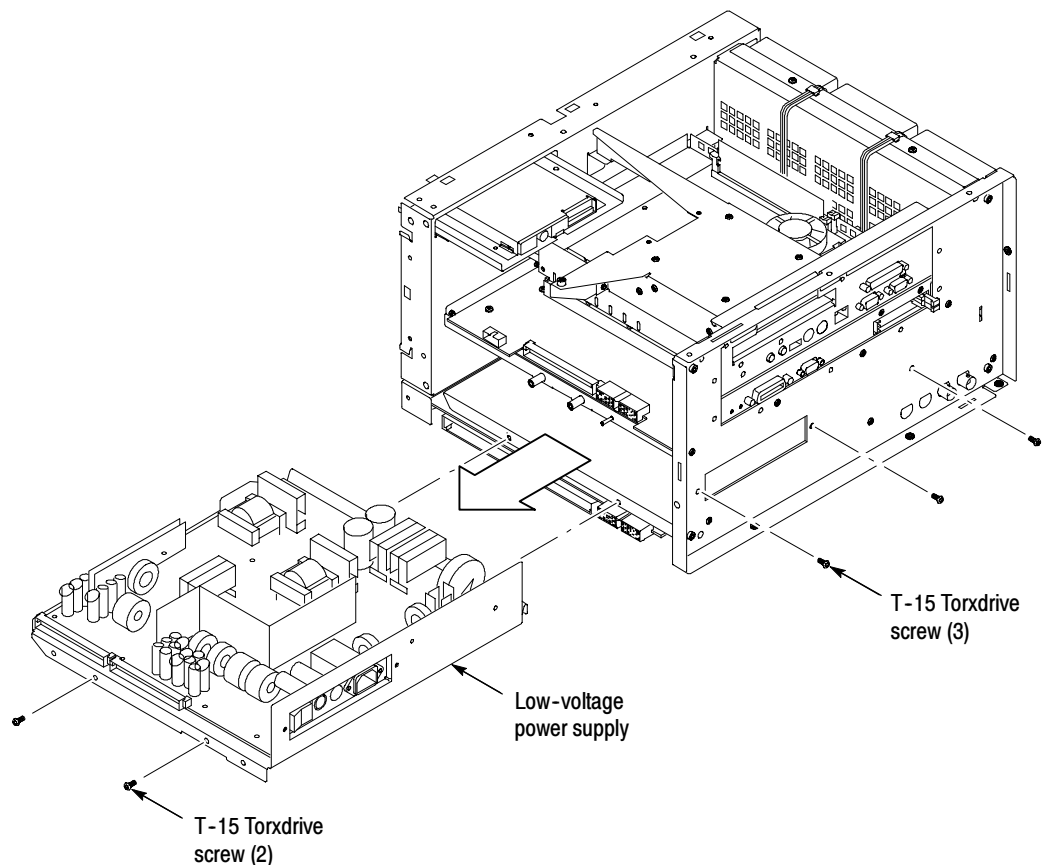

Figure 6-23: Low-voltage power supply removal

NLX Board

1. *Locate module to be removed:* Locate the NLX Board in the locator diagram *Internal Modules*, Figure 6-8, on page 6-19. Additional modules to be removed:
 - Trim (all)
 - Bottom cover
 - Left and Right covers
2. *Remove the NLX Board assembly:* See Figure 6-24, page 6-41.
3. *Orient the oscilloscope:* Set the oscilloscope so its bottom is down on the work surface and its top panel is facing you.
 - a. Remove the two T-15 Torxdrive screws that secure the floppy disk drive assembly into the front chassis.
 - b. Slide the floppy drive assembly, with cable attached, out toward the rear of the oscilloscope. Place floppy drive assembly on top of the hard/CDROM-RW bracket.
 - c. Remove the five T-15 Torxdrive screws that secure NLX board assembly to the chassis.
 - d. Remove the five T-15 Torxdrive screws that secure NLX board assembly to the rear chassis.
 - e. Grasp the front edge of the NLX board assembly and pull up on the assembly to disconnect the Riser Adapter from the Processor board edge connector.
 - f. Remove the NLX board assembly from the oscilloscope.

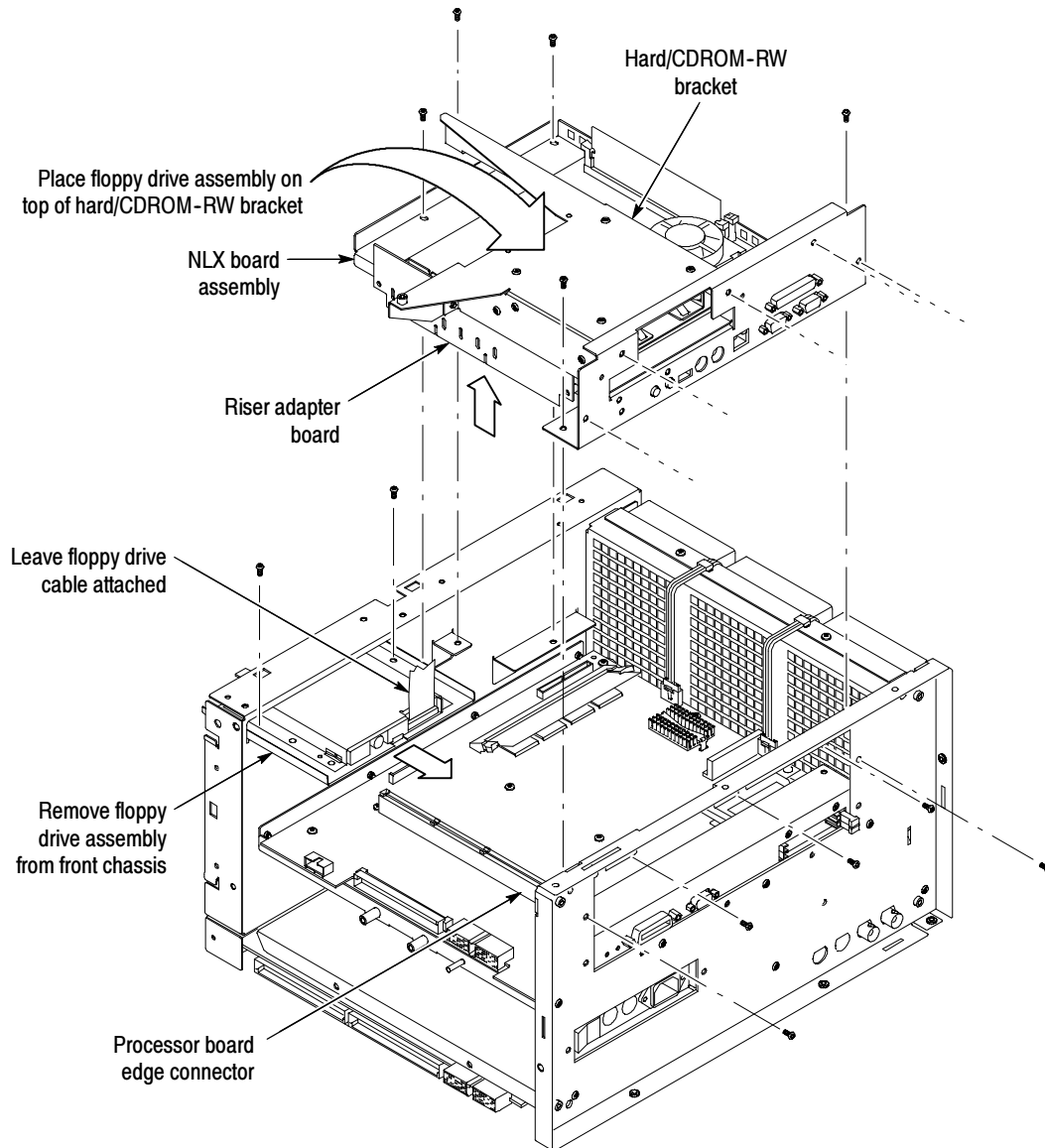

Figure 6-24: NLX assembly removal

4. *Remove the Riser Adapter and NLX Boards:* See Figure 6-25, on page 6-43.
 - a. Remove the two T-15 Torxdrive screws that secure Riser Adapter board to the NLX support bracket.
 - b. Disconnect the ribbon cable connectors from the floppy drive, hard drive and CDROM-RW.
 - c. Remove the floppy drive assembly from the NLX board assembly.

- d.** Grasp the Riser board and pull it straight out to disconnect J510 edge card connector from the NLX board. Remove the Riser Adapter board from the NLX board assembly.
 - e.** Remove the four T-15 Torxdrive screws that secure NLX board to the NLX support bracket.
 - f.** Remove the six $\frac{3}{16}$ nut posts that secure the three connectors to the rear of the support bracket. Then remove the NLX board from the support bracket.
 - g.** Remove the NLX board from the support bracket.
- 5.** *Reinstallation:* Do in reverse steps 3 and 4 to reinstall the NLX board.

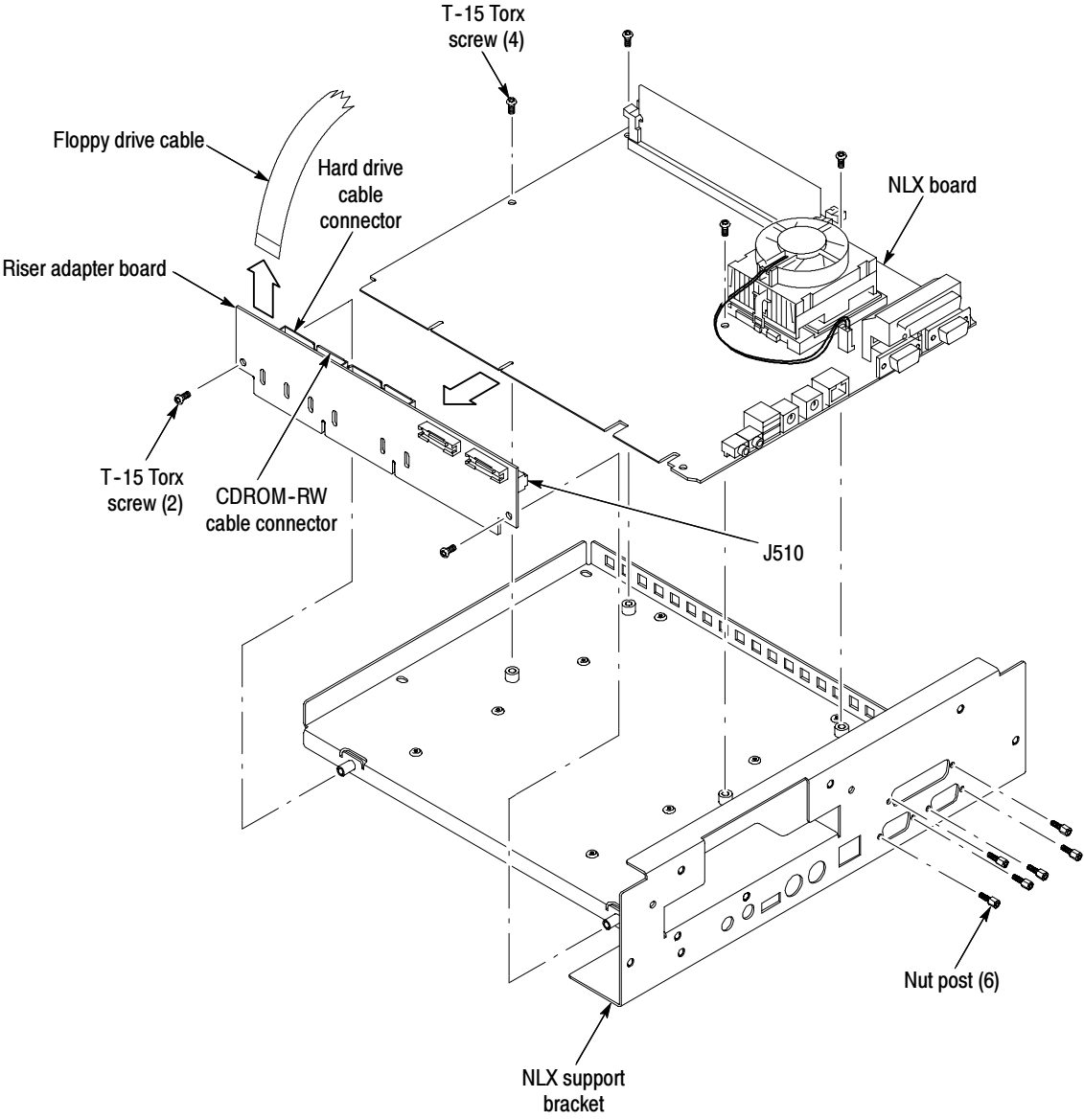

Figure 6-25: Riser adapter and NLX board removal

Microprocessor

1. *Locate module to be removed:* Locate the microprocessor board in the locator diagram *Internal Modules*, Figure 6-8, on page 6-19. Additional modules to be removed:
 - Trim
 - Bottom cover
 - Left and Right covers



CAUTION. *The microprocessor is susceptible to static-discharge damage. Service this component only in a static-free environment. Observe standard handling precautions for static-sensitive devices while servicing the oscilloscope. Always wear a grounded wrist and foot straps while servicing the microprocessor, NLX or processor boards.*

2. *Remove the microprocessor:* See Figure 6-26, on page 6-45.
 - a. Disconnect the fan power cable J14 from P14 on the NLX board.
 - b. Push down and pull out on the holding bracket located nearest to the outer edge of the circuit board.
 - c. Pull out and unlatch the remaining bracket.
 - d. Lift the microprocessor socket locking lever upward. Remove the microprocessor.
3. *Reinstallation:* Reinstall the microprocessor to the NLX board as follows:
 - a. Install the microprocessor in the socket.
 - b. Lower the socket locking lever.
 - c. Make sure the fan/heatsink assembly is positioned with the fan cable toward the outer edge of the circuit board.
 - d. Place the fan/heatsink assembly on the microprocessor to allow you to latch the bracket to the tab that is nearest to the center of the circuit board.
 - e. Set the remaining edge of the fan/heatsink down on the microprocessor and fasten the remaining bracket to the assembly.
 - f. Connect the fan power cable J14 to P14 on the NLX board.

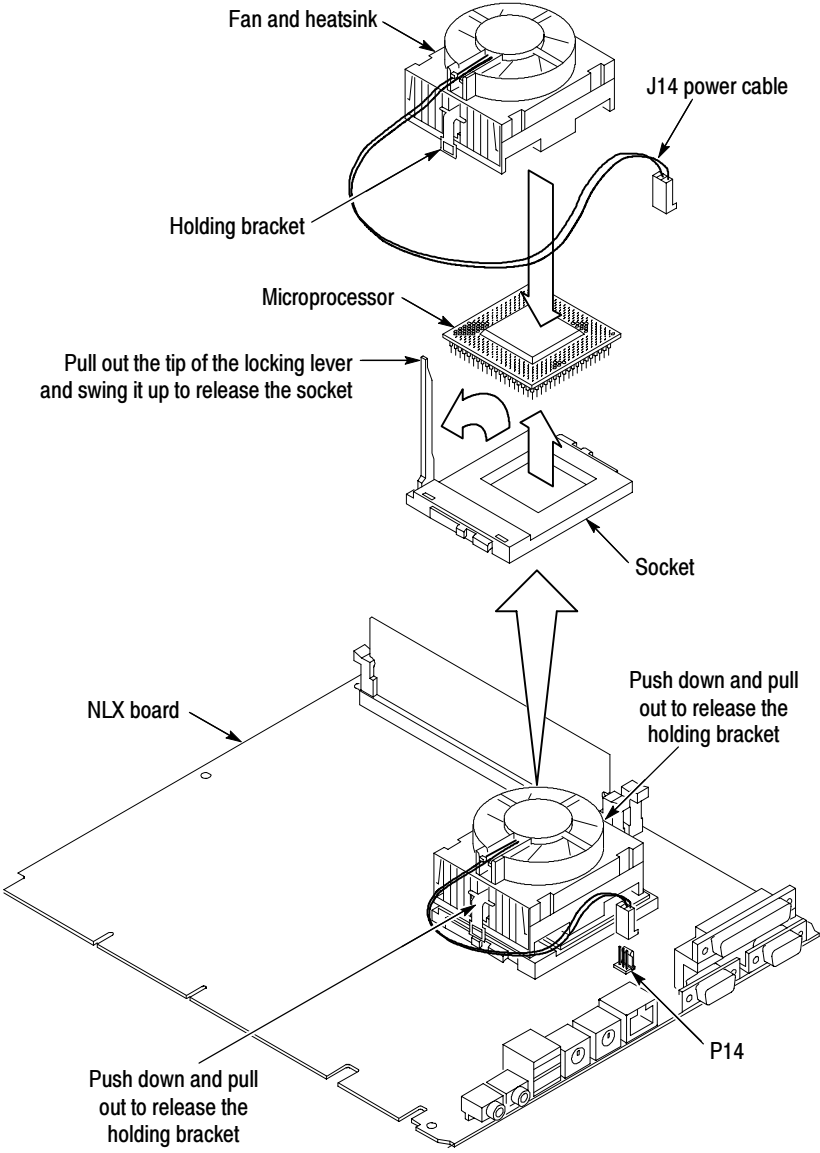

Figure 6-26: Microprocessor removal

PPC Processor Board

1. *Locate module to be removed:* Locate the PPC (Power PC) processor board assembly in the locator diagram *Internal Modules*, Figure 6-8, on page 6-19. Additional modules to be removed:
 - Trim (all)
 - Bottom cover
 - Left and Right covers
 - Hard Disk and CDROM-RW
 - Floppy Disk Drive
 - NLX Board
 - Front, Rear Power Distribution and PA Bus Boards
2. *Orient the oscilloscope:* Set the oscilloscope so its bottom is down on the work surface and its top panel is facing you.
3. *Remove the PC processor board assembly:* See Figure 6-27, on page 6-47.
 - a. Disconnect the J190 and J690 ribbon cables and cables J130 and J170 from the PPC processor board.
 - b. Remove the nine T-15 Torxdrive screws securing the PPC processor to the chassis support.
 - c. Remove the five T-15 Torxdrive screws securing the PPC processor board assembly to the rear chassis.
 - d. Remove the board and bracket.
4. *Remove the PPC processor board bracket:* See Figure 6-27, on page 6-47.
 - a. Remove the two $\frac{3}{16}$ nut posts that secure the RS-232 connector to the rear of the support bracket.
 - b. Remove the two $\frac{5}{16}$ nut posts that secure the sub-D connector to the rear of the support bracket.
 - c. Remove the two phillips screws that secure the PCMCIA (Personal card, memory card interface adapter) to the PC processor board. Remove the PCMCIA and bracket from the PPC processor board.
5. *Reinstallation:* Do in reverse steps 3 and 4 to reinstall the PPC processor board assembly.

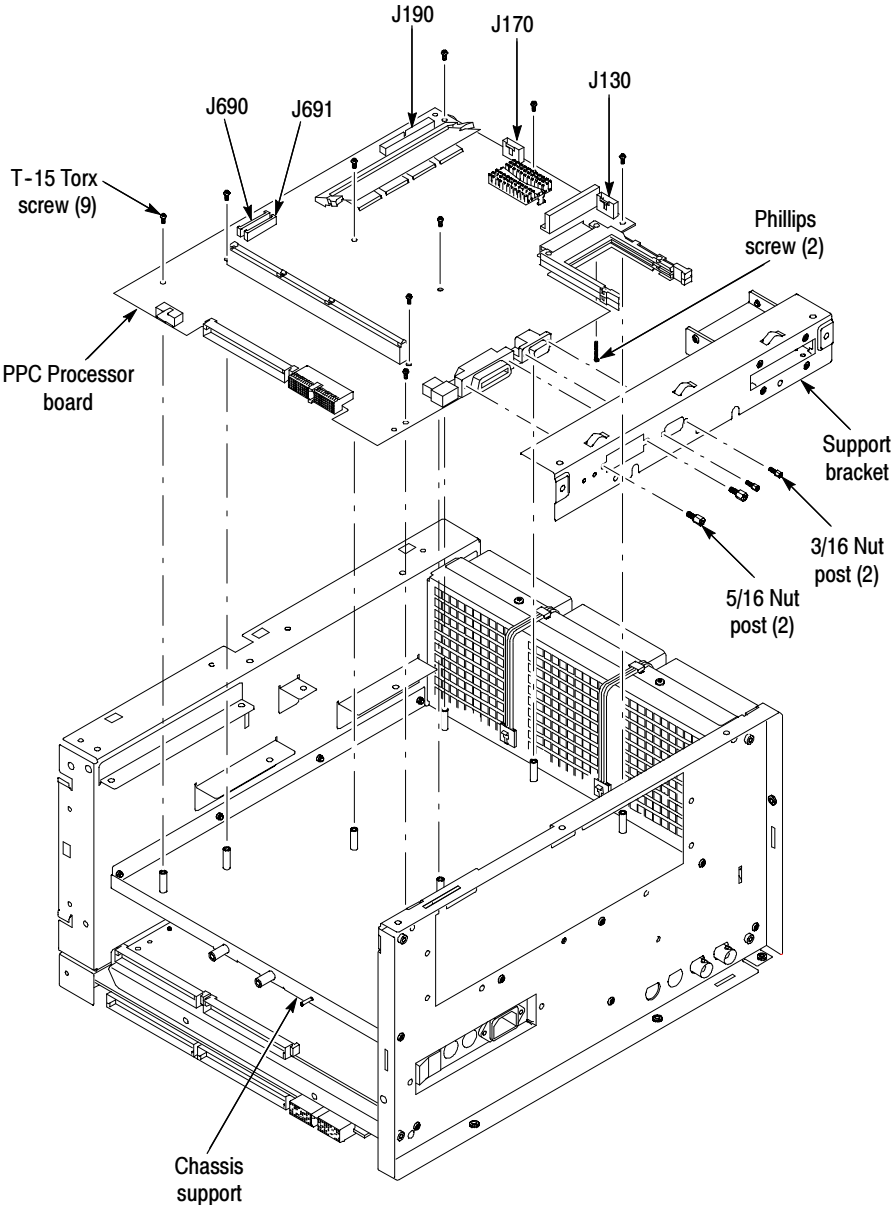

Figure 6-27: PPC Processor board removal

Acquisition Board

1. *Locate module to be removed:* Locate the Acquisition board in the locator diagram, Figure 6-8, on page 6-19. Additional modules to be removed:
 - Trim
 - Bottom cover
 - Left and Right covers
 - Front and Rear Power Distribution Boards (PA Bus board)
2. *Orient the oscilloscope:* Set the oscilloscope so its top is down on the work surface and its bottom is facing you.
3. *Remove the Acquisition board:* See Figure 6-28, page 6-50.
 - a. Disconnect J2000 and J2001, EXT REF and REF OUT respectively coaxial cables from the rear panel BNC connectors. Slide the cables through and out of the relay bracket.
 - b. Remove the 13 Torxdrive T-15 screws securing the Acquisition assembly to the front chassis.
 - c. Remove the six Torxdrive T-15 screws securing the Acquisition assembly to the chassis.
 - d. Slide the Acquisition board toward the rear of the oscilloscope. Then lift the board out of the oscilloscope.

NOTE. *If you are replacing the acquisition board assembly, do not remove the remaining parts, they are part of the replaceable assembly.*

4. *Remove the Front Panel Combination assembly:* See Figure 6-29, page 6-51.
 - a. Remove the TekConnect ribbon cable by grasping the sides of the connector and pulling up.
 - b. Remove the four cables connected to the BNCs. Take note of which BNC each cable is connected to for later reassembly.
 - c. Remove the $\frac{7}{16}$ nut from the inside front of the 4 TekConnect buckets.
 - d. Remove the three T-15 Torxdrive screws securing the Acquisition board to the Front Panel Combination assembly.
 - e. Carefully separate the Acquisition board from the combination assembly chassis at the front corners of the Acquisition board.

5. *Remove the TekConnect circuit board:* See Figure 6-30, page 6-52. Remove the five T-15 Torxdrive screws securing the TekConnect board to the combination assembly.
6. *Remove a TekConnect bucket:* See Figure 6-30, page 6-52. Remove the three T-15 Torxdrive screws securing the TekConnect bucket to the Front Panel Combination assembly.

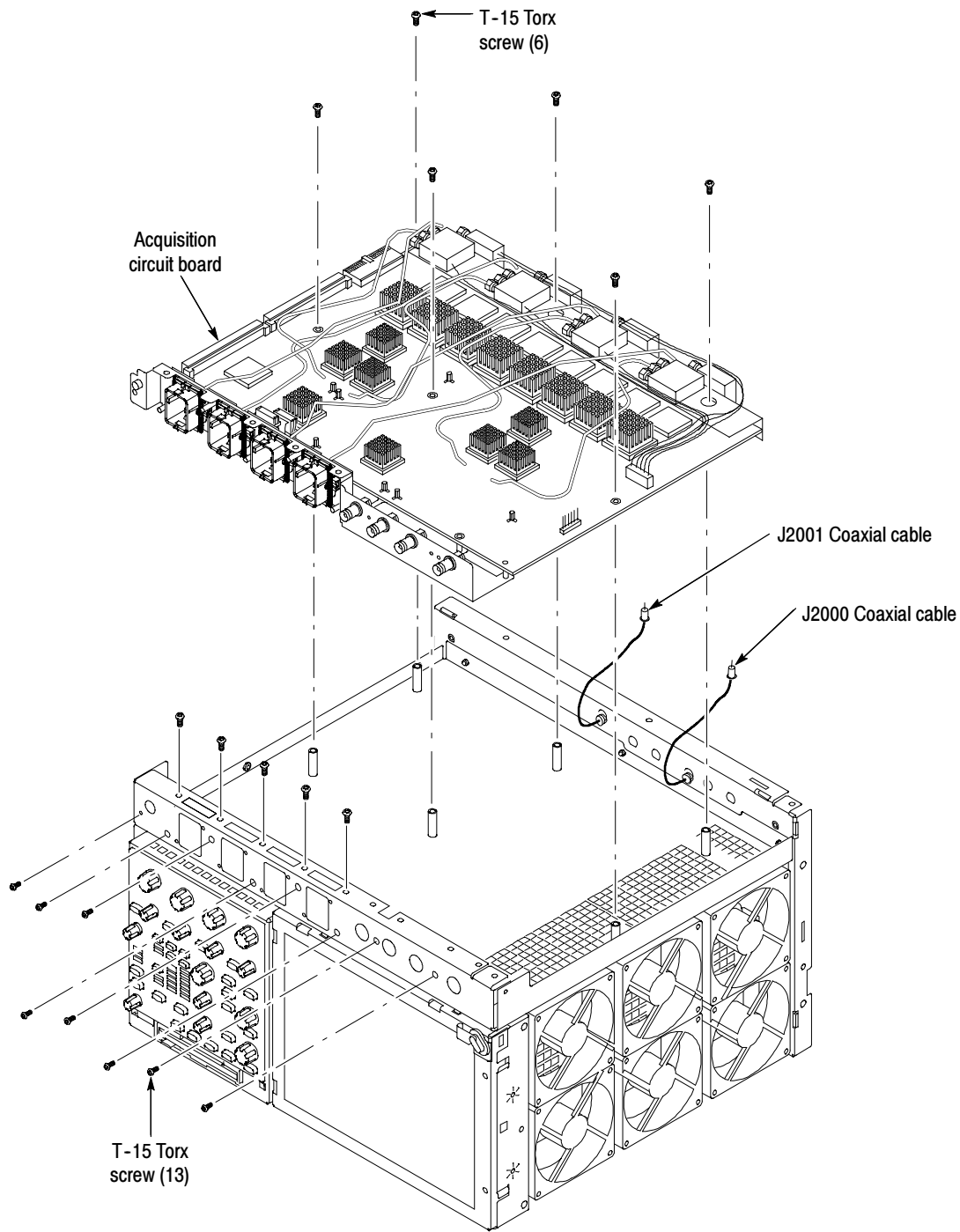

Figure 6-28: Acquisition circuit board removal

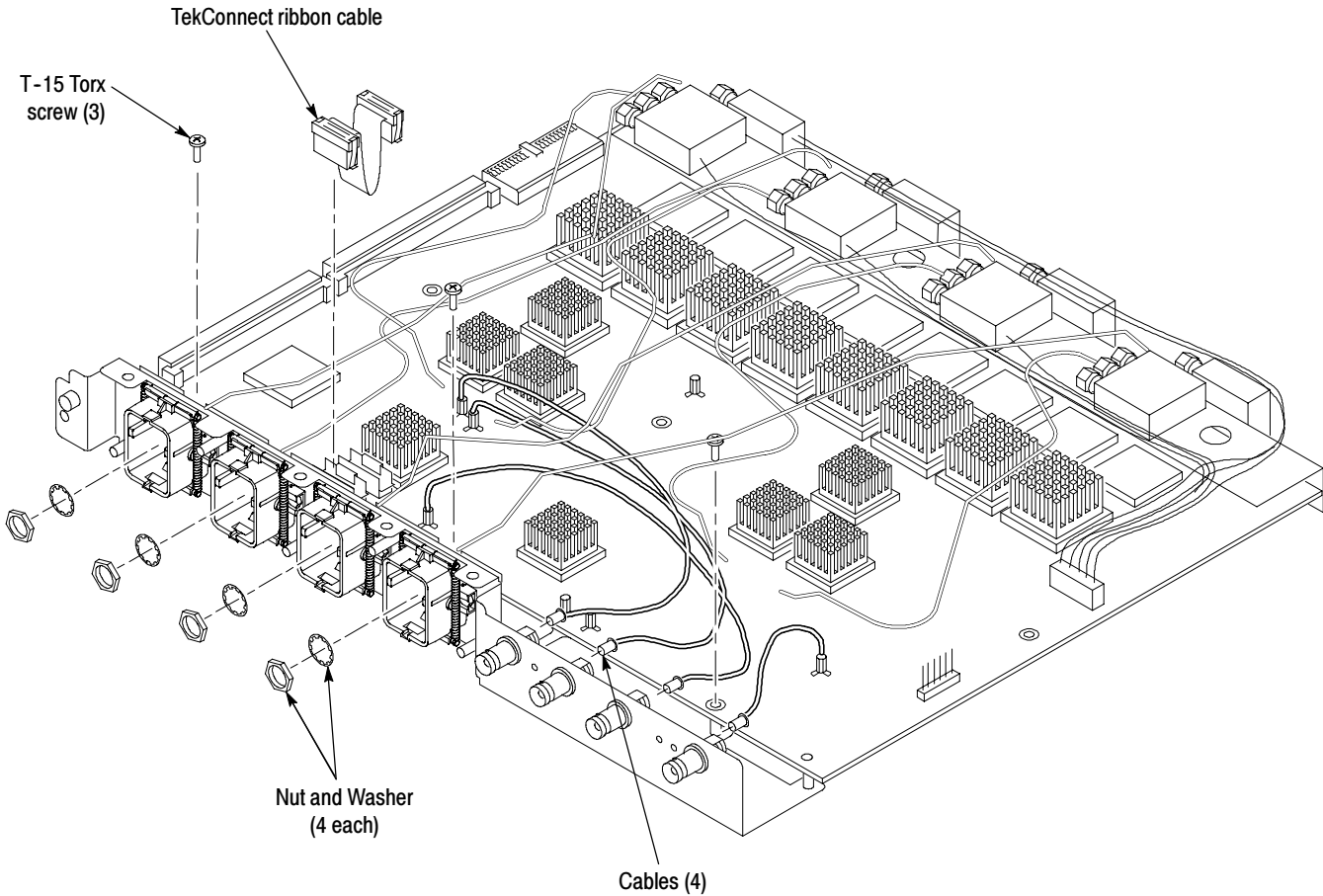

Figure 6-29: Front panel combination assembly removal

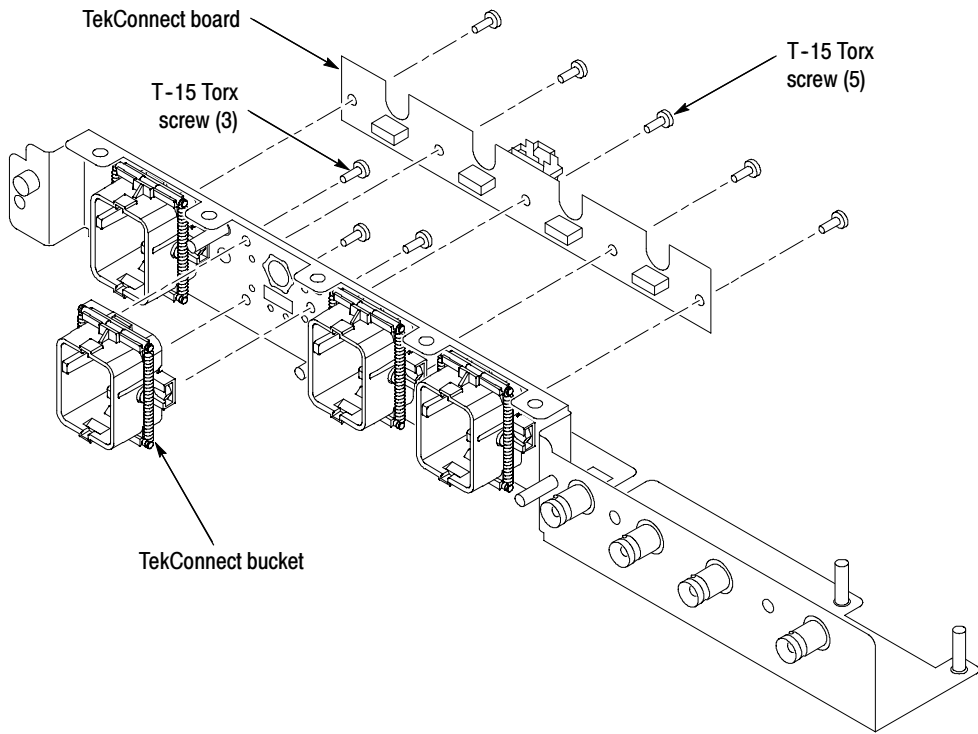

Figure 6-30: TekConnect board and TekConnect bucket removal

Troubleshooting



WARNING. Before performing this or any other procedure in this manual, read the General Safety Summary and Service Safety Summary found at the beginning of this manual.

To prevent possible injury to service personnel or damage to electrical components, please read Preventing ESD on page 6-1.

This section contains information and procedures designed to help you isolate faults to a module.

This section assumes that service personnel have the prerequisite skills required to work on this oscilloscope, including PC troubleshooting and Windows 98 skills. Details of PC and Windows 98 operation and service are not in this manual.

For assistance, contact your local Tektronix Service Center.

Service Level

This subsection contains information and procedures designed to help you isolate faulty modules in the oscilloscope. If a module needs to be replaced, follow the *Removal and Installation Procedures* located in this section.

Check for Common Problems

Use Table 6-4 to quickly isolate possible failures. The table lists problems and possible causes. The list is not exhaustive, but it may help you eliminate a problem that is quick to fix, such as a blown fuse or loose cable.

Table 6-4: Failure symptoms and possible causes

Symptom	Possible cause(s)
Oscilloscope will not power on	<ul style="list-style-type: none">■ Power cord not plugged in■ Failed fuse■ Mains power switch is in off position■ Faulty power supply
Front panel light comes on (oscilloscope powers on), but one or more fans will not operate	<ul style="list-style-type: none">■ Faulty fan cable■ Defective fan assembly■ Faulty power supply

Table 6-4: Failure symptoms and possible causes (Cont.)

Symptom	Possible cause(s)
PPC appears “dead”; power light comes on, but monitor screen(s) is (are) blank, oscilloscope emits no beeps	<ul style="list-style-type: none"> ■ SO DIMMs incorrectly installed or missing. Missing DIMMs will cause a POST fault and NLX will beep ■ Defective power pc (PPC) board ■ Hold down on-standby button on the PPC, if system boots, replace the power supply
Hard disk drive related symptoms	<ul style="list-style-type: none"> ■ Defective hard disk drive ■ Incorrect hard disk type selected in the BIOS setup ■ Replaceable hard disk drive not installed ■ Power supply failure ■ Corrupted BIOS module firmware, reinstall firmware ■ Hard disk drive not configured as bootable (slave) master hard disk drive ■ Loose cable ■ Faulty riser board ■ Faulty PPC board
CD-ROM related symptoms	<ul style="list-style-type: none"> ■ Defective CD-ROM ■ Defective CD-ROM drive cable ■ Defective CD-ROM board ■ Incorrect CD-ROM configuration in the BIOS setup
Flat panel display blank	<ul style="list-style-type: none"> ■ Display selection jumper set incorrectly on front panel board (there are no jumpers on the board when the oscilloscope is shipped from the factory; this is the correct default setting) ■ Video adapter set to AGP (connect monitor to NLX VGA port, enter BIOS, set Video Adapter = PCI) ■ BIOS setting not Advance > Video Configuration > Primary Video Adapter = PCI ■ Defective cable from front panel board to display adapter board ■ Defective cable from inverter board to display adapter board ■ Defective cable from inverter board to backlighting display lamp ■ Defective backlighting display lamp ■ Faulty display ■ Faulty controller board ■ Faulty inverter board ■ Faulty display adapter board
BIOS error messages	<ul style="list-style-type: none"> ■ Refer to the BIOS error message tables starting on page 6-64

Equipment Required

You will need a digital voltmeter to check power supply voltages, as described on page 6-58.

Testing might also be required to correct some faults. Under those circumstances, you will need the test equipment listed in the *Performance Verification and Adjustment Procedures* in this manual.

Fault Isolation Procedure

Follow the primary troubleshooting tree in Figure 6-31 for fault isolation. This tree calls for you to run the diagnostics programs, and check for BIOS errors.

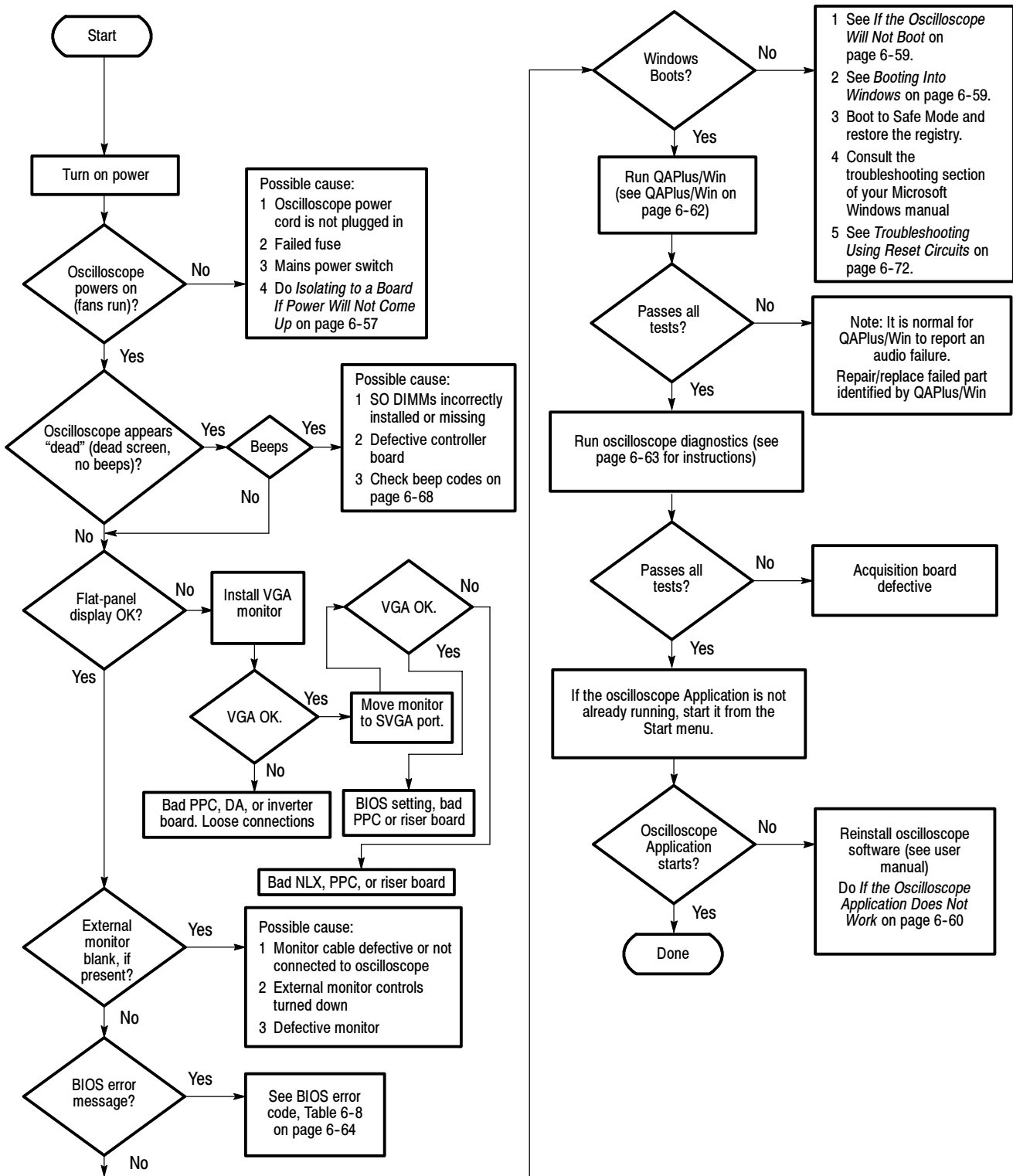

Figure 6-31: Primary troubleshooting tree

Isolating to a Board if Power Will Not Come Up

If the mains power switch is on and the oscilloscope is not on, (power supply is in standby mode), a red light (see Figure 6-32 for its location) is visible through the right side of the oscilloscope. If the oscilloscope is on, the red light is off.

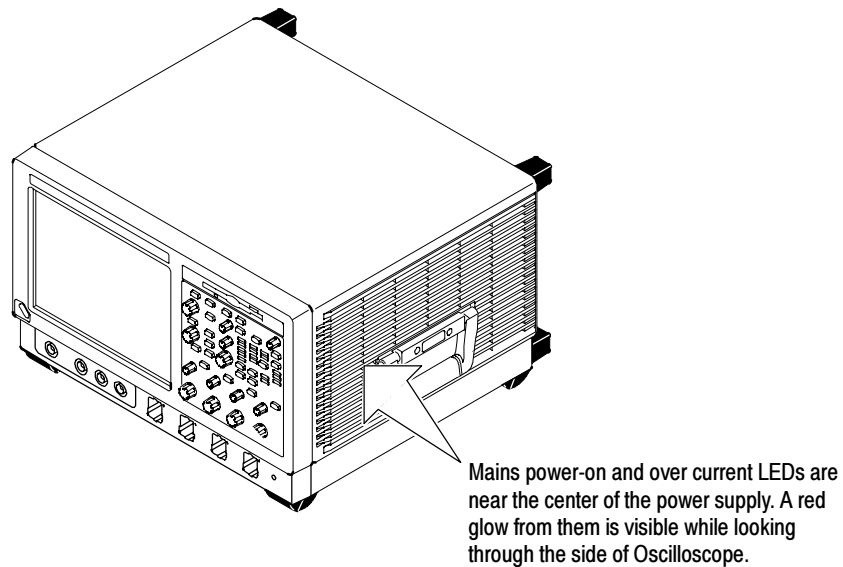

Figure 6-32: Location of power-on and over current LEDs

If the oscilloscope thinks power is on, a red light (see Figure 6-32) means that there is an over current condition.

If the on/standby pin (pin C1 of P201 on the rear power distribution board or pin B162 on the riser board) is low, the oscilloscope thinks power is on.

Remove boards one at a time to locate a fault (the display, floppy, acquisition board, front [analog supply to acquisition board] and power distribution board, the NLX board, and the riser board). If you remove the NLX board, you must jumper the debug power-on pins (see Figure 6-33). The PPC board and the rear power distribution board are required for power to come up.

If removing the boards did not find the problem, replace the power supply.

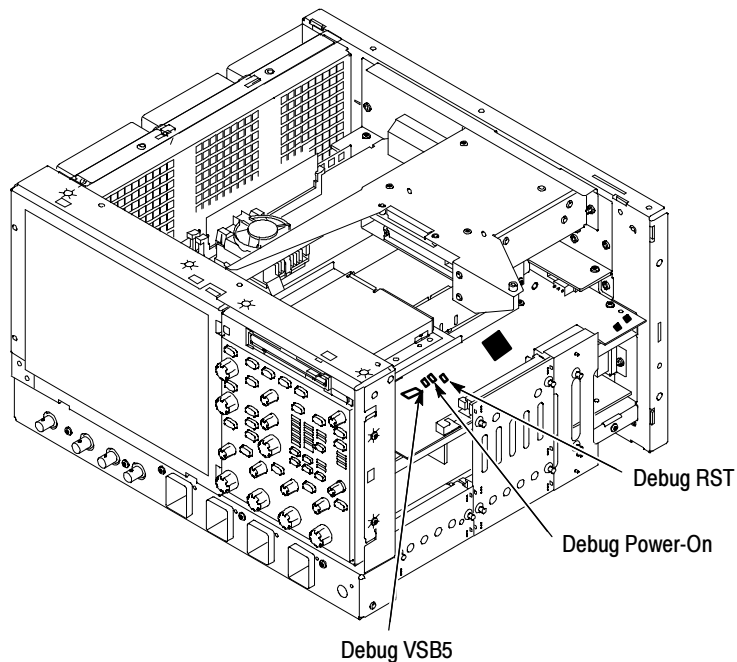

Figure 6-33: Location of debug pins

Checking the Power Supply Voltages

To check the power supply voltages, power on the oscilloscope and connect the reference lead of a digital voltmeter to chassis ground, such as the top of the power supply.

Attach a 0.025 inch square pin to the probe tip of the other lead and insert it into a pin on one of the connectors. The pins that should be carrying voltages are listed in Table 6-5. The location of the J1 and J2 connectors is shown in Figure 6-34 on page 6-59.

Measure the power supply voltages with the voltmeter and compare each reading to the values listed in the tables. If the voltages are within about 5% of the nominal voltages, your power supply is functional.

Table 6-5: Power supply voltages

Front power distribution board (P2) and Power supply (J2)	Voltage	Rear power distribution board (P1) and Power supply (J1)	Voltage	Riser board	Voltage
Pins A/B/C1, 3, 5, 7, 9, 11	+3.3 V	Pins A/B/C5, 6	+12 V	Pin B170	-5 V
Pins A/B/C13	-15 V	Pins A/B/C8, 9, 11, 12, 14, 15, 17	+5 V	Pin A1	-12 V
Pins A/B/C15	+15 V	Pins A/B/C19, 21, 23, 25, 27, 29, 31	+3.3 V	Pin B2	+12 V
Pins A/B/C17, 18, 20, 21, 22	-5 V	Pins B/C3 (fan voltage)	+9.8 V	Pin A5	+3.3 V
Pins A/B/C24, 25, 27, 28, 30, 31	+5 V			Pin A57	+5 V

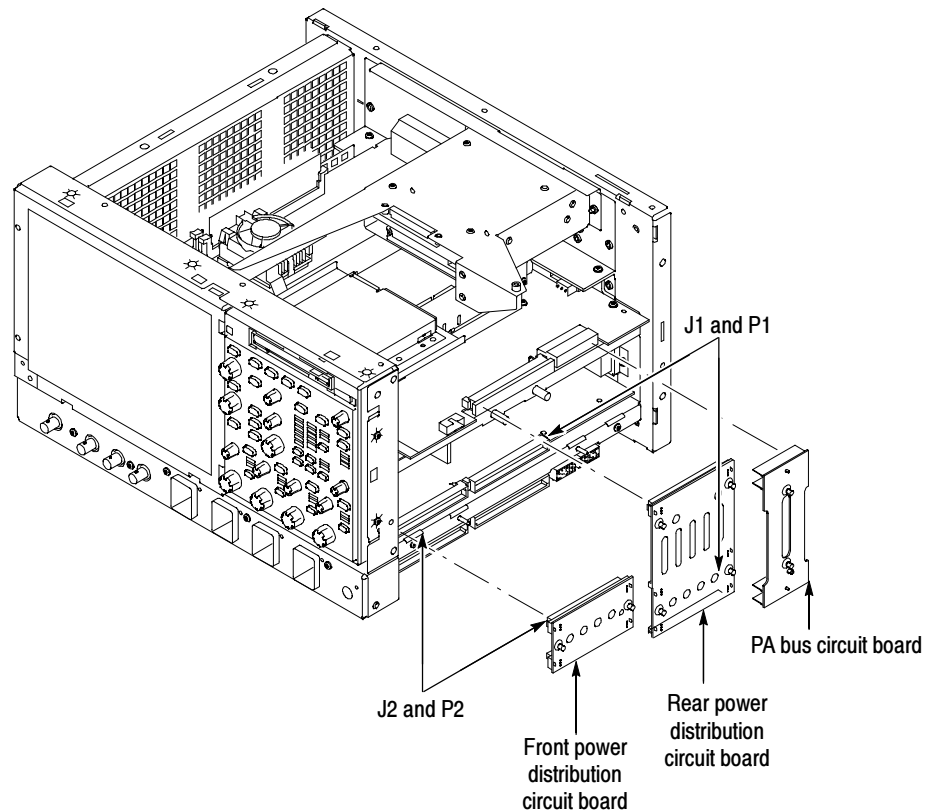

Figure 6-34: Connectors J1 and J2

If the Oscilloscope Will Not Boot

If there is a display on the VGA port, but not on the LCD, replace the display assembly (LCD, lamps, and cable).

If the display adapter is bad, the BIOS should report it using beep codes (see Table 6-10, on page 6-68).

If nothing is displayed, is the display turned on? At boot time and while using an external monitor connected to the NLX external video port, press F2 to enter the BIOS setup. The Advanced Video Configuration menu lets you select PCI (LCD) or AGP (the NLX port on the rear panel). The lower VGA port on the rear panel is the PCI video port (driven by the same video controller as the LCD).

Booting Into Windows

If the oscilloscope will not boot, press F8 to enter the start up menu, and boot to the command prompt. If you can boot to the command prompt, use the MSDOS Edit program to edit the autoexec.bat file to run the CMOS restore utility (see *Update/Restore the NLX Board CMOS* on page 6-75).

If booting starts, finds the hard disk, but hangs displaying the Windows splash screen:

1. Select the AGP video port using the setup menu.
2. Disable the busses and disconnect the PPC board by installing J840 and J841.
3. If the system boots (It will only boot to Windows, the oscilloscope application will not run) to the external NLX video port, replace the PPC board.

**If the Oscilloscope
Application Does Not
Work**

If the oscilloscope boots into Windows, but the oscilloscope application does not work (the DPO Man graphic is displayed), check the following:

1. The application software.
2. The Acquisition board.
3. The PPC board.
4. The Riser board (try removing and reinstalling the Riser board).
5. Did someone exit the application using the Task Manager and then try to reenter the application without re-booting?
6. Set Diagnostic Selection DIP switch 2 to off (see *Dip Switch Controls* on page 6-69 for more information), reboot; check the Diagnostic LED (see page 6-70 for more information).
7. If the relays click, the acquisition is running.
8. Check the desktop properties (right click on the desktop and select Properties). On the Settings tab, 16 bit is required. Video merge will not work with other settings. If you change the setting, reboot.
9. On the Settings tab of the desktop properties, select Advanced and then the Performance tab. Hardware Acceleration must be set to Full for video merge to work. If you change the setting, reboot.

PPC and NLX PC Diagnostics

The primary diagnostics for the oscilloscope are the power-on diagnostics, the QA+Win32 diagnostics, and the oscilloscope diagnostics. Procedures for running these diagnostics are described next.

Power-On Diagnostics

The power-on diagnostics check the basic functionality of the oscilloscope at every power on. If any failures occur at power on, the screen displays the calibration and diagnostics property page. Table 6-6 lists a subset of the power on tests. Use the results of the tests to help you isolate problems to system modules.

The power on tests ensure that hardware is installed and can be accessed by the software. The tests provide limited diagnostic information, but do not provide any performance information. The oscilloscope diagnostics provide more extensive tests than the power-on diagnostics.

The power on tests check the generic hardware including the keyboard, mouse, memory, CPU, and associated peripherals. The interrupt lines and trigger lines are also checked.

If there are no failures, you can view the results of the tests in the Instrument Diagnostics page under the Utilities menu.

Table 6-6: Power-on diagnostic tests

Component	Group & test	Power on	Extended
mainframe	VTC Reset Test	✓	
	VTC Walk1 Test	✓	
	ADG Register Test	✓	
	ADG VXI Addr Test	✓	
	ADG VXI Data Test	✓	
system	Interrupt Lines	✓	✓
	Trigger Lines	✓	✓
Processor	Memory		✓
	PCI Bus		✓
	Registers		✓
Display	Registers		✓
Acquisition	Registers		✓
	Memory		✓
	Acq Modes		✓
	Interrupt		✓
	HF Step		✓
	Vertical		✓
	PLL		✓
Trigger	Registers		✓
	TrgLvlComp		✓
	GTL		✓

Table 6-6: Power-on diagnostic tests (Cont.)

Component	Group & test	Power on	Extended
	Serial I/O		✓
	BTL		✓
	Extended		✓
	Nibble		✓
Misc	GPIB		✓

QAPlus/Win

If the oscilloscope passes all the BIOS tests and Windows boots, the primary tree calls for you to run QAPlus/Win diagnostics software.

QAPlus/Win is a comprehensive diagnostic software application to check and verify the operation of the PC hardware in the oscilloscope.

To run QAPlus/Win, you must have a working keyboard (a working mouse or other pointing device is optional) and have the Windows operating system running. Repair or replace any failed component identified by QAPlus/Win.

NOTE. *To run QAPlus/Win you must have either a working keyboard or a working mouse (or other pointing device) and Windows running.*

To run the QAPlus/Win diagnostic software, do the following steps:

1. Exit the oscilloscope application.
 - a. Display the Task Manager by pressing CTRL, ALT, and Delete.
 - b. Select TDS7000 and then touch **End Task**.
 - c. Display the Task Manager by pressing CTRL, ALT, and Delete.
 - d. Select Windowsscopesseservices and then touch **End TAsk**.
2. Exit all other applications and exit all windows.
3. Click Start → Programs → QAPlus_Win → QAPlus_Win.
4. Touch **OK** and select the tests you want to perform.
5. To restore the oscilloscope to normal operating condition, reboot the oscilloscope after QAPlus/Win diagnostic tests are complete.

Oscilloscope Diagnostics. If the oscilloscope passes all the QAPlus/Win tests, the primary tree calls for you to run the oscilloscope Diagnostics. The oscilloscope Diagnostics are a comprehensive software test that checks the functionality of the oscilloscope. If the oscilloscope Diagnostics test fails, the oscilloscope is defective.

To run the oscilloscope Diagnostics, do the following steps:

1. Turn off all other applications.
2. From the menu bar, touch **Utilities** and then select **Instrument Diagnostics**.

Diagnostics

The oscilloscope has two levels of internal diagnostics that focus on verifying, adjusting, and if need be, isolating faulty modules.

Both levels of internal diagnostics report any bad modules. If a bad module is found, replace the module.

The two levels of diagnostics are the short confidence set and the extended set that tests the oscilloscope circuitry in depth and takes more time. At power on, the oscilloscope automatically executes the short set. The extended set is optional and is executed by using the following procedure:

Prerequisites: Power on the oscilloscope and allow a 20 minute warm-up before doing this procedure.

1. *Display the System diagnostics menu:*
 - a. From the menu bar, touch **Utilities** and then select **Instrument Diagnostics**.

Software Updates

Software updates are easy to do. Simply install the firmware CD in your oscilloscope and follow the displayed instructions or the instructions that accompany the CD.

If you want to order a software update, contact your Tektronix service center.

After Repair

After removal and replacement of a module due to electrical failure, you must perform the adjustment or software update as indicated in Table 6-7.

Table 6-7: Action required for module replaced

Module replaced	Adjustment required	Software update required
Front panel assembly	No	None
Acquisition board	Yes	Boot ROM and authorization code
PPC Processor board	Yes	Boot ROM and authorization code
NLX processor assembly	No	Windows, oscilloscope application
Display panel or display system	No	None
Power supply	Yes	None
Interconnect boards	No	None
Fans	No	None

BIOS Error Messages (Bali NLX)

Table 6-8 lists error messages displayed by the BIOS.

Table 6-8: BIOS Error messages (Bali)

Error message	Explanation
GA20 Error	An error occurred with Gate-A20 when switching to protected mode during the memory test.
Pri Master HDD Error Pri Slave HDD Error Sec Master HDD Error Sec Slave HDD Error	Could not read sector from corresponding drive.
A: Drive Error B: Drive Error	No response from diskette drive.
Cache Memory Error	An error occurred while testing L2 cache. Memory may be bad.
CMOS Battery Low	Replace the batter soon.
CMOS Display Type Wrong	The display type is different than what has been stored in CMOS. Check Setup to make sure type is correct.
CMOS Check Sum Bad	The CMOS checksum is incorrect. CMOS memory may have been corrupted. Run Setup to reset values.
CMOS Settings Wrong	CMOS values are not the same as the last boot. These values have either been corrupted or the battery has failed.
CMOS Date/Time Not Set	The time and/or date values stored in CMOS are invalid. Run Setup to set correct values.
DMA Error	Error during read/write test of DMA controller.

Table 6- 8: BIOS Error messages (Bali) (Cont.)

Error message	Explanation
FDC Failure	Error while trying to access diskette drive controller.
HDC Failure	Error while trying to access hard disk controller.
Update Failed	NVRAM was invalid but was unable to be updated.
Unlock Keyboard	The system keyboard lock is engaged. The system must be unlocked to continue to boot.
Keyboard Error	Error in the keyboard connection. Make sure keyboard is connected properly.
KB/Interface Error	Keyboard interface test failed.
Timer Error	Timer Test failed.
Memory Size Changed	Memory size has changed since the last boot. If no memory was added or removed, then memory may be bad.
Serial presence detect (SPD) device data missing or inconclusive. Do you wish to boot at 100 MHz bus speed? [Y/N]	System memory does not appear to be SPD memory.
No Boot Device Available	System did not find a boot device.
Off Board Parity Error	A parity error occurred on an off-board card. This error is followed by an address.
On Board Parity Error	A parity error occurred in onboard memory. This error is followed by an address.
parity Error	A parity error occurred in onboard memory at an unknown address.
NVRAM/CMOS/PASSWORD cleared by Jumper	NVRAM, CMOS, and passwords have been cleared. The system should be powered off and the jumper removed.
<CTRL_N> Pressed	CMOS is ignored and NVRAM is cleared. User must enter Setup.

BIOS Error Messages (Radisys NLX)

When the NLX board powers-on, the BIOS runs power-on-self-tests to check the board. The BIOS writes error codes to location 80h and tries to write the codes to the display. If the error is fatal, then the error code indicates the last successful checkpoint reached. Table 6-9 lists the error messages displayed by the Radisys BIOS.

Once the display is enabled, errors are written to the display as text messages. These messages are always displayed unless the board is configured for silent boot or headless (no keyboard, mouse, or display) operation.

Table 6-9: BIOS Error messages (Radisys)

Displayed error code	Error message	Displayed error code	Error message
02h	Verify real mode	6Ch	Display shadow message
03h	Disable NMI	6Eh	Display non-disposable segments
04h	Get CPU type	70h	Display error messages
06h	Initialize system hardware	72h	Check for configuration errors
08h	Initialize chipset registers with initial POST values	74h	Test real-time clock
09h	Set POST flag	76h	Check for keyboard errors
0Ah	Initialize CPU registers	7Ah	Test for key lock on
0Bh	Enable CPU cache	7Ch	Set up hardware interrupt vectors
0Ch	Initialize cache to initial POST values	7Eh	Test coprocessor if present
0Eh	Initialize I/O	80h	Disable on-board I/O ports
0Fh	Initialize local bus IDE	81h	Late device initialization
10h	Initialize power management	82h	Detect and install external RS-232 ports
11h	Load alternate registers with initial POST values	83h	Configure IDE controller
12h	Restore CR0	84h	Detect and install external parallel ports
13h	Reset PCI BM	85h	Initialize PCI PCC devices
14h	Initialize keyboard controller	86h	Reinitialize on-board I/O ports
16h	BIOS ROM checksum	87h	Configure MCD devices
17h	Presize DRAM	88h	Initialize BIOS data area
18h	8254 timer initialization	89h	Initialize NMI
1Ah	8237 DMA controller initialization	8Ah	Initialize extended BIOS data area
1Ch	Reset programmable interrupt controller	8Bh	Initialize mouse
20h	Test DRAM refresh	8Ch	Initialize floppy controller
22h	Test 8742 keyboard controller	8Eh	Execute auto-typing
24h	Set ES segment register to 4GB	8Fh	Hard disk controller fast preinitialization
26h	Enable A20	90h	Initialize hard disk controller
28h	Auto-size DRAM	91h	Initialize local bus hard disk controller
29h	Initialize PMM	92h	Jump to User-Patch2
2Ah	Clear 512 Kb base RAM	93h	Build MPTABLE for multiprocessor boards
2Ch	Test 512 Kb base address lines	95h	Install CD-ROM for boot
2Eh	Test low byte of 512 Kb base memory	96h	Clear huge ES segment register
2Fh	Pre-system shadow	97h	Fix up MP table
30h	Test high byte of 512 Kb base memory	98h	Search for option ROMs (beep for bad checksum)
32h	Test CPU bus-clock frequency	99h	Check for SMART HDD
33h	Initialize PDM	9Ah	Shadow option ROMs

Table 6-9: BIOS Error messages (Radisys) (Cont.)

Displayed error code	Error message	Displayed error code	Error message
34h	Test CMOS RAM	9Ch	Set up power management
35h	Initialize alternate chipset registers	9Dh	Initialize security
36h	Warm start shutdown entry point	9Eh	Enable hardware interrupts
37h	Re-initialize the chipset	9Fh	HDD fast initialization (second)
38h	Shadow system BIOS ROM	A0h	Set time of day
39h	Reinitialize the cache	A2h	Check key lock
3Ah	Auto-size cache	A4h	Initialize typematic rate
3Ch	Configure advanced chipset registers	A8h	Erase F2 prompt
3Dh	Load alternate registers with CMOS values	AAh	Scan for F2 keystroke
3Eh	Read HW	ACh	Enter SETUP
40h	Set Initial CPU speed	A Eh	Clear in-POST flag
42h	Initialize interrupt vectors	B0h	Check for errors
44h	Initialize BIOS interrupts	B2h	POST done--prepare to boot operating system
45h	Core device initialization	B4h	One beep before boot
46h	Check ROM copyright notice	B5h	Quiet boot end/display MultiBoot menu
48h	Check video configuration against CMOS	B6h	Check password (optional)
49h	Initialize PCI bus and devices	B8h	Clear global descriptor table
4Ah	Initialize all video adapters in system	B9h	Prepare to boot
4Bh	Display Quiet-Boot screen	BAh	DMI
4Ch	Shadow video BIOS ROM	BBh	Initialize BCVS
4Eh	Display copyright notice	BCh	Clear parity checkers
50h	Display CPU type and speed	BDh	Boot Menu
51h	Initialize EISA board	BEh	Clear screen (optional)
52h	Test Keyboard	BFh	Check virus and backup reminders
54h	Set key click if enabled	C0h	Try to boot with INT19
56h	Enable keyboard	C1h	Initialize PEM
58h	Test for unexpected interrupts	C2h	PEM log
59h	Initialize PDS	C3h	PEM display
5Ah	Display prompt "Press F2 to enter SETUP"	C4h	PEM system error initialization
5Bh	CPU cache off	C5h	Dual CMOS
5Ch	Test RAM between 512 Kb and 640 Kb	C6h	Docking initialization
5Eh	Base address	C7h	Late docking initialization
60h	Test extended memory	D0h	Interrupt handler error
62h	Test extended memory address lines	D2h	Unknown interrupt error

Table 6-9: BIOS Error messages (Radisys) (Cont.)

Displayed error code	Error message	Displayed error code	Error message
64h	Jump to User-Patch1	D4h	Pending interrupt error
66h	Configure advanced cache registers	D6h	Initialize option ROM error
68h	Enable external and CPU caches	D8h	Shutdown error
69h	PM set up SMM	DAh	Extended block move
6Ah	Display external cache size	DCh	Shutdown 10 error
6Bh	Load custom defaults		

BIOS Beep Codes (Bali NLX)

When an error occurs during the power on self test (POST), the BIOS displays an error message describing the problem. The BIOS also issues a beep code (one long tone followed by two short tones) during POST if the video configuration fails (a faulty video card or no card installed) or if an external ROM module does not properly checksum to zero.

An external ROM module (for example, a video BIOS) can also issue audible errors, usually consisting of one long tone followed by a series of short tones. For more information on the beep codes, check the documentation for the device.

There are several POST routines that issue a POST terminal error and shut down the system if they fail. Before shutting down the system, the terminal-error handler issues a beep code (see Table 6-10) signifying the test point error, writes the error to I/O port 80h, attempts to initialize the video, and writes the error in the upper left corner of the screen (using both monochrome and color adapters).

If the POST completes normally, the BIOS issues one short beep before passing control to the operating system.

Table 6-10: Beep codes (Bali)

Beeps	Description
1	Refresh failure
2	Parity cannot be reset
3	First 64 K memory failure
4	Timer not operational
5	Processor failure (not used)
6	8042 Gate A20 cannot be toggled
7	Exception interrupt error

Table 6-10: Beep codes (Bali) (Cont.)

Beeps	Description
8	Display memory R/W error
9	ROM checksum error (not used)
10	CMOS shutdown register test error
11	Invalid BIOS (for example, POST module not found, etc.)

BIOS Beep Codes (Radisys NLX)

When the NLX board powers-on a number of the BIOS checkpoints generate an audible 'beep' code on failure using the standard PC speaker (also routed through the board audio system). The beep codes are made up of up to 4 groups of short beeps and are listed in Table 6-11.

If your instrument does not contain a speaker, attach a speaker to the display-adaptor board square pins to hear the codes.

Table 6-11: Beep codes (Radisys)

Check-point code	Error message	Beep code
16h	BIOS ROM checksum	1-2-2-3
20h	Test DRAM refresh	1-3-1-1
22h	Test 8742 keyboard controller	1-3-1-3
2Ch	Test 512 Kb base address lines	1-3-4-1
2Eh	Test low byte of 512 Kb base memory	1-3-4-3
46h	Check ROM copyright notice	2-1-2-3
58h	Test for unexpected interrupts	2-2-3-1
98h	Search for option ROMs (beep for bad checksum)	1-2
B4h	One beep before boot	1

Dip Switch Controls

Dip switch is used to direct program flow during power on self test (POST). A switch set to ON is closed and presents a low state (0 V) to the switch buffer. This is the default switch position. A switch set to OFF is open and presents a high state (3.3 V) to the switch buffer. This is the 'set' position. Table 6-12 describes the switch functions.

Table 6- 12: DIP switch functions

Switch	Test option		
	Default	Set	Description
1	1 Meg RAM test	32 Meg RAM test	POST does not know how much DRAM is installed in the board.
2	Enable phase 2 POST	Disable phase 2 POST	Use to disable phase 2 of POST.
3	Do not loop on phase 2 POST	Loop on entire phase 2 POST	This switch is checked at every loop iteration, so it is possible to break out of this loop by moving switch 3 to the default position. You can not loop on a single passing test.
4	Allow debug output	Suppress debug output	Used by the console. Checked at every write operation.
5	Loop on failing test	Continue past failing test	If a test fails (except DRAM march test) and switch 6 is set, this switch is checked. You can break out of the loop by moving switch 5 to the set position, removing the fault, or by setting switch 6 to the default position.
6	Stop on failing test	Continue past failing test	If set and a test fails, the program checks switch 5. If not set, the program will stop on a failure by branching to a loop. To exit the loop, reset the power PC.
7	Do not cycle application diagnostics	Application diagnostic cycle	If set, the power-on diagnostics cycle, which prevents completion of the boot sequence.
8	Do not force power-up diagnostics	Forces power-up diagnostics	At power-on this switch is checked, and if set, power-up diagnostics will run.

Diagnostic LED

Table 6-13 lists the actions performed at power-up of the power pc (PPC) and the associated display on the diagnostic LED. Until the MPC106 is initialized the LED is not active. RESET forces the display to .8. H, L, P, and a blinking - indicate where the program is in the power-up sequence. As tests occur, the associated number is displayed on the LED. A failing test displays a decimal point and the test number.

Table 6-13: Diagnostic LED

LED	Diagnostic status		
	Passed test	Testing	Test method
.8		MPC740 initialization, MPC106 walking one test, or MPC106 configuration test	Walk a one through configuration register. Use addresses FEC00000 and FEE00000. A one is walked through the lower data bus. Requests the vendor identifier. Use addresses FEC00000 and FEE00000. Vendor identifier data is presented on the lower data bus. Data 0x0face106 is written to the MPC740 register gpr2 if the correct vendor identifier is returned. If the incorrect identifier is returned, data 0x01bad106 is written to the register.
0	MPC740 initialization, MPC106 walking one test, or MPC106 configuration test	First PCI access test and UART initialize	This is not a pass/fail test, only an attempt to read the PCI bus. Read the configuration space of the SIO. The SIO should return the vendor/device identifier (0x00021057), within MPC740 gpr2 register. No data comparison or fault determination occurs. DIP switches are not checked. Set UART to 9600, n, 8, 1. No testing or fault reporting is performed. Once completed, console is usable. Dip switches are not checked.
1	First PCI access test and UART initialize	PC87560 walking-one	Walk a one through the configuration register. Walk a one through the AD bus.
2	PC87560 walking-one	PC87560 configuration	Request vendor/device identifier. Data 0x0face560 is written to MPC740 register gpr6 if correct identifier is returned. If incorrect identifier is returned, data 0x01bad560 is written to MPC740 register gpr6.
3	PC87560 configuration	DEC21554 configuration	Request vendor/device identifier. Data 0x0face215 is written to MPC740 register gpr6 if correct identifier is returned. If incorrect identifier is returned, data 0x01bad215 is written to MPC740 register gpr6.
4	DEC21554 configuration	RS232 interface test	Send UUUUUUUU (55hex, 1010101 binary) to console.
5	RS232 interface test	ROM checksum	Calculate device checksum and compare with checksum in ROM.
6	ROM checksum	DRAM cell test with cache	Test address lines. Write patterns to address range set by switch 1. From start address (00000000) to end address, write hex pattern aaaaaaaa. Repeat for hex patterns cccccccc and f0f0f0f0.
7	DRAM cell test with cache	DRAM march test with out cache	DRAM march test. Test data lines. Write to address range set by switch 1. Cache is disabled.
8	DRAM march test with out cache	DRAM march test with cache	Test data lines. Write to address range set by switch 1.
9	DRAM march test with cache	DRAM walking one	Test data lines. Walk a one through DRAM memory location. Cache is disabled. Walk a one through buss MEM_DL.
A	DRAM walking one	NVRAM walking one	Walk a one through NVRAM memory location. Cache is disabled. Walk a one through bus XPC_ISA_D.
H	POST passed		

Table 6- 13: Diagnostic LED (Cont.)

LED	Passed test	Testing	Test method
L		Boot parameters loaded and waiting for host	Program has loaded boot parameters and is waiting to connect to host.
P		Loading files from host	Program has connected to host and is loading oscilloscope files.
—	Load process complete		Files have completed loading.

Troubleshooting Using Reset Circuits

The Power PC (PPC) board uses a combination of removable jumpers and surface mount resistors to manipulate circuit reset for troubleshooting.

There are three PCI busses on the PPC board, the NLX primary PCI bus, L2 PCI bus, and the embedded PPC PCI bus. A hardware fault on any of these busses can prevent Windows from starting properly.

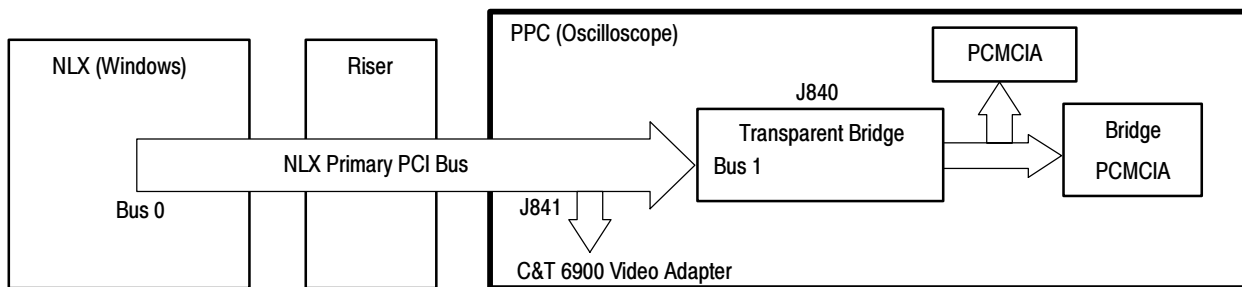

Figure 6- 35: The three PCI busses

Using jumpers J840 and J841 (see Figure 6-37 on page 6-74) you can selectively remove components from the NLX primary PCI bus. This is useful when Windows will not start. The PPC board components on the NLX primary PCI bus are the DIGITAL 21150 transparent bridge, and the C&T 6900 video adapter.

Installing J840 forces the transparent bridge, all components on the L2 PCI bus, and all components on the PPC PCI bus into reset. If this allows Windows to start, you will need to eliminate the PPC PCI bus. The easiest way to force the PPC PCI bus into reset is to press and hold the PPC reset button, S900. So, remove J840, and holding the reset button, determine if the instrument will boot to Windows.

Installing J841 removes the C&T 6900 from the Windows side. Note, neither the PPC ECB VGA port or the LCD will function if J841 is installed. Use the NLX SVGA port (see Figure 6-36).

NOTE. The C&T 6900 video adapter located on the Tektronix PPC board is the primary video adapter. A second video adapter, the RAGE 2C, is located on the NLX board. The RAGE is an AGP video adapter and the C&T 6900 is a PCI bus video adapter. The C&T 6900 is made the primary video adapter because it can drive LCD panels. Tektronix forces the C&T 6900 to be the primary video adapter via BIOS setting Advance→ Video Configuration→ Primary Video Adapter = PCI.

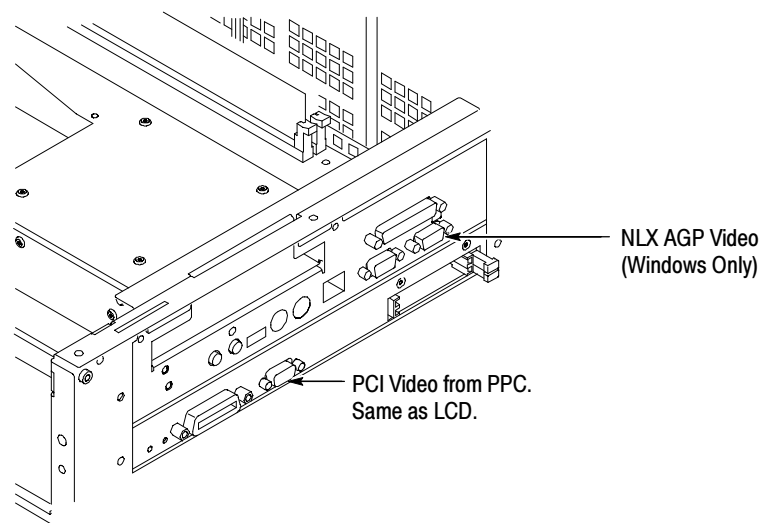

Figure 6-36: PCI and NLX video connectors

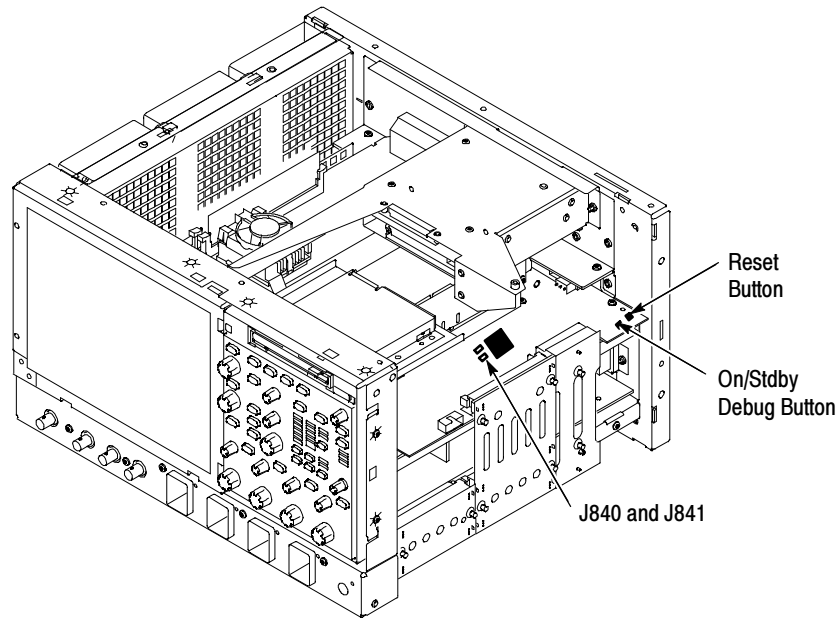

Figure 6-37: Location of jumpers and reset button

Installing the Processor Board Serial Number

To install a serial number into the oscilloscope do the following steps:

1. Connect a PC with a GPIB interface to the GPIB interface of the oscilloscope.



WARNING. Make sure the unique identifier does not end in all zeros before generating or setting the key.

2. Use the following command to install the serial number (the actual serial number should be in single quotes):

```
:HWAccountant:SERIAL 'serialNumber'
```

3. After sending this command, reboot the instrument. After rebooting, a valid unique identifier (UID) is available.

Update/Restore the NLX Board CMOS

If the CMOS parameters become corrupted, restore the CMOS memory using the following procedure:



CAUTION. *Only install CMOS parameters from Tektronix. CMOS parameters from other manufactures my make your oscilloscope inoperable.*

1. Edit the autoexec.bat file.
2. Remove comments CMOS restore parameters.
3. Boot the instrument.
4. Re-edit the autoexec.bat file to re-comment the CMOS restore parameters.

If you cannot restore the CMOS memory, replace the battery.

Installing an Authorization Key

If you replace your PPC board or add a new options, you must install a new authorization key. Install the authorization key using the following procedure:

1. From the oscilloscope menu bar, touch the **Utilities** menu, select **Option Installation**, and then touch **Continue**.
2. Enter the new key using an attached keyboard.
3. Touch **Continue**.

Hard Disk Drive Maintenance

Use the same procedures to maintain the oscilloscope hard disk drive that you use to maintain a hard disk drive in a personal computer.

Using ScanDisk, attempt to fix the disk without destroying data on the disk. To use ScanDisk, perform the following steps:

1. Remove the hard disk drive from the oscilloscope.
2. Install the hard disk drive into personal computer.

3. Power up the computer and run ScanDisk. Set Scandisk to perform a thorough surface scan and to automatically fix errors.
 - Using Microsoft Windows 98: select Start\Programs\Accessories\System Tools\ScanDisk
 - Using Microsoft MSDOS: enter SCANDISK *drive:* /SURFACE /AUTOFIX
4. If ScanDisk will not repair the disk, format the hard disk drive using the File Utilities Format command. Format will destroy all data currently on the disk.
5. If reformatting the hard disk and reloading the software will not repair the disk, install a new hard disk drive.

Repackaging Instructions

This section contains the information needed to repack the oscilloscope for shipment or storage.

Packaging

When repacking the oscilloscope for shipment, use the original packaging. If the packaging is unavailable or unfit for use, contact your local Tektronix representative to obtain new packaging.

Seal the shipping carton with an industrial stapler or strapping tape.

Shipping to the Service Center

Contact the Service Center to get an RMA (return material authorization) number, and any return or shipping information you may need.

If the oscilloscope is being shipped to a Tektronix Service Center, enclose the following information:

- The RMA number.
- The owner's address.
- Name and phone number of a contact person.
- Type and serial number of the oscilloscope.
- Reason for returning.
- A complete description of the service required.

Mark the address of the Tektronix Service Center and the return address on the shipping carton in two prominent locations.

Options

This section lists the standard and optional accessories available for the oscilloscope, as well as the product options.

Accessories

This section lists the standard and optional accessories available for this oscilloscope.

Standard The following accessories are shipped with the oscilloscope:

Table 7-1: Standard accessories

Accessory	Part number
Graphical Packing List (Read Me First)	071-1061-xx
User Manual	071-7012-xx
Quick Reference Manual (8 languages)	020-2426-xx
Product Software CD	063-3541-xx
Operating System Restore CD	063-3377-xx
Optional Applications Software CD	063-3478-xx
Online Help (part of the application software)	—
Performance Verification (a pdf file on the Product Software CD)	—
Programmer Online Guide (files on the Product Software CD)	—
NIST, MIL-STD-45662A and ISO9000 Calibration Certificate	—
Four TekConnect-to-SMA adapters	TCA-SMA
U.S. Power Cord	161-0104-xx
Deskew Fixture, with instructions	067-0484-00
Mouse	119-6298-xx
Front Cover	200-4653-xx
Accessory Pouch	016-1441-xx
Important Documents Folder with Microsoft Windows license	—

Optional The accessories in Table 7-2 are orderable for use with the oscilloscope at the time this manual was originally published. Consult a current Tektronix catalog for additions, changes, and details.

Table 7-2: Optional accessories

Accessory	Part number
Service Manual	071-7021-xx
Transit Case	016-1522-xx
Scope Cart	K4000 (Option 1K)
P6246 400 MHz differential probe ¹	P6246
P6247 1.0 GHz differential probe ¹	P6247
P6248 1.5 GHz differential probe ¹	P6248
P6249 4 GHz differential probe ¹	P6249
P6330 differential 3 GHz probe	P6330
P7240 active 4 GHz probe	P7240
P7330 differential 3.5 GHz probe ¹	P7330
TekConnect-to-SMA adapter	TCA-SMA
TekConnect-to-BNC adapter	TCA-BNC
TekConnect-to-N adapter	TCA-N
Wavewriter: AWG and waveform creation software	S3FT400
WSTRO WaveStar Software	WSTRO
GPIB cable (1 m)	012-0991-01
GPIB cable (2 m)	012-0991-00
USB Keyboard	119-6633-xx
Small Keyboard, fits into pouch, PS2 interface	118-9402-xx
Replacement hard disk	650-4328-xx

¹ **Requires TCA-BNC TekConnect BNC adapter**

NOTE. The P6339A is not supported by this oscilloscope.

Options

The following options can be ordered for the oscilloscope:

- Option 1K: K4000 Instrument Cart
- Option 1R: Rack Mount Kit (includes: hardware and instructions for converting to rackmount configuration)
- International Power Cords Options:
 - Option A1 - Universal European 220 V, 50 Hz
 - Option A2 - United Kingdom 240 V, 50 Hz
 - Option A3 - Australian 240 V, 50 Hz
 - Option A5 - Switzerland 220 V, 50 Hz
 - Option AC - China 220 V, 50 Hz
 - Option A99 - No power cord
- Option J1: TDSJITX Jitter analysis application with documentation
- Option USB - USB2.0 Test application with documentation
- Option SM - Mask testing with documentation
- Option ST - Serial pattern triggering with documentation
- Option TDS6UP - Field upgrade options. Many are available; contact Tektronix (see page xvii) for a complete list of available TDS7UP options with installation instructions
- Service offerings:
 - Opt. C3: Calibration services extended to cover three years
 - Opt. C5: Calibration services extended to cover five years
 - Opt. D1: Calibration data report
 - Opt. D3: Test Data for calibration services in Opt. C3
 - Opt. D5: Test Data for calibration services in Opt. C5
 - Opt. R3: Repair warranty extended to cover three years
 - Opt. R5: Repair warranty extended to cover five years

Electrical Parts List

The modules that make up this instrument are often a combination of mechanical and electrical subparts. Therefore, all replaceable modules are listed in Section 10, *Mechanical Parts List*. Refer to that section for part numbers when using this manual.

Diagrams

This section describes the electrical operation of the TDS6000 Digital Storage Oscilloscope and modules using the major circuit blocks or modules. Figure 9-1 on page 9-2 shows the oscilloscope module interconnections.

Symbols

Graphic symbols and class designation letters are based on ANSI Standard Y32.2-1975. Abbreviations are based on ANSI Y1.1-1972.

Logic symbology is based on ANSI/IEEE Std 91-1984 in terms of positive logic. Logic symbols depict the logic function performed and can differ from the manufacturer's data.

The tilde (~) preceding a signal name indicates that the signal performs its intended function when in the low state.

Other standards used in the preparation of diagrams by Tektronix, Inc. are:

- Tektronix Standard 062-2476 Symbols and Practices for Schematic Drafting
- ANSI Y14.159-1971 Interconnection Diagrams
- ANSI Y32.16-1975 Reference Designations for Electronic Equipment
- MIL-HDBK-63038-1A Military Standard Technical Manual Writing Handbook

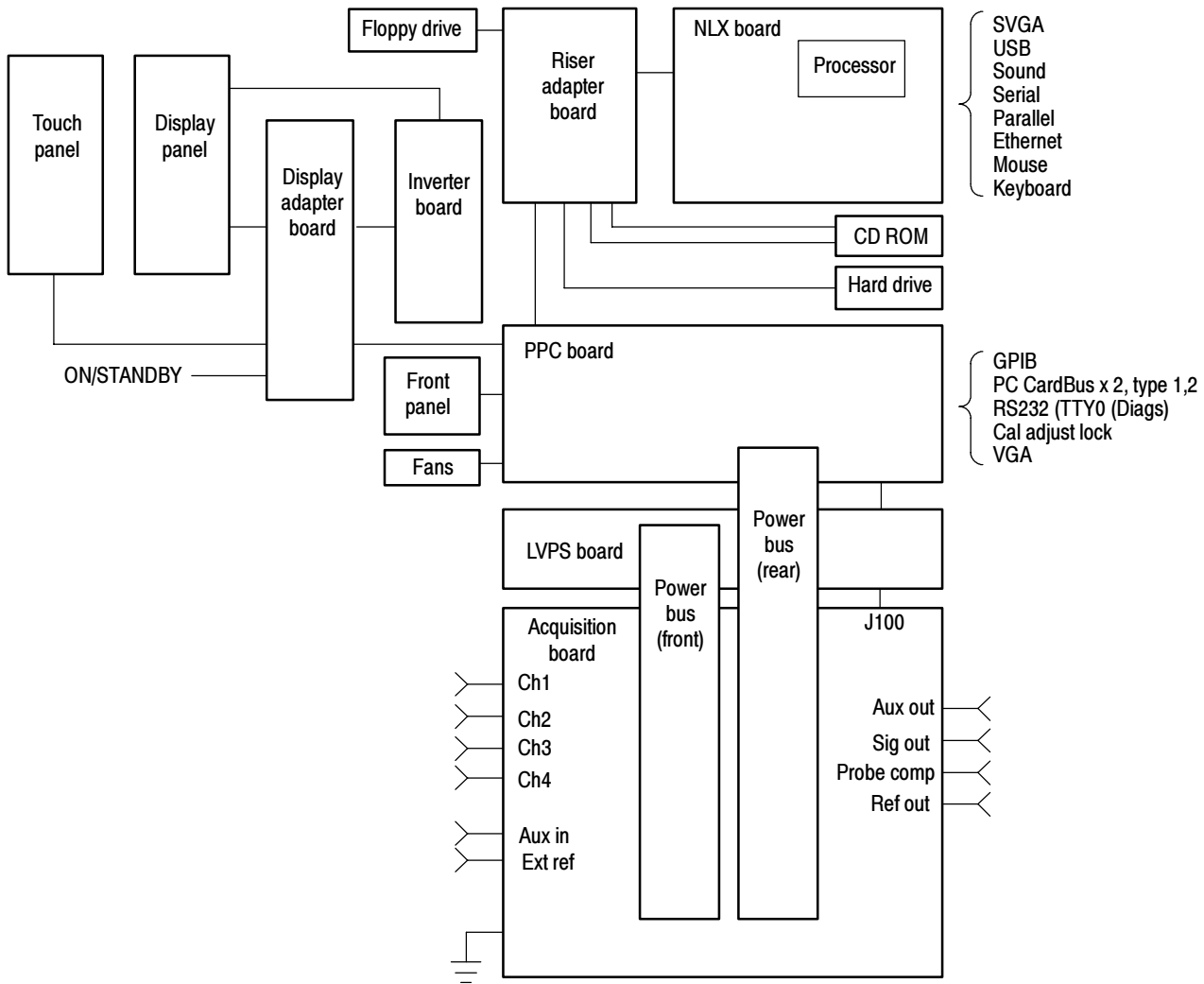

Figure 9- 1: TDS7000 series block diagram

Mechanical Parts List

This section contains a list of the replaceable modules for the oscilloscope. Use this list to identify and order replacement parts.

Parts Ordering Information

Replacement parts are available through your local Tektronix field office or representative.

Changes to Tektronix instruments are sometimes made to accommodate improved components as they become available and to give you the benefit of the latest circuit improvements. Therefore, when ordering parts, it is important to include the following information in your order.

- Part number
- Instrument type or model number
- Instrument serial number
- Instrument modification number, if applicable

If you order a part that has been replaced with a different or improved part, your local Tektronix field office or representative will contact you concerning any change in part number.

Module Servicing

Modules can be serviced by selecting one of the following three options. Contact your local Tektronix service center or representative for repair assistance.

Module Exchange. In some cases you may exchange your module for a remanufactured module. These modules cost significantly less than new modules and meet the same factory specifications. For more information about the module exchange program, call 1-800-833-9200, select option 2.

Module Repair and Return. You may ship your module to us for repair, after which we will return it to you.

New Modules. You may purchase replacement modules in the same way as other replacement parts.

Using the Replaceable Parts List

This section contains a list of the mechanical and/or electrical components that are replaceable for the oscilloscope. Use this list to identify and order replacement parts. The following table describes each column in the parts list.

Parts list column descriptions

Column	Column name	Description
1	Figure & Index Number	Items in this section are referenced by component number.
2	Tektronix Part Number	Use this part number when ordering replacement parts from Tektronix.
3 and 4	Serial Number	Column three indicates the serial number at which the part was first effective. Column four indicates the serial number at which the part was discontinued. No entries indicates the part is good for all serial numbers.
5	Qty	This indicates the quantity of parts used.
6	Name & Description	An item name is separated from the description by a colon (:). Because of space limitations, an item name may sometimes appear as incomplete. Use the U.S. Federal Catalog handbook H6-1 for further item name identification.
7	Mfr. Code	This indicates the code of the actual manufacturer of the part. (Code to name and address cross reference is located after this page.)
8	Mfr. Part Number	This indicates the actual manufacturer's or vendor's part number.

Abbreviations

Abbreviations conform to American National Standard ANSI Y1.1-1972.

Mfr. Code to Manufacturer Cross Index

The following table cross indexes codes, names, and addresses of manufacturers or vendors of components listed in the parts list.

Manufacturers cross index

Mfr. code	Manufacturer	Address	City, state, zip code
00779	AMP INC.	CUSTOMER SERVICE DEPT PO BOX 3608	HARRISBURG, PA 17105-3608
01295	TEXAS INSTRUMENTS INC	SEMICONDUCTOR GROUP 13500 N CENTRAL EXPRESSWAY PO BOX 655303	DALLAS, TX 75272-5303
01KV9	MERIX CORP	1521 POPLAR LANE PO BOX 3000	FOREST GROVE, OR 97116
01963	CHERRY ELECTRICAL PRODUCTS CO	3600 SUNSET AVENUE	WAUKEGAN, IL 60087-3214
03ZT7	MOBILE PLANET	9175 DEERING AVE	CHATSWORTH, CA 91311
04713	MOTOROLA INC	SEMICONDUCTOR PRODUCTS SECTOR 5005 E MCDOWELL ROAD	PHOENIX, AZ 85008-4229
049S6	FUJITSU COMPUTER PRODUCTS OF AMERICA INC	2904 ORCHARD PARKWAY	SAN JOSE, CA 95134-2009

Manufacturers cross index (cont.)

Mfr. code	Manufacturer	Address	City, state, zip code
05791	LYN-TRON INC	SOUTH 6001 THOMAS MALLEN RD	SPOKANE, WA 99204
060D9	UNITREK CORPORATION	3000 COLUMBIA HOUSE BLVD, SUITE 1 20	VANCOUVER, WA 98661
06666	GENERAL DEVICES	PO BOX 39100	INDIANAPOLIS, IN 46239
06915	RICHCO	5825 N TRIPP AVE P.O. BOX 804238	CHICAGO, IL 60646
07416	NELSON NAME PLATE COMPANY	3191 CASITAS AVENUE	LOS ANGELES, CA 90039-2410
0ADN8	DELTA PRODUCTS CORP-DPZ	4405 CUSHING PARKWAY	FREMONT, CA 94538
0B0A9	DALLAS SEMICONDUCTOR	4350 BELTWOOD PKWY S	DALLAS, TX 75244
0GZV8	HUBER & SUHNER INC	19 THOMPSON DRIVE	ESSEX JUNCTION, VT 05452-3408
0J9P9	GEROME MFG CO INC	PO BOX 737 403 NORTH MAIN	NEWBERG, OR 97132
0KB01	STAUFFER SUPPLY CO	810 SE SHERMAN	PORTLAND, OR 97214-4657
0KB05	NORTH STAR NAMEPLATE INC	5750 NE MOORE COURT	HILLSBORO, OR 97124-6474
0KBZ5	Q & D PLASTICS INC	1812 - 16TH AVENUE PO BOX 487	FOREST GROVE, OR 97116-0487
12136	PHC INDUSTRIES INC	1643 HADDON AVE PO BOX 1448	CAMDEN, NJ 08103
16179	M/A COM INC	1011 PAWTUCKER BLVD. PO BOX 3295	LOWELL, MA 01853-3295
1AW87	LEWIS SCREW CO.	4300 SOUTH RACINE AVENUE	CHICAGO, IL 60609
1DM20	PARLEX CORP	7 INDUSTRIAL WAY	SALEM, NH 03079
20944	ANRITSU COMPANY	685 JARVIS DRIVE	MORGAN HILLS, CA 95037
22526	FCI/BERG ELECTRONICS INC	825 OLD TRAIL ROAD	ETTERS, PA 17319-9769
22670	GM NAMEPLATE INCORPORATED	2040 15TH AVE WEST	SEATTLE, WA 98119-2783
24931	FCI/BERG ELECTRONICS INC	RF/COAXIAL DIV 2100 EARLYWOOD DR PO BOX 547	FRANKLIN, IN 46131
26003	MARTEK POWER MDI	4115 SPENCER STREET	TORRANCE, CA 90503-2489
26805	M/A COM OMNI SPECTRA INC	MICROWAVE CONNECTOR DIV 140 4TH AVE	WALTHAM, MA 02254
2K262	BOYD CORPORATION	6136 NE 87TH AVENUE	PORTLAND, OR 97220
2W733	BELDEN WIRE & CABLE COMPANY	2200 US HWY 27 SOUTH PO BOX 1980	RICHMOND, IN 47374
32559	BIVAR INC	4 THOMAS ST	IRVINE, CA 92718
34649	INTEL CORPORATION	3065 BOWERS PO BOX 58130	SANTA CLARA, CA 95051-8130
3M099	PORTLAND SCREW COMPANY	6520 N BASIN AVE	PORTLAND, OR 97217
46628	LOGITECH INC	6505 KAISER DR	FREMONT, CA 94555
50356	TEAC AMERICA INC	7733 TELEGRAPH RD PO BOX 750	MONTEBELLO, CA 90640-6537
5Y400	TRIAx METAL PRODUCTS INC	1880 SW MERLO DRIVE	BEAVERTON, OR 97006

Manufacturers cross index (cont.)

Mfr. code	Manufacturer	Address	City, state, zip code
61058	MATSUSHITA ELECTRIC CORP OF AMERICA	PANASONIC INDUSTRIAL CO DIV TWO PANASONIC WAY	SECAUCUS, NJ 07094
64537	KDI/TRIANGLE CORPORATION	60 S JEFFERSON RD	WHIPPANY, NJ 07981
6Y440	MICRON SEMICONDUCTOR PRODUCTS INC	8000 S FEDERAL WAY PO BOX 6	BOISE, ID 83707-0006
71400	BUSSMANN	DIVISION COOPER INDUSTRIES INC PO BOX 14460	ST LOUIS, MO 63178
74594	COMPONENT RESOURCES INC	BUSSMAN PARTS C/O CASEY LAKEY 14525 SW WALKER ROAD	BEAVERTON, OR 97006
75915	LITTELFUSE INC	800 E NORTHWEST HWY	DES PLAINES, IL 60016-3049
76096	ELMA ELECTRONICS INC	41440 CHRISTY ST	FREMONT, CA 94538
78189	SHAKEPROOF	DIVISION OF ILLINOIS TOOL WORK ST. CHARLES ROAD	ELGIN, IL 60120
7X318	KASO PLASTICS INC	5720-C NE 121ST AVE, STE 110	VANCOUVER, WA 98682
80009	TEKTRONIX INC	14150 SW KARL BRAUN DR PO BOX 500	BEAVERTON, OR 97077-0001
86928	SEASTROM MFG CO INC	456 SEASTROM STREET	TWIN FALLS, ID 83301
8X345	NORTHWEST SPRING MFG CO	5858 WILLOW LANE	LAKE OSWEGO, OR 97035
93907	CAMCAR DIV OF TEXTRON INC	ATTN: ALICIA SANFORD 516 18TH AVE	ROCKFORD, IL 611045181
94222	SOUTHCO, INC.	210 N BRINTON LAKE RD	CONCORDVILLE, PA 19331
S5769	NEC CORPORATION	NEC BUILDING 7-1, SHIBA 5 CHOME MINATO-KU	TOKYO, JP 108
TK0588	UNIVERSAL PRECISION PRODUCT	1775 NW CORNELIUS PASS RD	HILLSBORO, OR 97124
TK1163	POLYCAST INC	14140 SW 72ND AVE SUITE 100	TIGARD, OR 97224
TK1943	NEILSEN MANUFACTURING INC	3501 PORTLAND RD NE	SALEM, OR 97303
TK2172	WYLE ELECTRONICS INC	10300 SW NIMBUS AVE BLDG P, SUITE B	PORTLAND, OR 97223
TK2250	ARROW ELECTRONICS INC.	9500 SW NIMBUS AVE, BLDG E	BEAVERTON, OR 97008-7163
TK2376	CONDUCTIVE RUBBER TECH	22125 17TH AVE SE, SUITE 117	BOTHELL, WA 98021
TK2491	RIFOCS CORPORATION	1340 FLYNN RD	CAMARILLO, CA 93012
TK2548	XEROX CORPORATION	14181 SW MILLIKAN WAY	BEAVERTON, OR 97005
TK2563	REVTEK INC	4288 SE INTERNATIONAL WAY	PORTLAND, OR 97222
TK2582	TUFF CAT USA LLC	814 N HAYDEN MEADOWS DRIVE	PORTLAND, OR 97217
TK2601	MAXTEK COMPONENTS CORPORATION	13335 SW TERMAN RD PO BOX 428	BEAVERTON, OR 97075-0428
TK2647	INSTRUMENT SPECIALTIES CO INC.	C/O TEMCO NW 1336 SE 51ST STREET	HILLSBORO, OR 97123
TK6173	MULTI-FINELINE ELECTRONIX INC (MFLEX)	DBA: MFLEX 1301 N DYNAMICS STREET	ANAHEIM, CA 92806

Manufacturers cross index (cont.)

Mfr. code	Manufacturer	Address	City, state, zip code
TK6181	IMC PLASTICS INC	19400 SW TETON AVE	TUALATIN, OR 97062
TK6253	VOLEX INTERCONNECT INC	646 CARRIBEAN DR	SUNNYVALE, CA 94089-1108

Replaceable Parts List

Fig. & index number	Tektronix part number	Serial no. effective	Serial no. discont'd	Qty	Name & description	Mfr. code	Mfr. part number
1-1	016-1441-00			1	POUCH, PLASTIC: POUCH	80009	016-1441-00
-2	211-1050-00			12	SCREW,MACHINE:6-32 X 0.312 L,PNH,STL CAD,T15	0KB01	OBD
-3	355-0298-00			4	STUD.SNAP:0.570 DIA,0.165 THK,STAINLESS STEEL	TK0588	355-0298-00
-4	348-1648-00			4	FOOT:REAR W/CORD WRAP,THERMOPLASTIC	TK6181	348164800
-5	211-0720-00			4	SCR,ASSEM WSHR:6-32 X 0.500,PNH,STL,CDPL,T-15	0KB01	ORDER BY DESCRIPTION
-6	161-0104-00			1	CABLE ASSY,PWR,;3,18 AWG,92 L,SVT, (STANDARD ACCESSORY)	TK2432	ORDER BY DESC
-7	159-0046-00			2	FUSE,CARTRIDGE:3AG,8A,250V,15SEC,CER	71400	ABC 8
	159-0381-00			2	FUSE,CARTRIDGE:5 X 20 MM,6.3A,250V,FAST BLOW,HIGH BREAKING CAPACITY,UL REC,SEMKO,	71400	GDA-6.3
-8	200-2264-00			2	CAP,FUSEHOLDER:3AG FUSES (AMERICAN)	61935	FEK 031 1666
	200-2265-00			2	CAP,FUSEHOLDER:5 X 20MM FUSES (EUROPEAN)	61935	FEK 031.1663
-9	200-4522-00			1	COVER,RIGHT:PCABS,13.645L X 8.250W, BLUE	TK6181	200-4522-00
-10	212-0232-00			2	SCREW,MACHINE:8-32 X 1.125L, PNH,STL,BLACK OXIDE,T-20	0KB01	OBD
-11	367-0477-00			1	HANDLE,CARRYING:POLYPROPYLENE VINYL GRIP	12136	PT 3170
-12	200-4690-00			1	COVER:BOTTOM RIGHT	0J9P9	200-4690-00
-13	200-4689-00			1	COVER ASSEMBLY:BOTTOM,VINYL CLAD AL,W/FEET (ITEMS 13 & 14)	0J9P9	200-4689-00
-14	348-1515-00			1	FEET,CABINET:CABINET FEET,BLACK,GLASS-FIBRE REINFORCED PLASTIC,SET OF 4 FEET, W/SCREWS	76096	63-526
-15	333-4376-00			1	PANEL,FRONT:ACQUISITION I/O PANEL, AL, LEXAN	22670	333-4376-00
-16	200-4653-00			1	COVER,FRONT:PCABS,17.420L X 8.670W X 2.000	TK6181	200-4653-00
-17	101-0151-01			1	TRIM,FRONT:PCABS,17.200W X 8.450H, SILVER GRAY	TK6181	101-0151-01
-18	260-2719-00			1	SWITCH,KEYPAD:ELASTOMERIC,FRONT PANEL,ON/OFF	TK2376	260-2719-00
-19	335-0880-00			1	MARKER,IDENT:LABEL,MKD TDS6404 DIGITAL STORAGE OSCILLOSCOPE	80009	335-0880-00
	335-0559-00				MARKER,IDENT:LABEL,MKD TDS6604 DIGITAL STORAGE OSCILLOSCOPE		
-20	200-4510-01			1	COVER:TOP LEFT	0J9P9	200-4510-01
-21	200-4521-00			1	COVER,LEFT:PCABS,13.654L X 8.250W,BLUE	TK6181	200-4521-00
-22	200-4520-00			1	COVER,TOP:PCABS,17.200L X 13.550W,BLUE	TK6181	200-4520-00

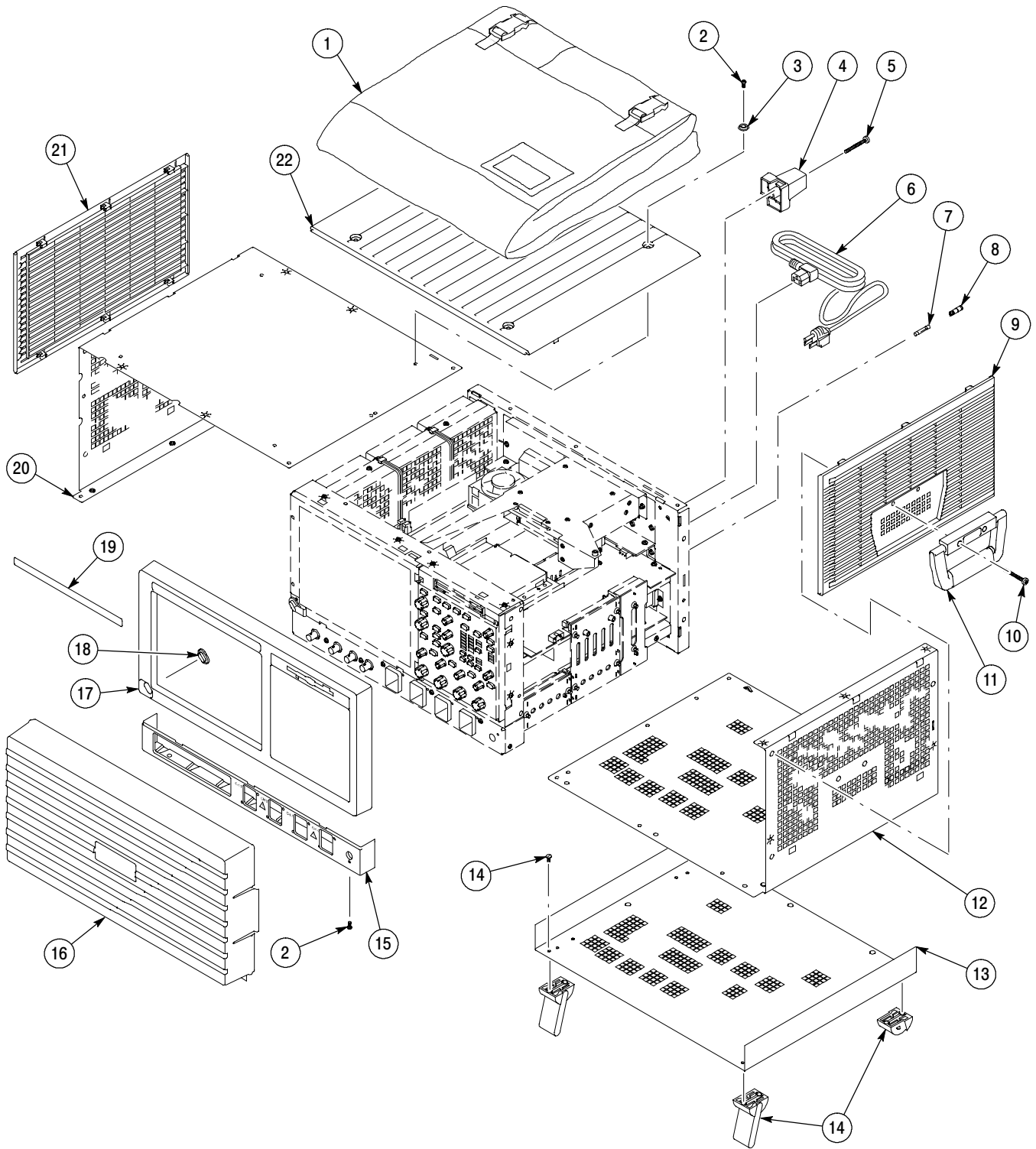

Figure 10-1: External parts

Replaceable Parts List

Fig. & index number	Tektronix part number	Serial no. effective	Serial no. discont'd	Qty	Name & description	Mfr. code	Mfr. part number
2-1	211-1050-00			8	SCREW,MACHINE:6-32 X 0.312 L,PNH,STL CAD,T15	OKB01	OBD
-2	650-4329-00			1	RHDD ASSEMBLY:W/O SW (ITEMS 3 THROUGH 7)	80009	650-4329-00
-3	119-6733-00			1	DISK DRIVE:WINCHESTER,2.5 IN, 20.0GB,SINGLE PLATTER	049S6	119-6733-00
-4	437-0494-00			1	CABINET ASSY:REMOVEABLE HARD DISK DRIVE HOLDER	TK1943	437-0494-00
-5	211-1081-00			4	SCREW,MACHINE:M3 X 0.5 X 3.5MM	OKB01	211-1081-00
-6	174-3925-00			1	CA ASSY,SP:RIBBON,,28 AWG,1.0 L,2 X 22	060D9	174-3925-00
-7	679-4378-00			1	CKT BD SUBASSY:HARD DISK DRIVE INTERFACE	80009	679-4378-00
-8	174-4320-00			2	CA ASSY:FLAT FLEX,26 POS, 9.753L (FLOPPY DRIVE & FRONT PANEL)	060D9	174-4320-00
-9	407-4706-00			1	BRACKET:FLOPPY DRIVE,6.064 X 5.075,ALUMINUM	TK1943	407-4706-00
-10	211-1079-00			2	SCREW,MACHINE:2.6 X 0.45 MM,3.0L,PNH,STL,PHILLIPS	OKB01	10310188-0
-11	119-6106-00			1	DISK DRIVE:FLOPPY,3.5INCH,1.44 MB, 0.5 IN,DDDS	TK2250	FD-05HF5630
-12	679-4840-00			1	CKT BD SUBASSY:PRODUCTION PA BUS	80009	679-4840-00
-13	679-4477-00			1	CKT BD SUBASSY:REAR POWER DISTRIBUTION	80009	679-4477-00
-14	361-1762-00			8	SPACER,SUPPORT:0.250 X 0.171 X 0.375,CKT BD,NYLON	06915	CPST-4-01
-15	679-4476-00			1	CKT BD SUBASSY:FRONT POWER DISTRIBUTION	80009	679-4476-00
-16	614-1006-00			1	PANEL ASSY:FRONT, W/HARDWARE (ITEMS 17 THROUGH 22)	80009	614-1006-00
-17	679-5366-00			1	CKT BD SUBASSY:FRONT PANEL	80009	679-5366-00
-18	260-2760-00			1	SWITCH,KEYPAD:ELASTOMERIC,FRONT PANEL	22670	260-2760-00
-19	366-0821-00			7	KNOB,CAP:W/RED DOT,0.650 D,FR110,SILVER GRAY	22670	366-0821-00
-20	366-0819-00			1	KNOB,EPS:W/RED DOT,PUSH BUTTON,SILVER GRAY	22670	366-0819-00
-21	366-0820-00			7	KNOB,CAP:W/RED DOT,0.425 DIA,TEK SILVER GRAY	22670	366-0820-00
-22	333-4409-00			1	SUBPANEL ASSY:OFF SET	7X318	333-4409-00
-23	650-4186-00			1	MODULE ASSY:TOUCH PANEL (INCLUDES ITEM 24)	80009	650-4186-00
-24	259-0155-01			1	FLEX CIRCUIT:POWER FLEX CIRCUIT SILVER INK	07416	259-0155-01
-25	650-4189-00			1	MODULE ASSY:LCD (INCLUDES ITEMS 26 THROUGH 30)	80009	650-4189-00
-26	343-1676-00			1	CLAMP,CABLE; PC/ABS ALLOY,SILVER GREY	80009	343-1676-00
-27	174-4189-00			1	CABLE ASSEMBLY:FLAT FLEX,DISPLAY ADAPTER	1DM20	174-4189-00
-28	679-5244-00			1	CKT BD :DISPLAY ADAPTER,W/HARDWARE	80009	679-5244-00
	343-1676-00			1	CLAMP,CABLE; PC/ABS ALLOY,SILVER GREY	80009	343-1676-00
-29	174-3618-00			1	CA,ASSY SP:RIBBON,CPR,28 AWG,9.5 L,1X5,0.049CTR	060D9	OBD
-30	119-6260-00			1	POWER SUPPLY:INVERTER BOARD	4T165	104PWBR1
-31	437-0486-01			1	ASSY,FAN:SIX FANS ASSEMBLY	OJ9P9	437-0486-01
-32	174-4188-00			1	CA ASSY:RIBBON (DISPLAY)	060D9	174-4188-00
-33	159-5017-00			1	FUSE:7.0A,125V,FAST BLOW,FUSE IN HOLDER,0.383L X 0.198W X 0.15H,16MM	75915	154 007
-34	679-4379-00			1	CKT BD SUBASSY:CONNECTOR CONVERSION	80009	679-4379-00
-35	174-4321-00			1	CA ASSY:FLAT FLEX,26POS,10.440L (HARD DRIVE)	060D9	174-4321-00

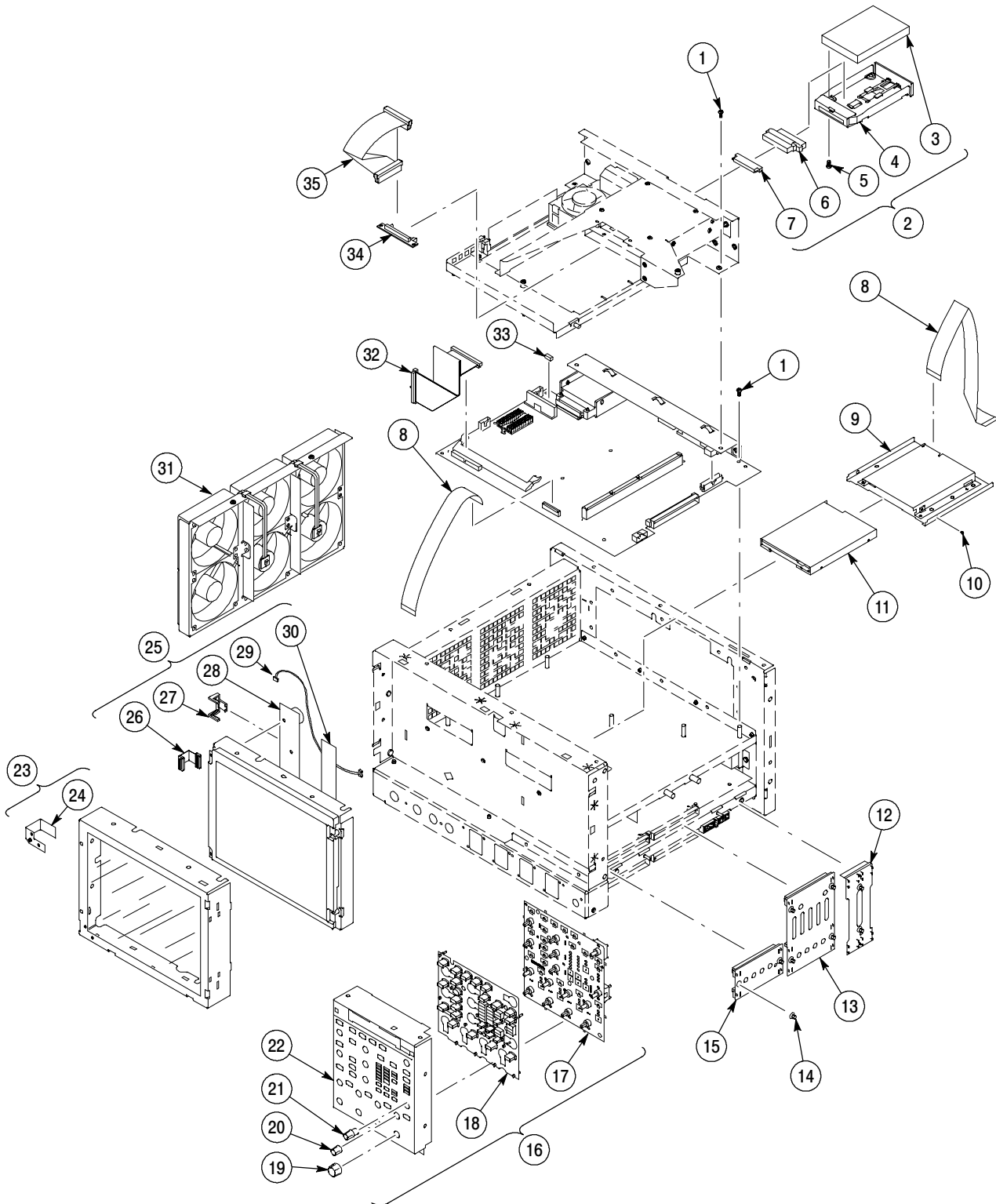

Figure 10-2: Front panel and drives

Replaceable Parts List

Fig. & index number	Tektronix part number	Serial no. effective	Serial no. discont'd	Qty	Name & description	Mfr. code	Mfr. part number
3-1	119-6511-00			1	IC,PROCESSOR:CMOS,MICROPROCESSOR,CELERON, 566 MHZ,66MHZ BUS,SOCKET 370 COMPATIB	34649	BX80526F566128
-2	214-3903-00			8	SCREW,JACK:4-40 X 0.312 LONG,0.188 H HEX HEAD STAND OFF,4-40 INT THD, X 0.312 THD EXT 4-40	05791	LT4276
-3	146-0096-00			1	BATTERY,DRY:3.0V,LITHIUM MANGANESE DIOXIDE,210MAH, 20 X 3.2MM COINCELL,CR2032	61058	CR2032
-4	039-0117-00			1	NLX BOARD: PROCESSOR,RADISYS	80009	039-0117-00
-5	211-1050-00			8	SCREW,MACHINE:6-32 X 0.312 L,PNH,STL CAD PLT,T15	0KB01	OBD
-6	679-4667-00			1	CKT BD SUBASSY:RISER	80009	679-4667-00
-7	211-1050-00			4	SCREW,MACHINE:6-32 X 0.312 L,PNH,STL CAD PLT,T15	0KB01	OBD
-8	213-1061-00			2	JACKSCREW:6-32 X 0.320 EXT THD,M3.5 X 0.6-6 INT THD X 0.215L,GPIB	00779	554043-3
-9	386-7147-00			1	PANEL,I/O:ALUMINUM,POWER PC PROCESSOR	TK1943	386-7147-00
-10	131-6680-00			1	CONN HDR:CARDBUS HDR,SMD,MALE,RTANG,2 X 34	22526	61555-200CA
-11	211-0887-00			4	SCREW,METRIC:M2 X 0.4 X 16 MM L,PH,PHILLIPS DRIVE	0KB01	211-0887-00
-12	671-4659-02			1	CKT BD SUBASSY:PROCESSOR	80009	671-4659-02
-13	441-2271-00			1	CHASSIS:MAIN	OJ9P9	441-2271-00
-14	174-0206-00			2	CABLE ASSY,RF:50 OHM COAX,11.25 L,PELTOLA X PELTOLA	060D9	ORDER BY DESCRIPTION
-15	119-5806-05			1	POWER SUPPLY:CUSTOM,AC-DC,375W,85-275VAC	26003	119-5806-05
-16	210-0046-00			1	WASHER,LOCK:0.261 ID,INTL,0.018 THK,STL CD PL	78189	1214-05-00-0541C
-17	210-0465-00			1	NUT,PLAIN,HEX:0.25-32 X 0.375,BRS CD PL	0KB01	ORDER BY DESCRIPTION
-18	136-0140-00			1	JACK,TIP:BANANA,CHARCOAL GRAY	0KBZ5	N/A
-19	156-9074-00			3	IC,MEMORY:CMOS,SDRAM,32MEG X 64,256MEG,SDRAM, PC100,MT-16LSDT3264AG-10E,DIMM168	S5769	MT-16LSDT3264AG-10E
-20	441-2183-01			1	CHASSIS:REAR DRIVE BAY, AL & STEEL (HDD & CD-RW)	TK1943	441-2183-00
-21	407-4880-00			1	BRACKET,CD-RW:STEEL	TK1943	407-4880-00
-22	174-4231-00			1	CABLE ASSY:CABLE ASSEMBY (CD-RW)	060D9	174-4231-00
-23	671-4377-00			1	CIRCUIT BD ASSY:CD-RW INTERFACE	80009	671-4377-00
-24	119-6691-00			1	DISK DRIVE:OPTICAL,644MEG,CD-RW	50356	19770820-93 (CD-W28E-93)
-25	211-1070-00			4	SCREW:M2 X 2MM,PNH,PHL, STL NI PLT	0KB01	211-1070-00
-26	441-2279-00			1	CHASSIS,NLX:ALUMINUM,W/HARDWARE	TK1943	441-2279-00
-27	211-0720-00			5	SCR,ASSEM WSHR:6-32,0.500,PNH,STL,CDPL,T-15	0KB01	ORDER BY DESCRIPTION

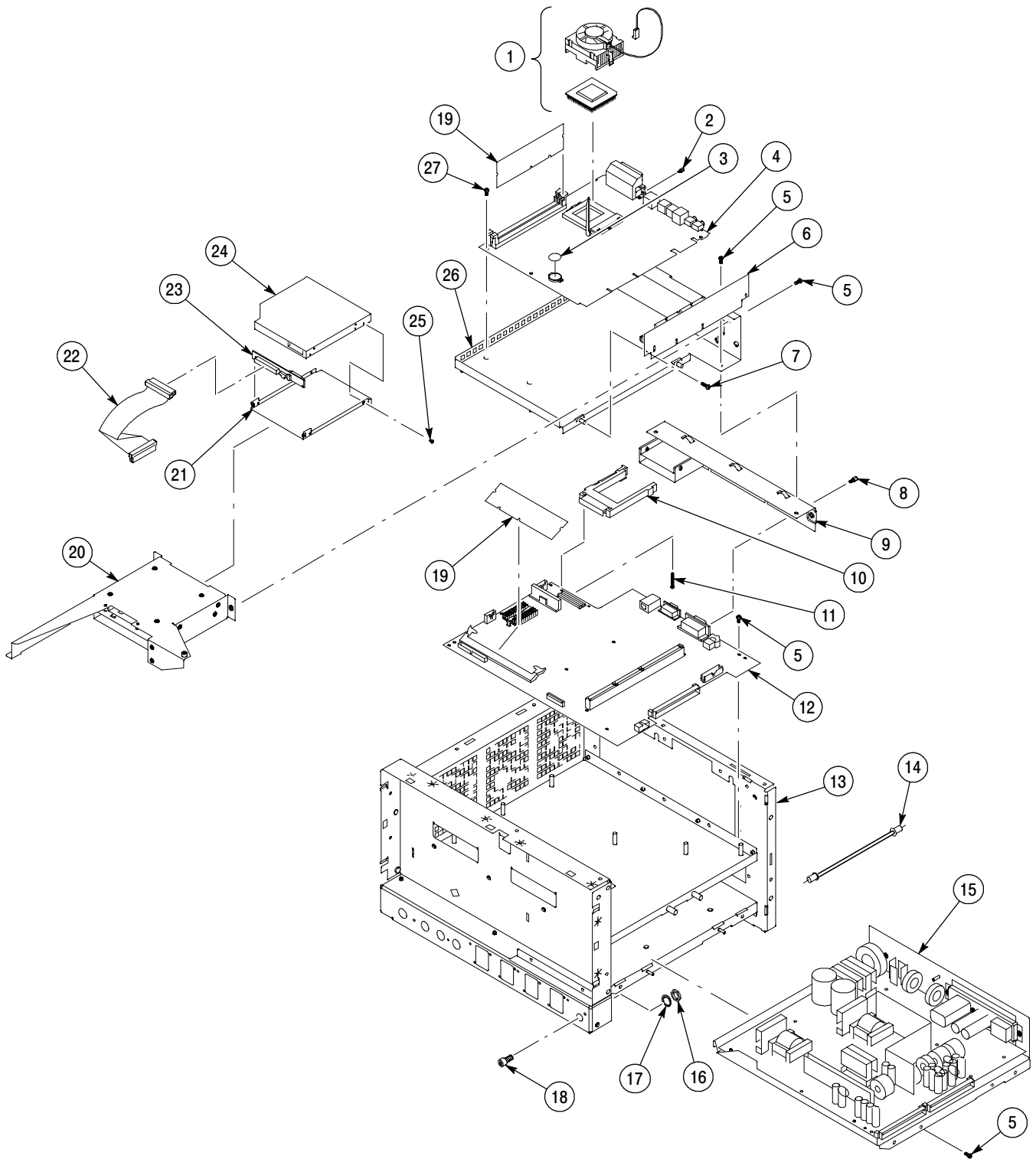

Figure 10-3: Power supply

Replaceable Parts List

Fig. & index number	Tektronix part number	Serial no. effective	Serial no. discont'd	Qty	Name & description	Mfr. code	Mfr. part number
4-1	672-5573-00			1	CIRCUIT BD ASSY: TDS6404 ACQUISITION,BRACKET,RIGID COAX CABLES, 4 GHZ (ITEMS 1 THROUGH 21)	80009	672-5573-00
	672-5276-00			1	CIRCUIT BD ASSY: TDS6604 ACQUISITION,BRACKET,RIGID COAX CABLES, 6 GHZ (ITEMS 1 THROUGH 21)	80009	672-5276-00
-2	174-4502-00			1	CABLE ASSY:RIBBON 24 PIN,POGO TO ACQ BD		174-4502-00
-3	174-0206-00			3	CABLE ASSY,RF:50 OHM COAX,11.25 L,PELTOLA X PELTOLA	060D9	ORDER BY DESCRIPTION
-4	386-7324-00			1	BRACKET:MOUNTING,RELAYS,0.062 AL	TK1943	386-7324-00
-5	174-4566-00			4	CABLE ASSY:COAXIAL,SEMI RIGID COAX CABLE,RELAY,PORT 2,DIAMETER 0.08	060D9	174-4566-00
-6	211-0451-00			16	SCREW,MACHINE:4-40 X 0.750,FLH,CD PL TORX	0KB01	ORDER BY DESCRIPTION
-7	148-0305-01			8	RELAY,ARMATURE:SPDT,PULSE LATCHING,RF COAXIAL,26GHZ,COIL 12VDC,200MA	TK6486	2SE1T11JA REV C
-8	174-2031-00			1	CABLE ASSY:COAX,RFP,50 OHM,6.5L,PELTOLA BOTH ENDS	TK2338	174-2031-00
-9	174-4567-00			4	CABLE ASSY:COAXIAL,SEMI RIGID COAX CABLE,RELAY,PORT 1,DIAMETER 0.086	060D9	174-4567-00
-10	015-1003-00			4	ATTENUATOR,FXD:SMA FEMALE TO SMA MALE,50 OHM,20 DB,2 WATTS,DC-18 GHZ,0.99 L	16179	2082-4573-20
-11	174-4568-00			1	CABLE ASSY:ELEC RELAY CONTROL,8 POSITIONS	060D9	174-4568-00
-12	211-1050-00			12	SCREW,MACHINE:6-32 X 0.312 L,PNH,STL CAD PLT,T15	0KB01	OBD
-13	174-4558-00			1	CA ASSY:COAXIAL,0.086 SEMI RIGID COAX CABLE,RELAY TO HPI,CHANNEL ONE	060D9	174-4558-00
-14	174-4559-00			1	CABLE ASSY:COAXIAL,0.086 SEMI RIGID COAX CABLE,RELAY TO HPI,CHANNEL TWO, LENGTH 10.0	060D9	174-4559-00
-15	174-4560-00			1	CA ASSY:COAXIAL,0.086 SEMI RIGID COAX CABLE,RELAY TO HPI,CHANNEL THREE,APPROX LENGTH 18.	060D9	174-4560-00
-16	174-4561-00			1	CA ASSY:COAXIAL,0.086 SEMI RIGID COAX CABLE,RELAY TO HPI, CHANNEL FOUR,APPROX LENGTH 18.	060D9	174-4561-00
-17	131-1315-01			4	CONN,RF JACK:BNC,PNL,50 OHM,FEMALE,STR,PELTOLA PNL MNT,SILVER ALLOY,0.576 MLG X 0.366 TERMN,	24931	28JR306-1
-18	119-6562-00			1	COMBO ASSEMBLY:BBO SUBASSY,FRONT PANEL (ITEMS 17 THROUGH 22)	80009	119-6562-00
-19	426-2609-00			4	RECEPTACLE:PROBE ASSEMBLY	7X318	426-2609-00
-20	407-4688-00			1	BRACKET:ACQUISITION,4 BMA AND 4 BNC,14.95 X 1.575,AL	TK1943	407-4688-00
-21	211-0722-00			12	SCREW,MACHINE:6-32 X 0.250, PNH, STL, CDPL, T-15	0KB01	211-0722-00
-22	671-5236-00			1	CIRCUIT BD ASSY:PROBE INTERFACE	80009	671-5236-00

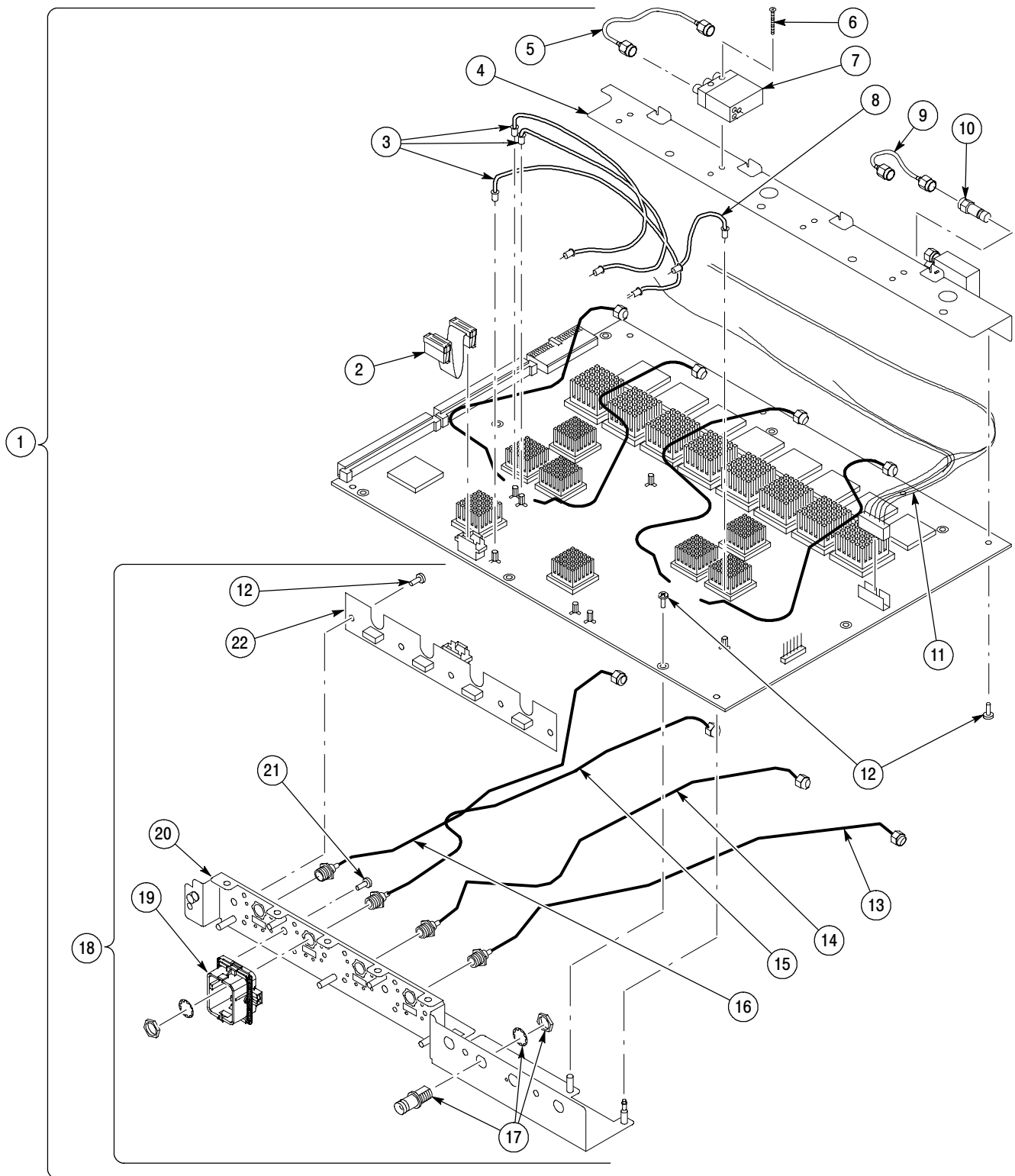

Figure 10-4: Acquisition assembly

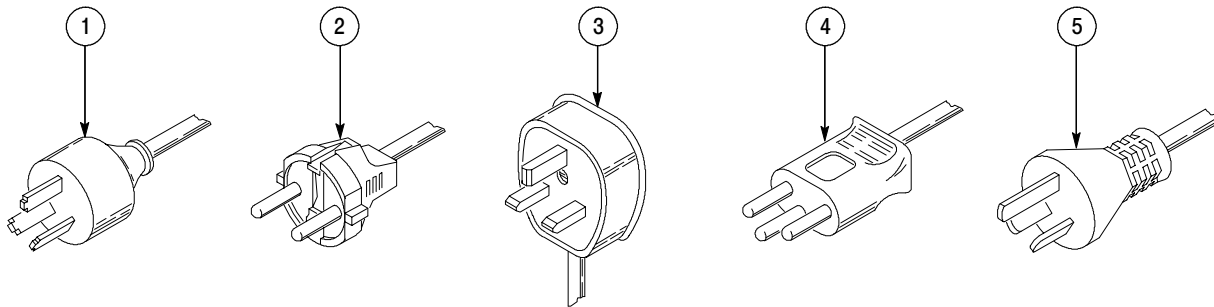

Figure 10-5: Accessories

Replaceable Parts List

Fig. & index number	Tektronix part number	Serial no. effective	Serial no. discont'd	Qty	Name & description	Mfr. code	Mfr. part number
STANDARD ACCESSORIES							
5-1	161-0104-05			1	CA ASSY,PWR:3,1.0MM SQ,250V/10A,2.5 M (OPTION A3 - AUSTRALIAN)	S3109	198-010
-2	161-0104-06			1	CA ASSY,PWR:3,1.0MM SQ,250V/10A,2.5 M (OPTION A1 - EUROPEAN)	S3109	198-010
-3	161-0104-07			1	CA ASSY,PWR:3,1.0MM SQ,240V/10A,2.5 M (OPTION A2 - UNITED KINGDOM)	S3109	209010
-4	161-0167-00			1	CA ASSY,PWR:3,0.75MM SQ,250V/10A,2.5 M (OPTION A5 - SWITZERLAND)	S3109	ORDER BY DESC
-5	161-0306-00			1	CA ASSY,PWR:3,1.0MM SQ,250V/10A,2.5 M (OPTION AC - CHINA)	TK6253	92-2637-250BKH
-----				1	CABLE ASSY,PWER,:3,18 AWG,92 L (STANDARD CABLE - SEE FIG 10-1-6)		
-----				1	POUCH, PLASTIC:POUCH (STANDARD CABLE - SEE FIG 10-1-1)	TK2582	TK1441 BLACK CORDURA
	020-2349-XX			1	SOFTWARE KIT:LICENSE CERTIFICATE EASY RE-STORE,CERTIFICATE AUTHENTICITY,WIN 98 RESTORE CD	80009	020-2349-02
	067-0484-XX			1	DESKEW FIXTURE; WITH INSTRUCTIONS	80009	067-0484-00
	020-2368-00			1	REFERENCE KIT:LANGUAGE MANUALS,TDS7404	80009	020-2368-00
	020-2426-XX			1	REFERENCE KIT:LANGUAGE MANUALS	80009	020-2426-00
	071-0879-00			1	MANUAL,TECH:USER,TDS6604	TK2548	071-0879-00
	071-7012-XX			1	MANUAL,TECH:USER	TK2548	071-7012-00
	071-0880-00			1	MANUAL,TECH:REFERENCE,ENGLISH,TDS6604	TK2548	071-0880-00
	119-6298-00			1	MOUSE:LOGITECCH WHEEL MOUSE	46628	830306-001
-----				4	TEKCONNECT-TO SMA ADPATERS	80009	TCA-SMA
OPTIONAL ACCESSORIES							
	119-6633-00			1	KEYBOARD:USB KEYBOARD CHERRY	01963	G81-3505-LAAUS
	071-0898-00			1	MANUAL,TECH:SERVICE TDS6604	TK2548	071-0898-00

Replaceable Parts List (Cont.)

Fig. & index number	Tektronix part number	Serial no. effective	Serial no. discont'd	Qty	Name & description	Mfr. code	Mfr. part number
	071-7021-00			1	MANUAL,TECH:SERVICE	TK2548	071-7021-00
	016-1790-XX				KIT:RACKMOUNT (OPTION 1R)	80009	016-1790-XX
	118-9402-00				SMALL KEYBOARD, FITS INTO POUCH, PS2 INTERFACE	80009	118-9402-00

